

JANUARY
1920
20 cts.

ELECTRICAL EXPERIMENTER

SCIENCE AND INVENTION

OVER
175
ILLUST.

FIRST
WINGLESS
AIRPLANE

SEE PAGE
868



OVER 125,000 COPIES MONTHLY—LARGEST CIRCULATION OF ANY ELECTRICAL PUBLICATION

The price goes up

Your last chance to procure a complete electrical education at as low a price as \$16, payable \$2 per month.



We had intended to increase the price Nov. 29 last, but the New York printers' strike prevented us from getting out our announcements.

The price of the CROFT LIBRARY OF PRACTICAL ELECTRICITY must go up. We have fought against this increase as long as we could. You have, however, one more chance to purchase at the old price.

In fairness and justness to the readers of this paper, we desire to give everyone notice of the change in price before it goes into effect.

Know electricity as experts know it

No other library or course on the practical side of electricity adheres so closely to actual electrical work as the Croft Library of Practical Electricity. No other set of books or course is more modern, complete, or more easily understood. This Library, with its mine of working details, enables you to master electricity quickly, and to know it as experts do.

The standard in America

Terrell Croft has had twenty years' experience in electrical practice. He started as wireman's helper. Later he became trouble shooter, then draftsman, then electrical engineer for the Westinghouse Co. His twenty years' experience is boiled down to eight flexibly-bound pocket books which are now accepted as the standard in America.

Nothing better at any price

No matter how much you may pay for electrical literature, nor how much you spend on educating yourself in the finer points of practice, you cannot get more reliable, more authoritative, more detailed information than is contained in the Croft Library. It is an innovation in the world of electricity, as a ten-minute examination will prove.

Ten days' free trial NOT ONE CENT IN ADVANCE

In order to receive advantage of the old price on these books, just fill out the coupon and return to us. Keep the books ten days and examine them thoroughly, putting their usefulness to every imaginable test. Then if they are not satisfactory, return at our expense.

Should they come fully up to your expectations, send us \$2 per month for eight months.

McGraw-Hill Book Co., Inc.
239 West 39th Street New York



Meet Terrell Croft

Be guided in your study of electricity by an experienced electrical engineer of high professional standing, a man who gained his knowledge with his sleeves rolled up, and has met your problems in advance. He tells in plain, understandable language how to proceed by the best and most practical methods to the higher position.

FREE EXAMINATION COUPON

After February 28, 1920, price of the set \$20

McGraw-Hill Book Co., Inc.,
239 W. 39th St., New York.

Gentlemen:—Please send me the Library of Practical Electricity (shipping charges prepaid), for 10 days' free examination. If satisfactory I will send \$2 in ten days and \$2 per month until \$16 has been paid. If not wanted, I will write you for return shipping instructions.

Name

Home Address.....

City and State.....

Where Employed.....

Occupation (Ex. 1-20)

Electrical Experimenter

233 FULTON STREET, NEW YORK

Published by Experimenter Publishing Company, Inc. (H. Gernsback, President; S. Gernsback, Treasurer; R. W. DeMott, Sec'y), 233 Fulton Street, New York.

Vol. VII. Whole No. 81

Contents for JANUARY, 1920

No. 9

FIRST WINGLESS AIRPLANE.....	Front Cover	ASTERN! With Engine Running Ahead!.....	885
VERTICAL LIGHTHOUSE BEAMS.....	867	POPULAR ASTRONOMY — THE EINSTEIN THEORY OF RELATIVITY.....	886
THE "HELICOPTER"—A VERTICAL AIRPLANE.....	868	By Isabel M. Lewis, M.A., U. S. Naval Observatory	
By Robert G. Skerrett		THE MOUNT WILSON 100-INCH REFLECTING TELESCOPE—AND HOW BIG TELESCOPES WORK.....	888
IS THE ELECTRIC AIRPLANE POSSIBLE?.....	870	By Professor F. L. Darrow	
WHAT ATOMIC FORCES COULD DO.....	872	THE STRUCTURE OF ELECTRICITY.....	892
ELECTRIC LOCOS CROSS ROCKY MOUNTAINS.....	874	By Dr. Alfred Gradenwitz	
MAGNETIC STORMS.....	876	HOW DOES THE SUBMERGED LADY BREATHE?.....	893
By Professor Lindley Pyle		IS THERE A SUB-ELECTRON?.....	894
SWIMMING POOL PURIFIED BY ELECTRIC RAYS.....	877	By Rogers D. Rush, M.A.	
By Joseph H. Kraus		THE AMATEUR MAGICIAN—THE MAGIC FIRE BOWL.....	896
THE WORLD'S GREATEST THEATER.....	878	By Joseph H. Kraus	
ELIMINATING SMOKE AND DUST ELECTRICALLY—HOW THE SMOKE NUISANCE HAS BEEN ABATED AND MILLIONS OF DOLLARS RECOVERED ANNUALLY FROM ORE-LADEN DUST IN SMELTING WORKS.....	880	PRACTICAL CHEMICAL EXPERIMENTS—INTERIOR HEATING.....	897
ELECTRICAL ENGINEER AT WORK.....	881	By Albert W. Wilsdon	
By H. Winfield Secor		A SMALL RECTIFIER FOR CHARGING STORAGE BATTERIES.....	899
A MODEL "HELICOPTER".....	883	By Elliott A. White	
By William John Beach, M.E.		CALIBRATING ELECTRICAL INSTRUMENTS.....	900
SCIENCE IN LATEST MOVIES.....	884	By Thomas W. Benson	
		ELECTRICAL MACHINIST—No. 3.—REBABBITTING BEARINGS.....	903
		By H. Winfield Secor	



EDITORIAL

A Celestial Short-Circuit



ON November 26th there fell into Lake Michigan a meteor of unprecedented size. Press reports which have since been verified thru a number of independent sources, reveal the following remarkable facts:

Witnesses aver they saw the great ball of fire, white and orange colored, which illuminated the whole country, pass over the lake south of Grand Haven. It fell into the waters, creating a fog of steam clouds.

Telegraph operators of the New York Central lines reported wire trouble as far north as Grand Rapids, Mich.

The power plant of the Calumet Electric Light Co., at Kalamazoo was put out of commission, and another plant near Berrien Springs was disabled.

The greater majority of the meteors which strike the earth are rather small, probably well below 100 lbs., for the individual fragment. Great meteors such as the Peary *Ahnighito*, weighing 37½ tons, are exceedingly rare. The composition of most of the known aërolites is iron with a small percentage of nickel. While the meteor moves thru interstellar space at the terrific speed of from 18 to 36 miles per second, its temperature is that of free space, namely—459° Fahrenheit. The instant the meteor strikes the upper regions of the atmosphere, the latter, acting like a cushion towards the meteor, retards its flight. That means that an immense amount of heat is immediately generated, because you cannot arrest a body traveling at such a prodigious speed without generating heat. But as the aërolite rushes earthward, the atmosphere becomes denser and denser, and the friction between the world wanderer and our planet's air becomes enormous. That means still more heat—sufficient as a matter of fact to melt all or part of the iron-nickel mass.

From the time the meteor enters into our atmosphere till it finally strikes the earth, only a few seconds

elapse. The entire cooling and subsequent heating process ranging from—459° to over 2500° Fahrenheit, probably takes place in less than 3 seconds. When a really big meteor comes along weighing anywhere from 50 tons upward, it can be readily seen that the internal stresses must be enormous, because the core may be at a temperature of—400°, while the shell may be in a molten state. Such a titanic difference in temperatures in a single body sets up ponderous stresses, tending to rend the mass apart, which as a matter of fact happens almost invariably.

In its flight earthward several other things probably occur to a meteor, but as to these we are still ignorant. For one thing, due to the enormous friction set up, the writer advances the thought, that the meteor probably becomes highly electrified, taking on a charge that runs into the millions of volts. Indeed there is no good reason to deny a strong charge even *before* the meteor strikes our atmosphere. Remember a meteor is composed of iron-nickel, a very excellent magnetic alloy. Such a body without a shade of doubt must take on an electrical charge when traversing any field of force, particularly as it travels at such an enormous speed. The old experiment of an unmagnetic iron rod which becomes a magnet when twirled around rapidly by means of a string, is a case in point.

Thus when the big meteor, probably as large or larger than a big mansion, struck Lake Michigan an immense electrical force was liberated—a titanic *short-circuit* it was in fact! The bottom of the lake forming the "ground" or return circuit, it can be readily seen why the electrical disturbances were not only felt for miles around, but were of such a magnitude as to even burn out the big fuses of the electrical power plants.

The effect may be compared to the "return shock" of lightning which often knocks down men and kills cattle, altho they may be at a considerable distance from the spot where the lightning hit.

H. GERNSBACK.

The ELECTRICAL EXPERIMENTER is published on the 15th of each month at 233 Fulton Street, New York. There are 12 numbers per year. Subscription price is \$2.00 a year in U. S. and possessions. Canada and foreign countries, \$2.50 a year. U. S. coin as well as U. S. stamps accepted (no foreign coin or stamps). Single copies, 20 cents each. A sample copy will be sent gratis on request. Checks and money orders should be drawn to order of EXPERIMENTER PUBLISHING CO., INC. If you change your address notify us promptly, in order that copies are not miscarried or lost. A green wrapper indicates expiration. No copies sent after expiration. All communications and contributions to this journal should be addressed to: Editor, ELECTRICAL EXPERIMENTER, 233 Fulton Street, New York. Unaccepted contributions cannot be returned unless full postage has been included. ALL accepted contribu-

tions are paid for on publication. A special rate is paid for novel experiments; good photographs accompanying them are highly desirable.

ELECTRICAL EXPERIMENTER, Monthly. Entered as second-class matter at the New York Post Office under Act of Congress of March 3, 1879. Title registered U. S. Patent Office. Copyright, 1920 by E. P. Co., Inc., New York. The Contents of this magazine are copyrighted and must not be reproduced without giving full credit to the publication.

The ELECTRICAL EXPERIMENTER is for sale at all newsstands in the United States and Canada; also at Brentano's, 37 Avenue de l'Opera, Paris. Sole British agents—Geoffrey Pariser & Greig, 62 and 83 The Mall, Ealing, London. Member of the Audit Bureau of Circulation.

THIS ADVERTISEMENT

Contains a Wonderful Message for

Every Reader of The Electrical Experimenter

The message is of such extraordinary and transcendental importance that no reader of this magazine should fail to answer it. It tells of the discovery of a reign of law, which has eliminated the element of uncertainty and caprice from the lives of men, and substituted law, reason and certitude.

Abundance is a Universal law. The evidence is conclusive. We see it on every hand. Everywhere, Nature is wasteful, lavish, extravagant. Profusion is manifested everywhere. Nowhere is economy observed in any created thing. The millions and millions of trees and plants and flowers and shrubs, the millions of animals, the vast scheme of production and reproduction where the process of creation and recreation is forever going on, all indicate the lavishness with which Nature has made provision for man.

That there is an abundance for all is evident. The storehouse of Nature is inexhaustible. If there appears to be lack anywhere, it is simply an indication that the channels of distribution are as yet imperfect.

Thought is the fuel which fires the imagination, which lights the torch of inspiration, which controls the distribution, which turns the wheel of fortune, from which your future will emerge.

Mind is the Master Key which unlocks the Secret Chamber in which the treasure is stored, and ideas are the seeds from which abundance develops. Perception is the Magic Lamp which lights the way to opportunity, always the invisible precedes and predetermines the nature of the visible.

The Infinity of Wisdom is a knowledge of the mechanism by which we are related to the law of abundance. This knowledge will enable us to consciously control our experiences and environment, compel opportunity and master fate, but we shall soon find that we cannot sow seed of one kind and by "Will" Power make it bear fruit of another. All Natural Laws obey us precisely to the extent that we first obey them. Power is therefore contingent upon a knowledge of the nature and operation of these laws.

The creative Principle is in the Universal, and any attempt to force a compliance with our wishes by the power of the individual Will is doomed to failure, because it antagonizes the very power which it is seeking to use. It is the individual in conflict with the Universal, the finite attempting to coerce the Infinite, it is an inverted conception which cannot succeed.

Water manifests on three planes, as ice, as water and as steam. It is the same compound,

but you would not attempt to drive an engine with ice. Convert it into steam, and it easily takes up the load. It is exactly the same with Mental Ice. Convert it into energy and it becomes a power so volatile, so subtle, so powerful, that it can readily control every other power in existence.

The laws governing in the mental world operate with scientific exactitude, and those who have become familiar with them are enabled to break the bonds of environment, control elementary forces, and utilize the potentialities of Infinity.

The Master Key System is the only clear, concise, comprehensive, definite, exhaustive, distinctive, original and scientific presentation of this wonderful creative power ever formulated by anyone at any time.

A copy of the Master Key will be sent to any address without cost or obligation of any kind.

With this Master Key you will be enabled to ascertain for yourself the underlying cause of every condition which ever has or ever will confront you, and you will be surprised at the astonishing simplicity with which this Wonder Work, this Masterful Idea, this Triumphant Teaching is expounded. There is no charge for the Master Key, it is free!

CHARLES F. HAANEL, 203 Howard Bldg. St. Louis, Mo.

The Master Key is registered in the United States Patent Office, and the Master Key System is copyrighted in every civilized country in the world and all rights are reserved, including the right of translation into all foreign languages.

Read it again. YOU OWE IT TO YOURSELF. Read it again!

LEARN WIRELESS By Mail-In Ten Weeks

Calls Coming in Steadily for National Radio Institute Graduates from All Parts of the Country. Four Concerns Guarantee to Take All Operators We Can Furnish.

Commercial Radio has arrived and many attractive positions are now open in the commercial land radio service, merchant marine, railroads, radio supply factories, lake and ocean steamship lines, telegraph companies and aerial mail service. We are now receiving requests for more National Radio Institute graduates than we can furnish.

Salaries Up to \$350 a Month

with exceptional opportunity for promotion to Radio Mechanics, Electricians, Engineers, and Government Inspectors. No previous experience or training is necessary. You can learn Wireless the National Radio Institute way, in Ten Weeks, by mail, right in your own home. With our help you can quickly qualify for First Grade Government License and a good position paying you approximately \$225 a month to start. Many of our students secure positions before completing the course, because it is based on actual practice and teaches what is needed to make a big success of Wireless work.

Get Your Instructions from the Nation's Capital

(Our Course is Endorsed by the United States Government Officials)

The National Radio Institute, established in 1914, was the first in America to successfully teach wireless by mail. It is headed by authorities who have been closely allied with government training of students. The work is under the direction of J. E. Smith, E. E., formerly director of the Radio Department, Howard University, and E. R. Haas, formerly of the Radio Division of Yale University, assisted by a competent corps of trained instructors and lecturers.

We now have hundreds of students throughout the world. Our location in the Nation's Capital, together with the standing of our officers and their wide acquaintance among government officials connected with Wireless activities, places us in position to give our students the best instructions obtainable and to be of the utmost help in assisting them to secure good paying positions.

Travel If You Want To

If you want to travel and see the world, go to foreign countries and increase your knowledge of world affairs, wireless offers you the chance of a life time. However, you are not obliged to travel, but may secure a permanent position at one of the many land radio offices, railroads, telegraph or steamship companies, if preferred.

Pay As You Learn

Our plans of payment places a wireless education within the reach of anyone who desires to learn.

A small payment down on our convenient payment plan and small following payments enables you to earn the cost of your tuition while actually learning to be a wireless operator.

FREE Instruments to Every Student

In addition to five text books—one hand book—46 special Lessons and 18 Personal Examinations—we send you, while taking our course, a Standard Automatic Transmitting and Receiving Set for sending and receiving messages. These fine instruments are sent only to National Radio Institute Students.

Free Membership in N. R. I. Relay League

Upon enrollment every student in the National Radio Institute is presented with a handsome blue and gold pin, signifying his official membership in the N. R. I. Relay League, with a rapidly growing membership throughout the world.

FREE Course in Radio Telephony

In addition to our complete course in radio telegraphy, every student is given our complete course in modern radio telephony. This course comprises ten special lessons and ten personal examinations. These combined courses enable our students to fill positions requiring thorough knowledge of both radio telegraphy and modern radio telephony.

Send the following coupon today for our FREE book containing all particulars and special offer to students enrolling now.

NATIONAL RADIO INSTITUTE
Dept. 152—14th and U Sts. N. W.
Washington, D. C.

Mail This Coupon Today

NATIONAL RADIO INSTITUTE
Department 152, 14th & U Sts. N. W.,
Washington, D. C.

Send me, free of charge, your booklet, "Wireless The Opportunity of Today", with full particulars regarding your famous ten weeks' Home Study Course and your Special FREE INSTRUMENT OFFER.

Name

Address

City State

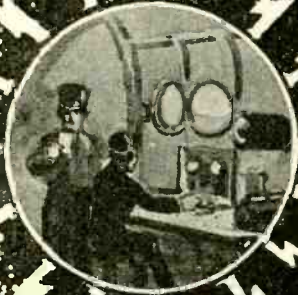

MERCHANT MARINE



LAND COMMERCIAL RADIO

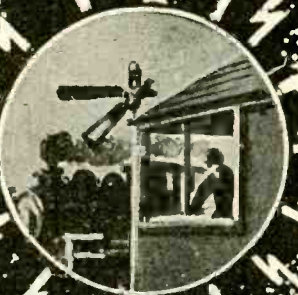

TRAIN DISPATCHING

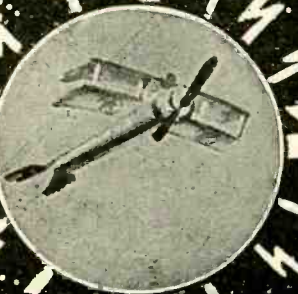

AERIAL MAIL

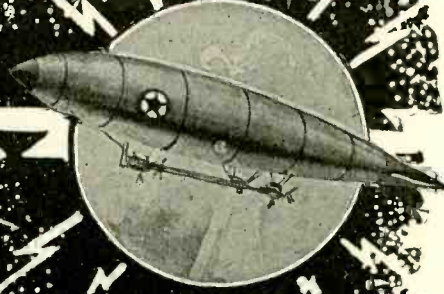

AERIAL COMMERCE

Paragon Shorthand

In 7 Simple Lessons

Can Now Be Purchased for

ONLY \$5.00

YOU know how often you have wished that you could write shorthand. You realized what it meant to busy executives and to business beginners—in efficiency, advancement and increased earning power.

But like thousands of others you dreaded the long, weary months of study, the memory tax, the mental strain, and the high cost, in time and money, of the old systems.

Now you can have your wish. Because, all that you dreaded is done away with in the Paragon Method of Shorthand. The entire system consists of

- The Paragon Alphabet;**
- Twenty-six simple word-signs;**
- Six prefix abbreviations;**
- One general rule for contractions.**

THAT IS ALL. The simple explanations and exercises are divided into seven lessons, each of which you can grasp in one evening. Speed will develop pleasantly as you make daily use of your quickly acquired knowledge.

This is the Paragon System. In 7 evenings you should easily learn it all. See for yourself how perfectly simple it is. Stop right here and study the specimen lesson at the right.

Now you know how easy it will be for you to learn Paragon and how quickly you will be equipped with the great modern instrument of Efficiency.

Thousands of young, ambitious men and women who have failed to learn the old, complicated forms of shorthand have learned Paragon with ease.

They have since become court stenographers, reporters, assistants to business heads and in many cases executives of prominent concerns and institutions. Thousands of grateful letters now in our files attest these facts. Those printed at the left are typical.

Paragon writers are all over the world, in England, Continental Europe, Australia, New Zealand, Canada, South America, Canal Zone, China, Philippine Islands and wherever English is spoken.

Paragon is used in the offices of the largest firms and corporations in the world such as Standard Oil Company, United States Steel Corporation and the great Railway Systems.

You have reached the point where you must know Shorthand to do yourself justice and compete with others—as a busy executive or as a beginner in business.

You know how it is. Two good men apply for a position—one knows shorthand and the other does not—the shorthand man wins every time.

Remember how many of the biggest men in America got their start because they could write shorthand—Frank A. Vanderlip, George B. Cor-

Try This Lesson Now

Take the ordinary longhand letter *d*. Eliminate everything but the long downstroke and there will remain *∟*. This is the Paragon symbol for D. It is always written downward.

From the longhand letter *e* rub out everything except the upper part—the circle—and you will have the Paragon E. *o*

Write this circle at the beginning of *∟* and you will have Ed. *∟*

By letting the circle remain open it will be a hook, and this hook stands for A. Thus *∟* will be Ad. Add another A at the end, thus *∟* and you will have a girl's name, Ada.

From *o* eliminate the initial and final strokes and *o* will remain, which is the Paragon symbol for O.

For the longhand *m*, which is made of 7 strokes, you use this one horizontal stroke *—*

Therefore, *—* would be Me.

Now continue the E across the M, so as to add D—thus *∟* and you will have Med. Now add the large circle for O, and you will have *∟* (medo), which is Meadow, with the silent A and W omitted.

Used in Government Service

"I learned Paragon Shorthand from the home-study course—the lessons alone—without any further aid whatever. At the end of a week I could write the system nicely. I am now using it in the Government service, Treasury Department, Washington, D. C., and am getting along O. K. On account of my efficiency as stenographer, my salary has been increased. I owe my rapid advancement to Paragon Shorthand."—E. C. ALLEY, Room 426, Winder Bldg., Washington, D. C.

In Court Reporting

"I have been the official Court Reporter for the Ninth Judicial District of Louisiana for a number of years, using Paragon Shorthand exclusively. Some years ago I learned this system in seven lessons. With Paragon Shorthand I am able to do any kind of work with as great rapidity as the occasion may demand."—J. MARTIAN HAMLEY, Lake Providence, La.

In Public Schools

"As a result of competitive tests, Paragon Shorthand was unanimously adopted as the exclusive system for the Atlanta High Schools. The classes we have already graduated in Paragon are by far the best we have turned out during my twelve years' connection with the schools."—W. C. LOWE, Head of the Shorthand Departments, 18 Avery Drive, Atlanta, Ga.

Paragon is also being taught in the High Schools of Alton, Ill.; Lafayette, Ind.; Johnstown, Pa., and elsewhere.

In Big Corporations

"I am getting along fine with Paragon Shorthand. It is all you claim for it. It is easy to write, and as for speed—there's no limit."—JOHN WALLER, JR., Standard Oil Company, Sugar Creek, Mo.

IMPORTANT

With reasonable application you will have learned Paragon at the end of a week. If your purpose is to use it for making your own memoranda, you can then begin using it at once. But, if your object be to prepare for a shorthand position, then, at the end of a week you will start speed practice to acquire the necessary speed. Numbers have been able to take positions in a month, two months or three months. It all depends on the time per day devoted to practice. In public schools, on account of many additional studies, the shorthand course is made to last as long as the other courses—one or two years.

PARAGON SHORTHAND INSTITUTE, G-1101 311 Sixth Ave., New York City

Send the complete Paragon Shorthand Course postage prepaid. If not entirely satisfied, I will return it within 7 days after its receipt. If I decide to keep it I will then send you \$5.00 in full payment.

Name.....

Business.....

Address.....

Elect. Exp. 1-20



telyou, William Loeb, Jr., Edward Bok and other men of highest achievement.

Shorthand Writers Wanted

Never before have American business men felt so keenly the shortage of capable shorthand writers. Big business houses are looking everywhere for shorthand writers and are ready to pay any salary within reason to get the service they must have. Salaries are steadily advancing—and yet the demand for shorthand writers has not been supplied.

Speed, Simplicity and Accuracy

are demanded of the shorthand writer by present-day business. With Paragon you can write without mental friction—no complicated rules to remember, no "lines" to watch, no heavy and light "shading", only 26 simple word-signs, no tedious memorizing, no confusing of meanings, through the old elimination of vowels. Paragon notes never get "cold" they are just as easy to read after 10 years as after 10 minutes.

Our records show that in addition to the thousands of young men and women who need shorthand as a help in their business careers, other thousands—business men, professional men, students, clergymen and literary folk—would like to know Paragon Shorthand as a time saving convenience. Still others—fathers and mothers—would like to give their sons and daughters this wonderful advantage in order that they may be able to be self-supporting any time it may be necessary.

Many of these persons who have not a direct need for shorthand but want it as an instrument of efficiency and a daily time saver would buy the complete course of Paragon Shorthand at a popular selling price.

Send No Money

Just fill out and return the coupon and Paragon Shorthand Course will be immediately mailed to you. Try one lesson or all seven, if you like. Keep the Course for seven days—study it and test it from every point of view—then decide whether or not it is worth \$5.00 to you. If you don't want it you have not spent one cent and you are absolutely not under any obligation in returning it. If you decide to keep it send us only \$5, and you will have received, for this small amount, the identical Course taught by Mr. Alexander Lichtentag for 15 years for \$25.

Paragon Shorthand Institute
G1101-311 Sixth Avenue, New York City

NAME

ADDRESS

STATE

ELECTRO IMPORTING COMPANY,
231 Fulton St., New York City.

I enclose herewith 6 cents in stamps or coin for which please send me your latest Cyclopeda Catalog No. 21 containing 176 pages, 263 illustrations and diagrams, including Treatise on Wireless Telegraphy, and 20 coupons for your 160 page Free Wireless Course in 20 lessons.

E. E. 1-20

**FILL IN THIS COUPON FOR
YOUR COPY OF
Our New 176 Page Cyclopeda No. 21
IT IS WAITING FOR YOU**

Full size fac-simile of our catalog just as it looks when you get it
1-2 INCH THICK **WEIGHT ALMOST 1-2 POUND**
263 Illustrations

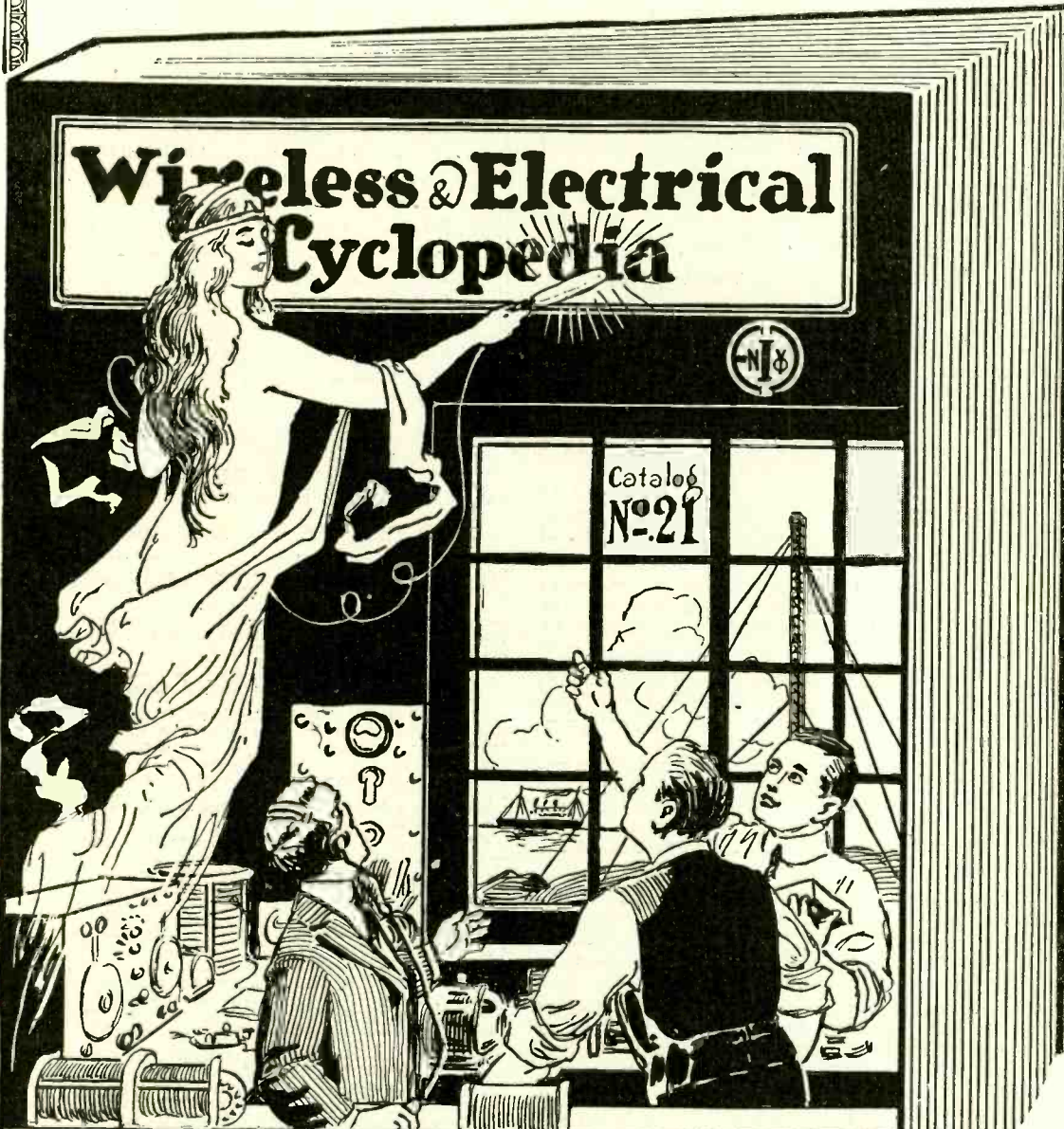

**Wireless & Electrical
Cyclopedia**



Catalog
No. 21

The Electro Importing Co.
231 FULTON STREET
NEW YORK
"EVERYTHING FOR THE EXPERIMENTER"

**A Few Interesting Things from
Catalog No. 21**

Treatise on Wireless Telegraphy by H. Gernsback, Editor Electrical Experimenter and Radio Amateur News—13 big pages, 3 illustrations.

The Wireless Law of 1912—all about it, what you can do and what you can't.

How to receive and send Radio messages.

How far you can send messages.

Table of wave lengths, of principal U. S. & foreign Radio high power stations.

How to receive time signals by Radio.

How to construct an amateur aerial.

How to use the test buzzer.

How to join the "Radio League of America" FREE, including application blank.

How telephone receivers are wound and built, tested and magnetized. 3 pages, 2 illustrations.

Experiments with a pony telephone receiver, with 6 illustrations.

Wireless Codes: Morse, Continental, Navy.

Experiments with spark coils, 3 pages.

How to photograph electrical discharges (sparks).

All about storage batteries, how to test them, recharging, etc.

Tesla experiments, 2 pages.

How to make Selenium Cells (illustrated).

FREE with this wonderful cyclopeda—20 coupons for our 160 page Wireless Course in 20 lessons. 350 illustrations, 30 tables. Catalog explains how you can get this Course absolutely free.

**"THE
LIVEST
CATALOG
IN AMERICA"**

Talkers, High Frequency Apparatus and supplies, Heating Pads, Electro-magnets, X-ray tubes, Telephones, Magnetos, Low Tension Transformers, Books, etc., etc.

**IN A WORD THE MOST COMPLETE
CATALOG IN PRINT**

ELECTRO IMPORTING CO.
231 FULTON STREET NEW YORK, N. Y.

"Everything for the Experimenter"

IN this cyclopeda you will find 116 pages all about radio. One of the greatest catalogs of its kind in print.

You will find in it dozens of wireless instruments of the famous E. I. Co. make. Remember always that this company was the **FIRST** to make and sell wireless instruments, the first wireless outfit having been placed upon the market by them in 1904. The E. I. Co. *knows how*, because it has the experience. Others imitate but cannot equal

E. I. Co. for quality and workmanship.

Other things you will find listed in this catalog: Electrolytic Interrupters, Bulldog Spark Coils, Chemical Outfits, Omnigraphs, Code Practice Sets, Telegraph Instruments, Primary Batteries, Storage Batteries, Solenoids, Hydrometers, Volt and Ammeters, Battery meters, Electrolytic Rectifiers, Rheostats, Tesla Coils, Nickel Plating Outfits, Lighting Plants, Dynamos and Motors, Microphones, Detectiphones, Loud

How One Evening's Study Led to a \$30,000 Job

A Simple Method of Mind Training That Any One Can Follow With Results from the First Day

By a Man Who Made Formerly No More Than a Decent Living

I HOPE you don't think I'm conceited or egotistical in trying to tell others how I suddenly changed from a comparative failure to what my friends term a phenomenal success.

In reality I do not take the credit to myself at all. It was all so simple that I believe any man can accomplish practically the same thing if he learns the secret, which he can do in a single evening. In fact, I know others who have done much better than I by following the same method.

It all came about in a rather odd manner. I had been worrying along in about the same way as the average man, thinking that I was doing my bit for the family by providing them with three square meals a day, when an old chum of mine, Frank Powers, whom I had always thought was about the same kind of a chap as I, suddenly blossomed out with every evidence of great prosperity.

He moved into a fine new house, bought a good car and began living in the style of a man of ample means. Naturally the first thing I did when I noticed these things—for he had said nothing to me about his sudden good fortune—was to congratulate him and ask him what had brought the evident change in his finances.

"Bill," he said, "it's all come so quickly I can hardly account for it myself. But the thing that has made such difference in my life lately began with an article I read a short time ago about training the mind.

"It compared the average person's mind to a leaky pail, losing its contents as it went along, which if carried any distance would arrive at its destination practically empty.

"And it showed that instead of making the pail leak-proof most of us kept filling it up and then losing all we put into it before we

ever reached the place where the contents would be of real use.

"The leak in the pail, the writer demonstrated, was forgetfulness. He showed that when memory fails, experience, the thing we all value most highly, is worthless. He proved to me that a man is only as good as his memory, and whatever progress a man accomplishes can be laid directly to his powers of retaining in his mind the right things—the things that are going to be useful to him as he goes along.

"Farther on in the article I read that the power of the mind is only the sum total of what we remember

—that is, if we read a book and remember nothing that was in it, we have not added one particle to our experience; if we make a mistake and forget about it, we are apt to make the same mistake again, so our experience did not help us. And so on, in everything we do. Our judgment is absolutely dependent on our experience, and our experience is only as great as our power to remember.

"Well, I was convinced. My mind was a 'leaky pail'. I had never been able to remember a man's name thirty seconds after I'd been introduced to him, and as you know, I was always forgetting things that ought to be done. I had recognized it as a fault, but never thought of it as a definite barrier to business success. I started in at once to make my memory efficient, taking up a memory training course which claimed to improve a man's memory in one evening. What you call my good fortune to-day I attribute solely to my exchanging a 'leaky pail' for a mind that retains the things I want to remember."

Powers' story set me thinking. What kind of a memory did I have? It was much the same as that of other people I supposed. I had never worried about my memory one way or another, but it had always seemed to me that I remembered important things pretty well. Certainly it never occurred to me that it was possible or even desirable to improve it, as I assumed that a good memory was a sort of natural gift. Like most of us, when I wanted to remember something particularly I wrote it down on a memorandum pad or in a pocket notebook. Even then I would sometimes forget to look at my reminder. I had been embarrassed—as who has not been?—by being obliged to ask some man whom I had previously met what his name was, after vainly groping through my mind for it, so as to be able to introduce him to others. And I had had my name requested apologetically for the same purpose, so that I knew I was no different than most men in that way.

I began to observe myself more closely in my daily work. The frequency with which I had to refer to records or business papers concerning things that at some previous time had come under my particular notice amazed me. The men around me who were doing about the same work as myself were no different than I in this regard. And this thought gave new significance to the fact that I had been performing practically the same subordinate duties at exactly the same salary for some three years. I couldn't dodge the fact that my mind, as well as most other people's, literally limped along on crutches, because it could not retain names, faces, facts, and figures. Could I expect to progress if even a small proportion of the important things I learned from day to day slipped away from me? The only value of most of my hard-won experience was being canceled—obliterated—by my constantly forgetting things that my experience had taught me.

The whole thing hit me pretty hard. I began to think about the subject from all angles as it affected our business. I realized that probably hundreds of sales had been lost because the salesman forgot some selling point that would have closed the order. Many of our men whom I had heard try to present a new idea or plan had failed to put over their message or to make a good impression

because they had been unable to remember just what they wanted to say. Many decisions involving thousands of dollars had been made unwisely because the man responsible didn't remember all the facts bearing on the situation and thus used poor judgment. I know now that there isn't a day but what the average business man forgets to do from one to a dozen things that would have increased his profits. There are no greater words in the English language descriptive of business inefficiency than the two little words "I forgot."

I had reached my decision. On the recommendation of Powers, I got in touch at once with the Independent Corporation, which shortly before had published the David M. Roth Method of Memory Training. And then came the surprise of my life. In the very first lesson of the course I found the key to a good memory. Within thirty minutes after I had opened the book the secret that I had been in need of all my life was mine. Mr. Roth has boiled down the principles perfecting the memory so that the method can almost be grasped at a glance. And the farther you follow the method the more accurate and reliable your memory becomes. Within an hour I found that I could easily memorize a list of 100 words and call them off backward and forward without a mistake. I was thunderstruck with the ease of it all. Instead of study the whole thing seemed like a fascinating game. I discovered that the art of remembering had been reduced by Mr. Roth to the simplest method imaginable—it required almost nothing but to read the lessons! Every one of those seven simple lessons gave me new powers of memory, and I enjoyed the course so much that I look back on it now as a distinct pleasure.

The rest of my story is not an unusual one among American business men who have realized the value of a reliable trained memory. My income today is close to \$30,000. It will reach that figure at the beginning of our next fiscal year. And two years ago I scarcely made what I now think of as a decent living.

In my progress I have found my improved memory to be priceless. Every experience, every business decision, every important name and face is easily and definitely recorded in my mind, and each remembered experience was of immense value in my rapid strides from one post to another. Of course I can never be thankful enough that I mended that "leaky pail" and discovered the enormous possibilities of a really good memory.

SEND NO MONEY

Mr. Roth's fee for personal instruction to classes limited to fifty members is \$1,000. But in order to secure nation-wide distribution for the Roth Memory Course in a single season the publishers have put the price at only five dollars, a lower figure than any course of its kind has ever been sold before, and it contains the very same material in permanent form as is given in the personal \$1,000 course.

So confident is the Independent Corporation, the publishers of the Roth Memory Course, that once you have an opportunity to see in your own home how easy it is to double, yes triple the powers of your memory, and how easily you can acquire the secret of a good memory in one evening, that they are willing to send the Course on free examination.

Don't send any money. Merely mail the coupon or write a letter and the complete course will be sent, all charges prepaid, at once. If you are not entirely satisfied send it back any time within five days after you receive it and you will owe nothing.

On the other hand, if you are as pleased as are the thousands of other men and women who have used the course, send only \$5 in full payment. You take no risk and you have everything to gain, so mail the coupon now before this remarkable offer is withdrawn.

FREE EXAMINATION COUPON

Independent Corporation

Publishers of The Independent Weekly
Dept. R1101 119 West 40th St., New York

Please send me the Roth Memory Course of seven lessons. I will either remail the Course to you within five days after its receipt or send you \$5 in full payment of the Course.

Name

Address

Elect. Exp.-1-20

David M. Roth

When Mr. Roth first determined to exchange his leaky mind for one that would retain anything he wanted it to, it was because he found his memory to be probably poorer than that of any man he knew. He could not remember a man's name 20 seconds. He forgot so many things that he was convinced he could never succeed until he learned to remember. Today there are over ten thousand people in the United States whom Mr. Roth has met at different times—most of them only once—whom he can instantly name on sight.

Mr. Roth can and has hundreds of times at dinners and lectures asked fifty or sixty men he has never met to tell him their names, businesses and telephone numbers and then after turning his back while they changed seats, has picked each one out by name, told him his telephone number and business connection. These are only a few of the scores of equally "impossible" things that Mr. Roth can do, and yet a few years ago he couldn't remember a man's name twenty seconds. Why go around with a mind like a leaky pail when, as Mr. Roth says, what I have done any one can do."



One Rule That Makes Selling Easy

How I Learned It in A Few Hours and Became a Super-Salesman

YOUNG fellows who take to office work are not usually of the type who are interested in salesmanship. I was no different from the rest; my natural bent, my future, seemed to be on the "inside."

As jobs go I had a fair one. I had the good fortune to be thrown in contact with two unusually high-grade business men. From them I had the chance to learn an interest-

ing business and the opportunity to pile up to my credit a daily record of work well done.

As I look back now I can see that my viewpoint was that of the loyal subordinate who works faithfully, but without a fixed purpose. Like many other young men, I had plenty of hope, which I mistook for ambition.

Purchasing was a vital factor of

our business and I had much to do with the routine end of this work. I naturally became interested in the kind of men who could or could not sell to our firm. The daily contests between buyer and seller were absorbingly interesting to me.

One question which perplexed me, and to which I could not find an answer, was, "What made a first-class salesman? Why were some

salesmen inefficient? Could I be a salesman of any kind—good, fair or poor?" I often wondered. But that was as far as I got. The possibility of actually becoming a super-salesman no more struck me than the possibility of my becoming a beautiful butterfly.

That is, until the night of what I call The Great Revelation, when— But I am getting ahead of my story.

My employers were not easy people to sell. Besides being accomplished buyers they were human beings with likes and dislikes, prejudices and whims. Mr. Pond was rather overbearing and could be very tyrannical. Mr. Booth was our scholar—quiet and cold, oversensitive and refined. Anything crude or noisy grated upon him.

I soon found that all the salesmen who called upon us could be classified into three types: First, and in the large majority, were the incompetents. They generally went away empty-handed. Occasionally, out of pity, Mr. Pond would give one of them a little order. But all men of this type ever got from Mr. Booth was a quick application of high-bred freezing process. He had nothing but contempt for inefficiency.

The second class consisted of the medium-grade salesmen. These men were turned down, however, oftener than they got orders. And I noticed this—that those who could sell to Mr. Pond were often unable to get anywhere with Mr. Booth. It was the other way around, too.

Out of all the salesmen who ever called upon us there were only about five who nearly always made a sale. They seldom went away empty-handed. Nor did they talk much nor work at all hard to make a sale. They made up the third class—the Master Salesmen.

How did they do it? I did not know then. But now I know that consciously or unconsciously they used The One Great Rule of Successful Selling. Even though these five men expressed themselves differently and were entirely different types of men, they all used The One Great Rule. And the men who failed to sell to us did not use this rule.

But let me tell you how I found this out. One day I ran across something in print on salesmanship. I had never taken printed matter on salesmanship at all seriously, but for some reason or other this gripped my attention.

Then came the interest that no novel can give. With the swiftness

of lightning I was well nigh paralyzed with Revelation I possessed the one, the all-embracing, Rule that would make me, bashful clerk that I was, a super-salesman.

Though I may have a thousand future lives to live, I believe that I



**Who Is
Arthur Newcomb?**

After his graduation from college Mr. Arthur Newcomb took up newspaper work, and in the ten years from 1896 to 1906 was reporter, city editor, news editor, managing editor, special correspondent, advertising manager, manager, and advertising counselor for various newspapers and periodicals.

In 1909, he edited the course in "The Science of Business Building" of which fifty thousand copies were sold in the eight years following.

In 1912-13, Mr. Newcomb edited "The Science of Personal Efficiency."

In 1914, in collaboration with Dr. K. M. H. Blackford, he wrote "The Job, The Man, The Boss," which not only had a phenomenal sale, but set in motion the great employment movement which has since been adopted by the United States Chamber of Commerce and the United States Government.

In 1913-14, he edited "Character Analysis by the Observational Method," by Dr. K. M. H. Blackford and, in 1915, collaborated in writing "Analyzing Character," both of which works have had a very wide sale.

In 1918, Mr. Newcomb edited, for Dr. Blackford, the short course, "Reading Character at Sight," now being studied by tens of thousands.

In his Course, "Super-Salesmanship," Mr. Newcomb has broken away from all the old traditional theories of salesmanship and persuasion—which made such a wide appeal and had so much good effect because they were partly true—and has based his work upon human nature as it is and upon the world's greatest commanders, leaders, and salesmen. Mr. Newcomb has been a salesman and salesmanager. He has employed and trained hundreds of salesmen and knows exactly the problem salesmen must solve and how to solve them. In all his experience Mr. Newcomb has found but one great rule for selling goods of any description.

can never forget those wonderful moments when I first read of The One Great Rule of Successful Selling and Its Hundred Devices. It was mighty knowledge to have and use.

To make my story short, I "sold" my firm on the idea of sending me

on the road. Right from the start I sold goods in substantial quantities. In nine short weeks my sales topped the list of our entire selling force. You can well imagine my joy. I had actually out-distanced "Old Timers" and had become the firm's Super-Salesman.

But for what I have done I claim no special ability. I had only a grade-school education, and never was considered anything out of the ordinary intellectually. I say this frankly, as I have no desire to pin roses on myself.

The point I want to make is this: If I, with these handicaps, could so quickly become a top-notch salesman, it is only reasonable to suppose that others can, too. The thing that so quickly made me a Master Salesman was a knowledge of The One Great Rule in Selling and Its Hundred Devices, told by Arthur Newcomb in his astounding 7-Lesson Course in Super-Salesmanship.

Every word of this great course is written out of practical achievement in selling. That is why it stands out from the legion of books and courses on selling.

No preaching, no teaching, no theorizing, no tricks, no stunts. But the one hundred clean-cut, easily-understood devices that will speedily get you under, over, around and through the obstacles to triumphant selling achievement.

You need not take anyone else's word for what the One Great Rule of Selling will do for you. You can be the judge yourself. Send no money. Mail the coupon. This will bring the complete Course to you on five days' approval. Examine it thoroughly; test it out in actual experience. Then if you feel that you can get along without it, send it back and you will owe nothing. But if you want to make it yours, as you surely will, remit only seven dollars in full payment.

As this special free-trial offer may be withdrawn at any time, it is suggested that you take prompt action and mail the coupon now.

INDEPENDENT CORPORATION
Dept. S 1101
119 West 40th Street, New York City

INDEPENDENT CORPORATION,
Dept. S-1101, 119 West 40th Street, New York City.

Please send me Arthur Newcomb's Course in Super-Salesmanship on 5 days' Approval. If pleased with it I will send you \$7 in full payment for it—otherwise I will return the Course.

Name

Address

Elec. Exp. 1-20

MAGAZINE Prices Slashed

Millions

of magazine subscriptions expire this month! With the tremendous advance of paper prices and labor it is certain that nearly all magazines will advance their subscription prices at least from 25% to 50%.

BY ORDERING NOW YOU WILL SAVE BIG MONEY.

In announcing these wonderful prices it is with the absolute knowledge that our readers are offered the lowest prices for standard Magazines that it is possible to obtain anywhere. Only by special arrangement with the publishers are these prices possible, but to take advantage of them, you must act quickly. Don't delay, do it now. This offer is so good that of necessity it must be limited in time. Just think of buying standard Magazines at reduced prices in these times of high prices—just think what you can save on your reading matter for a whole year. Just glance over our wonderful prices, and see how we enable one dollar to bring you two dollars' worth, and then make up your list. When sending your order, don't forget to state where magazines are to be sent. But be sure you do it now. To-morrow means you may forget and lose this wonderful opportunity. All prices quoted are for subscribers in U. S. A. only, Canadian and Foreign subscriptions require additional postage.



The Publishers Will Mail the Magazine Direct From Their Own Office to You.

Electrical Experimenter \$2.00	Our Price	Electrical Experimenter \$2.00	Our Price
Popular Science..... 3.00	\$4.50	Boy's Magazine..... 1.50	\$3.00
Regular Price.....\$5.00		Regular Price.....\$3.50	
Electrical Experimenter \$2.00	Our Price	Electrical Experimenter \$2.00	Our Price
Scientific American..... 5.00	\$8.25	World's Work..... 4.00	\$4.75
Illustrated World..... 2.00		Regular Price.....\$6.00	
Regular Price.....\$9.00			
Electrical Experimenter \$2.00	Our Price	Electrical Experimenter \$2.00	Our Price
Wireless Age..... 2.00	\$4.75	Everybody's Magazine... 2.00	\$4.75
Radio Amateur News.... 1.50		Delineator..... 2.00	
Regular Price.....\$5.50		Regular Price.....\$6.00	
Electrical Experimenter \$2.00	Our Price	Electrical Experimenter \$2.00	Our Price
American Magazine..... 2.00	\$4.75	Designer..... 1.50	\$4.00
Woman's Home Companion..... 2.00		Woman's Magazine..... 1.50	
Regular Price.....\$6.00		Regular Price.....\$5.00	
Electrical Experimenter \$2.00	Our Price		
Etude (for Music Lovers) 2.00	\$3.50		
Regular Price.....\$4.00			

Electrical Experimenter \$2.00	Our Price	Electrical Experimenter \$2.00	Our Price
Harper's Magazine..... 4.00	\$5.25	Electrical Experimenter \$2.00	Our Price
Regular Price.....\$6.00		McCall's Magazine..... 1.00	\$2.50
		Regular Price.....\$3.00	
Electrical Experimenter \$2.00	Our Price	Electrical Experimenter \$2.00	Our Price
Harper's Magazine..... 4.00	\$5.25	Today's Housewife..... 1.00	\$2.50
Regular Price.....\$6.00		Regular Price.....\$3.00	
Electrical Experimenter \$2.00	Our Price	Electrical Experimenter \$2.00	Our Price
Harper's Magazine..... 4.00	\$5.25	McCall's Magazine..... 1.00	\$5.25
Regular Price.....\$6.00		Review of Reviews... 3.00	
Electrical Experimenter \$2.00	Our Price	Electrical Experimenter \$2.00	Our Price
Harper's Magazine..... 4.00	\$5.50	St. Nicholas..... 3.00	\$5.50
Regular Price.....\$6.50		Boy's Magazine..... 1.50	
		Regular Price.....\$5.00	

Electrical Experimenter \$2.00	Our Price	Electrical Experimenter \$2.00	Our Price
Harper's Magazine..... 4.00	\$5.25	Electrical Experimenter \$2.00	Our Price
Regular Price.....\$6.00		Boy's Life..... 2.00	\$3.50
		Regular Price.....\$4.00	
Electrical Experimenter \$2.00	Our Price	Electrical Experimenter \$2.00	Our Price
Harper's Magazine..... 4.00	\$4.50	Illustrated World..... 2.00	\$4.50
Regular Price.....\$5.50		Radio Amateur News.... 1.50	
		Regular Price.....\$5.50	
Electrical Experimenter \$2.00	Our Price	Electrical Experimenter \$2.00	Our Price
Harper's Magazine..... 4.00	\$3.50	Field and Stream..... 2.00	\$3.50
Regular Price.....\$4.00		Regular Price.....\$4.00	

Electrical Experimenter \$2.00	Our Price	Electrical Experimenter \$2.00	Our Price
Harper's Magazine..... 4.00	\$5.25	Electrical Experimenter \$2.00	Our Price
Regular Price.....\$6.00		Illustrated World..... 2.00	\$4.50
		Radio Amateur News.... 1.50	
		Regular Price.....\$5.50	
Electrical Experimenter \$2.00	Our Price	Electrical Experimenter \$2.00	Our Price
Harper's Magazine..... 4.00	\$3.50	Field and Stream..... 2.00	\$3.50
Regular Price.....\$4.00		Regular Price.....\$4.00	

Special Clubbing Prices of Electrical Experimenter WITH:

Club No.	Magazine	Regular Price	With "E. E." Price	Club No.	Magazine	Regular Price	With "E. E." Price
60	Adventure	\$3.00	\$4.75	60	Metropolitan	\$3.00	\$4.75
40	American	2.00	3.75	27	Modern Priscilla	1.50	3.15
50	Asia Magazine	3.00	4.25		Motor	3.00	4.75
35	Boy's Life	2.00	3.75		Motor Boating	2.00	3.75
25	Boy's Magazine	1.50	3.00	40	Munsey's Magazine	3.00	4.75
40	Christian Herald	2.25	4.00	20	McCall's Magazine	1.00	2.75
	Cosmopolitan	2.00	3.75	35	McClure's Magazine	2.00	4.00
	Country Gentleman	1.00	2.75	70	Outing	4.00	5.25
100	Country Life	5.00	6.75	20	Pathfinder	1.00	2.75
40	Current Opinion	3.50	4.75	20	People's Home Journal	1.00	2.75
35	Delineator	2.00	3.50	55	Physical Culture	3.00	4.50
28	Designer	1.50	3.15	40	Pictorial Review	2.00	3.75
35	Everybody's	2.00	3.50	60	Popular Science	3.00	4.50
25	Everyday Engineering	1.50	3.00	25	Radio Amateur News	1.50	3.00
35	Etude (For Music Lovers)	2.00	3.25	50	St. Nicholas	3.00	4.25
35	Field & Stream	2.00	3.50		Saturday Evening Post	2.00	3.75
35	Garden Magazine	3.00	4.75	95	Scientific American	5.00	6.50
	Good Housekeeping	2.00	3.75	60	System	3.00	4.75
80	Harper's Bazar	4.00	5.75	15	Today's Housewife	1.00	2.50
70	Harper's Magazine	4.00	5.75	35	Wireless Age	2.00	3.50
	Hearst's Magazine	2.00	3.75	40	Woman's Home Companion	2.00	3.75
35	Illustrated World	2.00	3.50	17	Woman's Magazine	1.00	2.65
	Ladies Home Journal	1.75	3.50	60	World's Work	4.00	4.75
	Literary Digest	4.00	5.75	50	Youth's Companion	2.50	4.25

For computing together Magazines listed separately, add Class Numbers before title and multiply by 5, giving our price to you in dollars and cents.

Write for Special Prices on ANY Publication not listed here
We will save you money

SEND ALL ORDERS TO "CIRCULATION DEPARTMENT"
EXPERIMENTER PUBLISHING CO., Inc.
233 Fulton Street, New York City, N. Y.



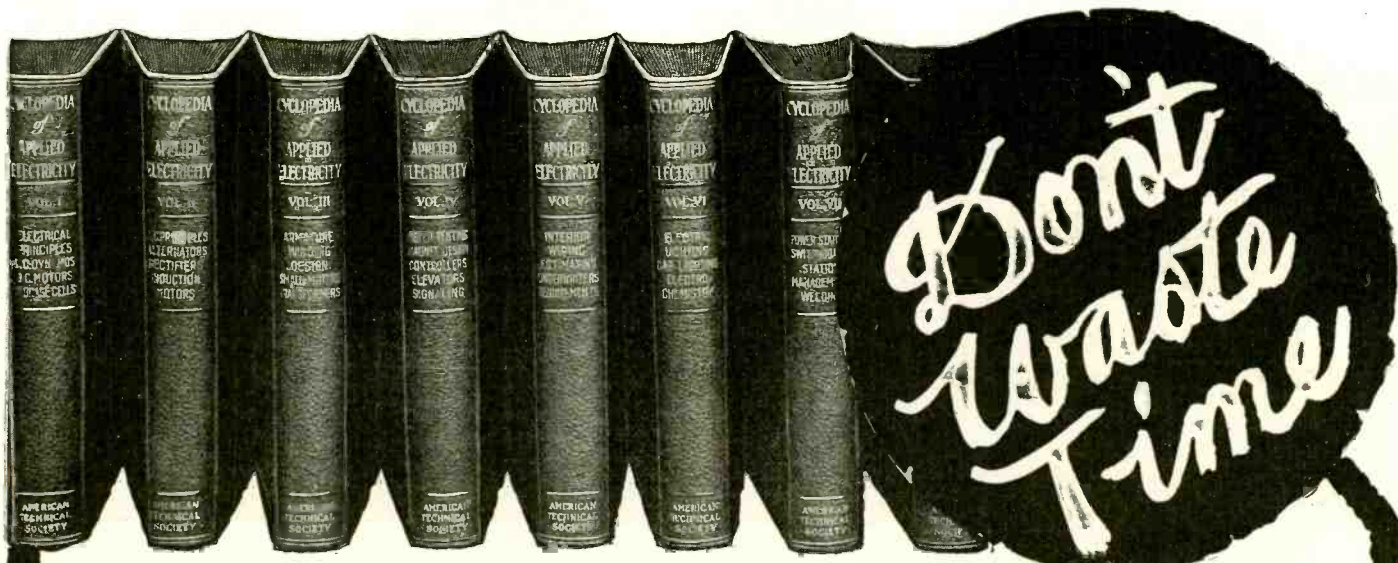

Learn Electricity —the New Way

IT'S no longer necessary to go to school or serve an apprenticeship to learn electricity. With this new library of APPLIED PRACTICAL ELECTRICITY you learn right at home—in your spare time without interfering with your present work.

Any big job that you want in the electrical field is yours if you will train yourself to fill it. It only takes an hour or two a day with these books.

This is the 1920 edition—new from cover to cover—chuck full of the latest methods and most recent discoveries in this fascinating field. Everything is written in plain, good old U. S. language by 27 of the greatest experts in the business. The eight volumes with 3800 pages make up a complete course in electrical engineering. It's a home study course for the beginner and a handy reference guide for the expert combined.

Big Pay for Trained Men Jobs paying \$1500.00 to \$5000.00 a year are waiting for men who can qualify as Electrical Engineers—Substation Operators—Troublemakers—Switchboard Operators—Dynamo Tenders—Electricians. Electricity is the greatest force in the world and it is growing bigger and bigger every day. More and more men are needed all the time. Why don't you get into this big paying field now?

Good Jobs Are Waiting If you are trained in some branch of electricity you will never have to look for a job. The job and the big pay will be looking for you. You can't dodge a good job if you have the "know how" under your hat. Let these 27 great engineers help you to the best kind of job with their books.

Send the coupon below and get them for FREE examination. See our free offer below.

What the Books Teach Elements of Electricity—Electrical Measurements—Electric Wiring—Underwriter's Electrical Requirements—Theory, Calculation, Design and Construction of Direct Current Generators and Motors—Types of Generators and Motors—Management of Electrical Machinery—Electric Lighting—Alternating Current Machinery—Power Transmission—Electric Railways—Self-Propelled Railway Cars—Trackless Trolley—Power Stations—Switchboards and Switching—Storage Batteries—Applied Electro-chemistry—Electric Elevators—Electric Welding and Heating—Wireless Telegraphy and Telephony—Land and Submarine Telegraphy.

Free Service With every set of these great electrical books we give a one year membership in this society. This entitles you to consult our engineers and experts on any electrical problem. Write as often as you like. Ask as many questions as you like for one year.

The World's Greatest Electrical Books LOANED to YOU FREE

We will lend you this wonderful library to use in your own home or shop a whole week FREE. It won't cost you one cent. DON'T SEND ANY MONEY. Just fill out and mail the coupon today and the set of eight volumes will come to you by express collect. You be the judge and find out for yourself what the books will do for you. Use them as you please. Show them to your friends and get their opinion. Then if you have any doubt as to their value send them back at our expense and you won't owe us anything.

Only 7 Cents a Day

If you like the books after a week's examination you pay us only \$2.00 and the same amount each month until \$24.80 is paid. This is only 50 cents a week—7 cents a day. You can't afford to pass up a better job on these easy terms. MAIL THE COUPON NOW.

American Technical Society
Dept. E-251, CHICAGO

**Coupon is
All You
Need—
Send it
Now**



Name.....
Address.....
Reference.....

**American
Technical
Society**
Dept. E-251
Chicago, U. S. A.

Please send me the 8-volume set of Electrical Engineering for 7 days' examination, shipping charges collect. If I decide to buy I will send \$2.00 within 7 days and balance at the rate of \$2.00 a month until \$24.80 has been paid. Then you will send me a receipt showing that the set of books and the Consulting Membership are mine and fully paid for. If I want to get along without the books, I will return them, after 7 days, at your expense.

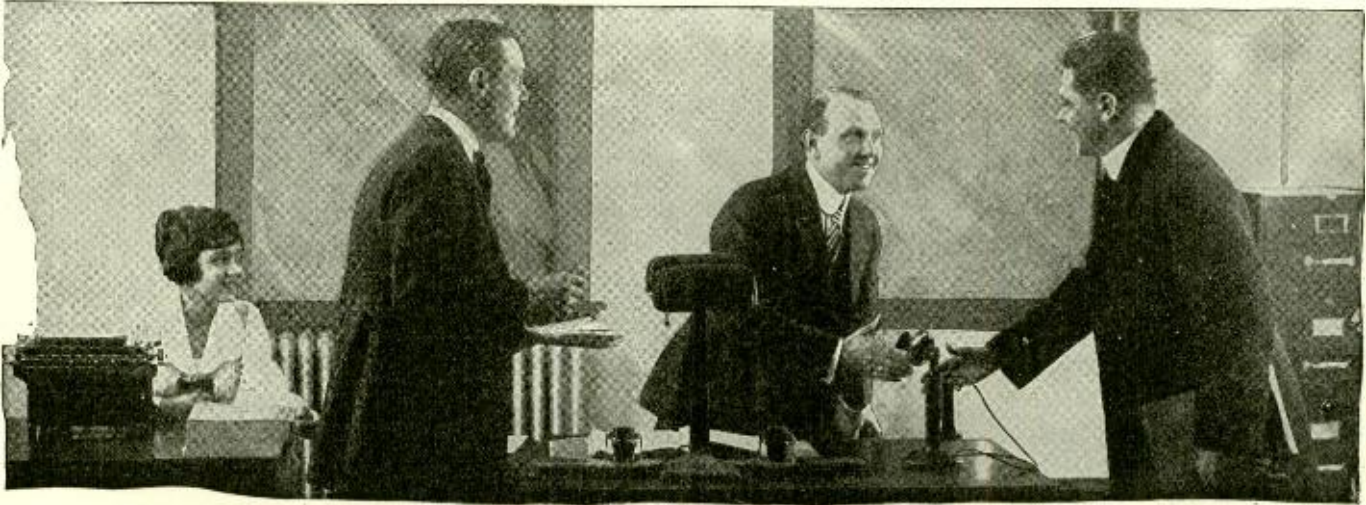

"I was astonished at my new power over men and women. People actually went out of their way to do things for me, they seemed EAGER TO PLEASE ME.

The Secret of Making People Like You

"Getting people to like you is the quick road to success—it's more important than ability," says this man. It surely did wonders for him. How he does it—a simple method which any one can use instantly.

ALL the office was talking about it, and we were wondering which one of us would be the lucky man.

There was an important job to be filled—as Assistant-to-the-President. According to the general run of salaries in the office, this one would easily pay from \$7,000 to \$10,000 a year.

The main requisite, as we understood it, was striking personality and the ability to meet even the biggest men in their offices, their clubs, and their homes on a basis of absolute equality. This the firm considered of even more importance than knowledge of the business.

You know just what happens when news of this sort gets around an office. The boys got to picking the man among themselves. They had the choice all narrowed down to two men—Harrison and myself. That was the way I felt about it, too. Harrison was big enough for the job, and could undoubtedly make a success of it. But, personally, I felt that I had the edge on him in lots of

ways. And I was sure that the firm knew it, too.

Never shall I forget my thrill of pleasure when the president's secretary came into my office with a cheery smile, looked at me meaningly, handed me a bulletin and said, "Mr. Frazer, here is the news about the new Assistant-to-the-President." There seemed to be a new note of added respect in her attitude toward me. I smiled my appreciation as she left my desk.

At last I had come into my own! Never did the sun shine so brightly as on that morning, and never did it seem so good to be alive! These were my thoughts as I gazed out of the window, seeing not the hurrying throngs, but vivid pictures of my new position flashing before me. And then for a further joyous thrill I read the bulletin. It said, "Effective January 1, Mr. Henry J. Peters, of our Cleveland office, will assume the duties of Assistant-to-the-President at the home office."

Peters! Peters—surely it could not be

Peters! Why, this fellow Peters was only a branch-office salesman. . . . Personality! Why, he was only five feet four inches high, and had no more personality than a mouse. Stack him up against a big man and he'd look and act like an office boy. I knew Peters well and there was nothing to him, nothing at all.

January the first came and Peters assumed his new duties. All the boys were openly hostile to him. Naturally, I felt very keenly about it, and did not exactly go out of my way to make things pleasant for him—not exactly!

But our open opposition didn't seem to bother Peters. He went right on with his work and began to make good. Soon I noticed that, despite my feelings against him, I was secretly beginning to admire him. He was winning over the other boys, too. It was not long before we all buried our little hatchets and palled up with Peters.

The funny thing about it was the big hit he made with the people we did business with. I never saw anything like it. They would come in and write in and telephone in to the firm and praise Peters to the skies. They insisted on doing business with him, and gave him orders of a size that made up dizzy to look at. And offers of positions!—why, Peters had almost as many fancy-

figure positions offered to him as a dictionary has words.

What I could not get into my mind was how a little, unassuming, ordinary-to-look-at-chap like Peters could make such an impression with everyone—especially with influential men. He seemed to have an uncanny influence over people. The masterly Peters of today was an altogether different man from the commonplace Peters I had first met years ago. I could not figure it out, nor could the other boys.

One day at luncheon I came right out and asked Peters how he did it. I half expected him to evade. But he didn't. He let me in on the secret. He said he was not afraid to do it as there was always plenty of room at the top.

What Peters told me acted on my mind in exactly the same way as when you stand on a hill and look through binocular glasses at objects in the far distance. Many things I could not see before suddenly leaped into my mind with startling clearness. A new sense of power surged through me. And I felt the urge to put it into action.

Within a month I was getting remarkable results. I had suddenly become popular. Business men of importance who had formerly given me only a passing nod of acquaintance, suddenly showed a desire for my friendship. I was invited into the most select social circles. People—even strangers—actually went out of their way to do things for me. At first I was astounded at my new power over men and women. Not only could I get them to do what I wanted them to do but they actually anticipated my wishes and seemed eager to please me. But let me tell you some of my experiences.

One of our biggest customers had a grievance against the firm. He held off payment of a big bill and switched to one of our competitors. I was sent to see him. He met me liked a cornered tiger. A few words and I calmed him. Inside of fifteen minutes he was showering me with apologies. He gave me a check in full payment, another big order, and promised to continue giving us all his business.

For certain reasons it became necessary for the firm to obtain a signed letter from a prominent public man. Three of our men had tried, and failed. Then I was given the job. I felt I had been made the "goat." But I got the signed letter, and with it an inside tip which enabled us to land a prize order about which our competitors are still guessing and wondering.

Then trouble sprang up at one of our factories. Then men talked strike. Things looked ugly. I was sent to straighten it out. On the eve of a general walkout, I pacified the men and headed off the strike. And not only this, but ever since then this factory has led all our other plants in production.

I could tell you dozens of similar instances, but they all tell the same story—the ability to make people like you, believe what you want them to believe, and to do what you want them to do. I take no personal credit for what I have done. All the credit I give to the

method Peters told me about. We have told it to lots of our friends, and it has enabled them to do just as remarkable things as Peters and I have done.

Which reminds me: One of my wife's close friends moved to another town where she was a stranger. My wife of course knew of my method. She told it

to her friend with the idea that it might be of assistance to her in meeting new people. It helped her so wonderfully that in a very short time she won the close friendship of many of the "best families" in the town. Every one wonders how she did it. But WE know.

But you want to know what method I used to do all these remarkable things. It is this: You know that every one doesn't think alike. What one likes another dislikes. What pleases one offends another. And what offends one pleases another. Well, there is your cue. You can make an instant hit with any one if you say the things they want you to say, and act the way they want you to act. Do this and they will surely like you, and believe in you, and will go miles out of their way to PLEASE YOU.

You can do this easily by knowing certain simple signs. Written on every man, woman and child are signs, as clearly and as distinctly as though they were in letters a foot high, which show you from one quick glance exactly what to say and to do to please them—to get them to believe what you want them to believe—to think as you think—to do exactly what you want them to do.

In knowing these simple signs is the whole secret of getting what you want out of life—of making friends, of business and social advancement. Every great leader uses this method. That is why he IS a leader. Use it yourself and

you will quickly become a leader—nothing can stop you. And you will want to use it for no other reason than to protect yourself against others.

What Peters told me at luncheon that day was this: "Get Dr. Blackford's 'Reading Character at Sight.'" I did so. This is how I learned to do all the remarkable things I have told you about.

You have heard of Dr. Blackford, the Master Character Analyst. Many concerns will not employ a man without first getting Dr. Blackford to pass on him. Concerns such as Westinghouse Electric and Manufacturing Company, Baker-Vawter Company, Scott Paper Company and many others pay Dr. Blackford large annual fees for advice on dealing with human nature.

So great was the demand for these services that Dr. Blackford could not even begin to fill all the engagements. So Dr. Blackford has explained the method in a simple seven-lesson course entitled "Reading Character at Sight." Even a half hour's reading of this remarkable course will give you an insight into human nature and a power over people which will surprise you.

Such confidence have the publishers in Dr. Blackford's course, "Reading Character at Sight," that they will gladly send it to you on approval. Send no money. Merely fill in and mail the coupon. The complete course will go to you instantly, on approval, all charges prepaid. Look it over thoroughly. See if it lives up to the claims made for it. If you do not want to keep it, then return it, and the transaction is closed. And if you decide to keep it—as you surely will—then merely remit Five Dollars in full payment.

Remember, you take no risk, you assume no obligation. The entire course goes to you on approval. You've everything to gain—nothing to lose. So mail the coupon NOW, while this remarkable offer remains open.



"People would come in and write in and telephone in and praise Peters to the skies... he was showered with offers of fancy figure positions."



"In a very short time she won the close friendship of many of the 'best families' in town"

-----FREE EXAMINATION COUPON-----
Independent Corporation
 Publishers of The Independent Weekly
 Dept. B-1101 119 West 40th St., New York
 You may send me Dr. Blackford's Course of seven lessons entitled "Reading Character at Sight." I will either remail the course to you within five days after its receipt, or send you \$5 in full payment of the course.
 Name
 Address

FOR SALE
AT ALL NEWS
STANDS



“THE 100% WIRELESS MAGAZINE”

What “Radio Amateur News” Is:

With its seventh issue RADIO AMATEUR NEWS holds the field undisputedly as the greatest radio magazine in print today. In point of circulation, number of articles, illustrations, RADIO AMATEUR NEWS now leads all other wireless magazines. Take for instance the January issue with its sixty-four pages; there are fifty-five separate purely radio articles and 122 illustrations. *Over thirty-five thousand copies were printed and circulated.*

Each issue of the RADIO AMATEUR NEWS now contains 64 pages (or more) and an artistic cover in two colors. The illustrations average 122 every month and there are from 40 to 50 up-to-date articles, some by our biggest radio scientists, in every issue.

RADIO AMATEUR NEWS is the greatest and biggest radio magazine in print today.

RADIO AMATEUR NEWS is the only INDEPENDENT monthly wireless magazine in existence. It caters to no commercial interests—it has no boss save its readers. It is “different”—it has the latest radio news. It is a scientific magazine but it caters largely to the RADIO AMATEUR—it is by and for the Amateur. It is published by the publishers of the ELECTRICAL EXPERIMENTER, but there is no duplication of articles in the two magazines. Both are entirely different—but both together will give you ALL the radio news of all the world. Whether you are a professor or an Amateur, get a sample copy or order it from your Newsdealer today.

\$100.00 RADIOPHONE PRIZE CONTEST

The future of Radio lies in the Radio telephone, there is no doubt about that. With the Radiophone there is practically no interference; you need learn no code; a radiophone message takes but a fraction of the time of a radiotelegraph message.

The Editor of RADIO AMATEUR NEWS is so enthusiastic about the Radiophone, and he is such a staunch believer in its great future, that he has offered \$100.00 IN GOLD for the best photographs and description of a good amateur Radiophone. Here is your chance for some easy money.

For full particulars see this month's issue of RADIO AMATEUR NEWS.

15c
The Copy
\$1.50
A Year

Canada and Foreign
\$2.00 A Year

SEND
15c FOR
SAMPLE
COPY
TODAY

64 PAGES
122 ILLUSTRATIONS
SPECIAL OFFER

Gentlemen:
Please enter my subscription for RADIO AMATEUR NEWS for the term of one year for which I enclose herewith \$1.50. For this you will send to me also your great Wireless Course containing 160 pages, 350 illustrations, size 6 3/4 x 10" with fine flexible cloth cover. I have added 5c extra for postage. (I have written my name and address in margin below.)

Partial CONTENTS OF JANUARY ISSUE:

- The Priess Loop Set—Part 2
By Walter J. Henry
- How to Build Arc Generators
By Winfield Secor, A.M.I.R.E.
- Static Elimination by Directional Reception
By Dr. Greenleaf W. Pickford
- The Design of Multiple Stage Amplifiers
By Prof. C. L. Fortescue, M.I.E.E.
- Three Electrode Vacuum Tube Trigger Relay
By Prof. W. H. Eccles, D.S.C., M.I.E.E.
- Designing of Amateur Transmitting Antennae
By E. T. Jones
- Rebuilding the Station
By P. F. Geagan
- Clearing Traffic
By “Sparks”
- Junior Radio Course
By W. A. Heppner

EXPERIMENTER PUB. CO., 231 Fulton St., New York City



Talk convincingly and others will instantly get your point of view—think as you do—and carry out your slightest wish.

The Knack of Talking Convincingly

IN nearly every group of men there is one good talker. He is always the leader. Convincing talkers are the dominating leaders of every business. Here's how you can learn the principle of convincing speech in one evening and rise quickly to leadership.

I WONDER if you would have felt as elated as I did. A man whose name you would know instantly—a power in the financial world—had granted me an interview. I wanted him to tell me the secret of his great success. Put yourself in my place if you can, and imagine yourself seated before this multi-millionaire, chatting with him about his boyhood, his start in business and his meteoric rise.

He was the biggest man I had yet interviewed in the hope of getting a real "half-Nelson" on the illusive "secret of success." I had half expected to hear the same old story about "honesty, hard work and stick-to-itiveness." So you can imagine my surprise when he said that his success was due primarily to one thing. To use his own words:

"If you should ask me what advice I would give every young man in business, I would say, 'Learn to talk convincingly.' All success in business is built upon getting others to think and do as you wish—in getting the willing co-operation and loyal support of other men. And the only way this can be had is through becoming a convincing talker."

"There is no ability which will bring success to a man so quickly as the ability to talk convincingly."

And the more men I see who have made their marks in the world, the more I realize that he was right. They are all convincing talkers. With their mastery of words, their ability to talk convincingly, and with the dominating influence of their speech, they have swept away all barriers and have attained success.

IT is no figure of speech, but fact, to say that the great men have talked themselves to success.

Many a man who deserves success is being held back because he can not express his thoughts and ideas in strong, convincing

speech. Many of us deserve a greater salary than we are getting. You may have a wonderful ability—a genius for your work—which is not being rewarded because you can't put your ideas into speech that convinces. Do not let this handicap hold you back another day from the success that is rightfully yours. When the time comes—and opportunity is always at hand—you can be ready to get up and put your thoughts into speech, the sheer force and conviction of which will mark you as a leader.

This knack of talking convincingly will do wonders for any man or woman. Most people are afraid to express their thoughts; they know the humiliation of talking to people and obtaining in answer a casual nod, or a curt "yes" or "no". But when you can talk convincingly, it's different. When you talk, people listen to you.

Can You Do This?
 Can you talk as well in public as at home?
 Can you get financial backing when you want it?
 Can you win confidence, friendship, love through your speech?
 Can you make people listen when you talk?
 Can you hold your hearers spell bound?
 Can you give humorous, extemporaneous talks?
 Can you address any size audience from one to thousands?
 Can you get up and talk, any time, any place, without nervousness?

When you have acquired the knack of talking convincingly, it's easy to get people to do anything you want them to do. You can get special attention from anyone from a hotel clerk up to a millionaire. You can make others see your point of view, think as you do, and carry out your slightest wish.

And again it helps in social life. Interesting and convincing talk is the basis of social success. At social affairs you will always find that a convincing talker is the center of attraction and that people go out of their way to "make up" to him. Talk convincingly and no man—no matter who he is—will ever treat you with cold, unresponsive indifference. Instead, you will instantly "get under his skin." Talk convincingly and any man—even

a stranger—will treat you like an old pal and will literally "take the shirt off his back" to please you.

YOU can get almost anything you want if you know how to talk convincingly enough. You've noticed that in business, ability alone does not always count. Many a man of real ability, who cannot express himself well, is outdistanced by a man of mediocre ability who knows how to talk convincingly. There's no getting away from it, to get ahead—to get

what your ability entitles you to, you've got to know how to talk convincingly.

You have seen or read about scores of courses which claimed to teach convincing speaking. You have often thought you would like to take advantage of them and master this knack of powerful speech. Possibly you have investigated a few of them. But you have always found one of two things. Either the course in question dealt almost entirely with oratory—for which you have no use—or else you discovered that the price was entirely beyond what you wish to pay for such training.

BUT here at last is a wonderful new method of teaching the principles of convincing speech. It is not instruction in oratory or the use of high-sounding words. But it shows you in one evening the principles of talking your way to a better position, more salary and success. And the price—not twenty, thirty or forty dollars—but FIVE.

Not one cent in advance. You examine it free for five days. Then if you want to keep it, send five dollars. If you do not want it, send it back and you are not out a penny. We take all the risk. Send no money. Merely mail the coupon and the complete course goes to you at once.

This course was written by Dr. F. H. Law, for thirty years a lecturer and an authority on speech. When you receive Dr. Law's course, it will be just the same as if you were in personal contact with Dr. Law, getting the benefit of his advice and instruction.

In one evening you will get the secret of talking convincingly. You will learn exactly how to secure complete attention to whatever you are saying; how to make your words forceful and convincing, and make other people do for you the things you want done.

Many men have risen to leadership through the use of Dr. Law's wonderful course, "Mastery of Speech." It may be your "open sesame" to a big success. If you do not want it you cannot lose a cent. Don't send any money in advance. Just mail the coupon. The whole course goes to you at once. Remember what the multi-millionaire said:

"There is no ability which will bring success to a man so quickly as the ability to talk convincingly."

Strike out now with a strong determination for your success. Mail the coupon today.

Free Examination Coupon

INDEPENDENT CORPORATION

Publishers of the Independent Weekly
 Dept. L-1101, 119 West 40th Street, New York

You may send me Dr. Law's course, "Mastery of Speech." I will either remail the entire course to you within five days after its receipt or send you \$5.00 in full payment for the course.

Name

Address

City State

Elect. Exp. 1-20

CHEMISTRY

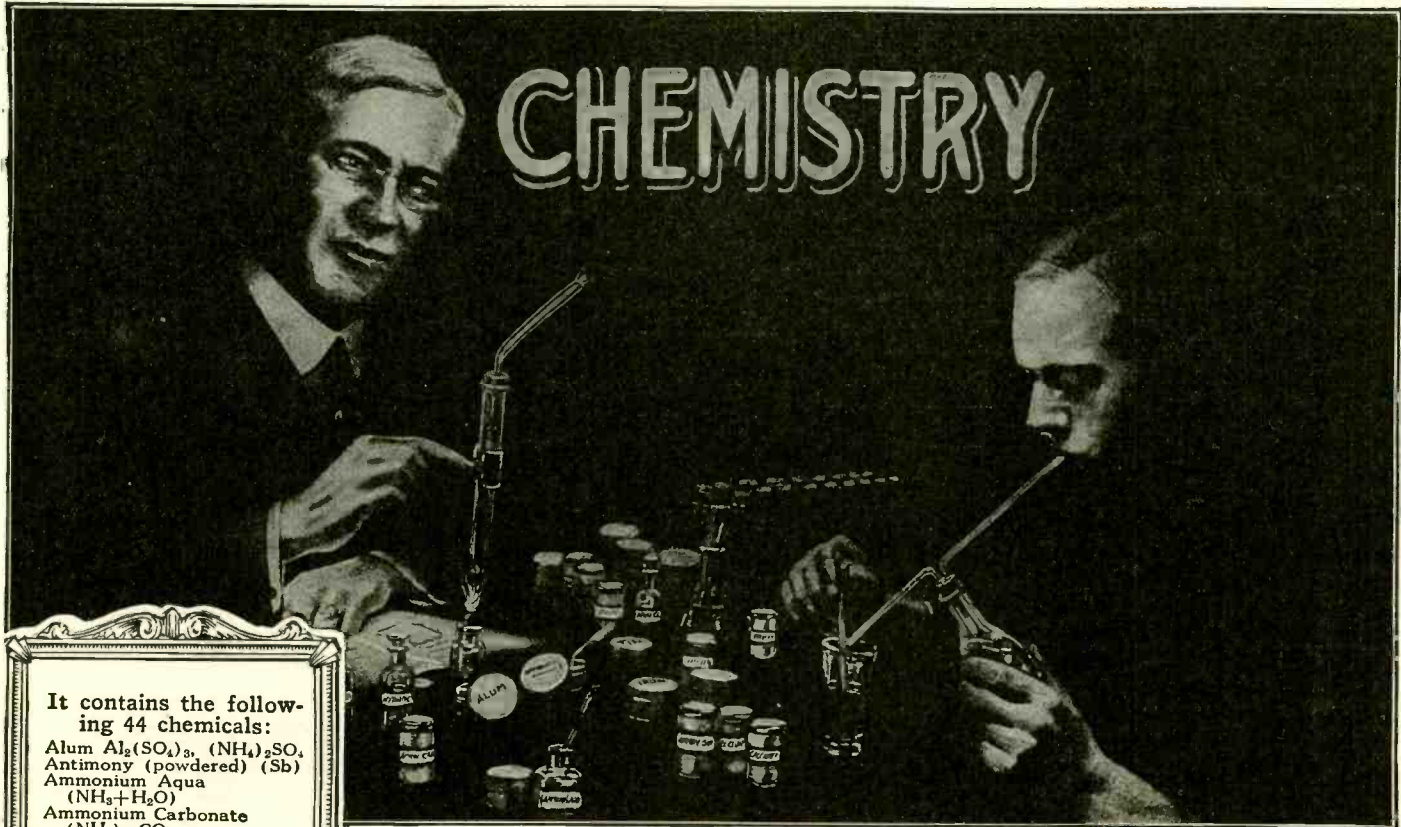

"The Joy of Father and Boy."

Chemical Laboratory

We present herewith to our friends our new E. I. Co. Chemical Laboratory which contains real chemicals and apparatus to perform real chemical experiments. This outfit is not a toy, put up merely to amuse, but a practical laboratory set, with all the chemicals, apparatus and reagents necessary to perform real work and to teach the beginner all the secrets of inorganic chemistry. With this outfit we give free a book containing a Treatise in Elementary Chemistry, useful data and recipes, and 100 instructive and amusing experiments.

DESCRIPTION OF THE OUTFIT:

The outfit consists of forty-four (44) Chemicals all C. P. (chemical pure) put up in appropriate wooden boxes, glass bottles, and hermetically closed jars. The acids are put up in glass bottles, with ground-in glass stoppers and there is a sufficient quantity of chemicals supplied (mostly one to two ounces) enough to make dozens of experiments with each. See list of Chemicals herewith.

The apparatus furnished are all of the best obtainable make and of standard laboratory size and shape. A list of the 17 pieces of apparatus furnished with this outfit is printed also herewith.

The Instruction book is a real Chemistry Course for the Beginner. Some of the Contents are: Division of Matter: This is a Treatise on Elementary Chemistry and deals with the theory of the Elements, Molecules and Atoms, etc. Chemical Nomenclature: This explains in simple language the derivation of the chemical names of the Elements and their compounds. There is a chapter on Laboratory Operations; Glass Working; First Aid; Fire Extinguishers; Experimenters' Aphorisms, etc.

A good part of the book is devoted to Weights and Measures. The Metric System, the English system and the U. S. System are fully explained.

The following tables are furnished: Symbols and Atomic weights of the Elements; Measures of Weights, Volume, Capacity and Length; Per Cent solutions; Conversion of Measure expressed in parts; Poisons and their antidotes; Technical and common name of chemical substances; Formulas for Cleaning various substances, etc., etc.

Among the 100 Experiments are:

How to make chemical tricks; How to make invisible and magic inks; How to test flour; How to test soil; How to Make Chlorine Gas and smoke (German War Gas); How to bleach cloth and flowers. How to produce Oxygen and Hydrogen; How to make chemical colors; How to test Acids and Alkalies and hundreds of interesting hints and formulas.

The price is still \$5.00. Shipping Weight 10 lbs. (Can be shipped by Express only.)

It contains the following 44 chemicals:

- Alum $Al_2(SO_4)_3 \cdot (NH_4)_2SO_4$
- Antimony (powdered) (Sb)
- Ammonium Aqua $(NH_3 + H_2O)$
- Ammonium Carbonate $(NH_4)_2CO_3$
- Ammonium Chloride (NH_4Cl)
- Ammonium Sulphate $(NH_4)_2SO_4$
- Barium Chloride $(BaCl_2)$
- Boric Acid (H_3BO_3)
- Brimstone (Sulphur) (S)
- Calcium Chloride $(CaCl_2)$
- Calcium Oxide (CaO)
- Calcium Sulphate $(CaSO_4 \cdot 2H_2O)$
- Charcoal (Carbon) (C)
- Chloride of Zinc $(ZnCl_2)$
- Copper Sulphate $(CuSO_4)$
- Ferrous Sulphate $(FeSO_4)$
- Ferrous Sulphide (FeS)
- Glycerol (Glycerine) $C_3H_5(OH)_3$
- Hydrochloric Acid (HCl)
- Iodine (I)
- Iron Chloride $(FeCl_2)$
- Iron Oxide (Fe_2O_3)
- Lead Acetate Pb $(C_2H_3O_2)_2$
- Litmus Paper
- Magnesium Carbonate $(MgCO_3)$
- Manganese Dioxide (MnO_2)
- Mercury (Quicksilver) (Hg)
- Nickel Chloride $(NiCl_2)$
- Oxalic Acid $(H_2C_2O_4)$
- Sodium Bicarbonate $(NaHCO_3)$
- Sodium Borate $(NaBO_3)$
- Sodium Carbonate (Na_2CO_3)
- Sodium Chloride (NaCl)
- Sodium Nitrate $(NaNO_3)$
- Sodium Phosphate (Na_2HPO_4)
- Sodium Sulphate (Na_2SO_4)
- Sodium Sulphite (Na_2SO_3)
- Stannous Chloride $(SnCl_2)$
- Sulphate of Nickel $(NiSO_4)$
- Sulphate of Zinc $(ZnSO_4)$
- Sulphuric Acid (H_2SO_4)
- Tin (Granulated) (Sn)
- Zinc (Metal) (Zn)
- Zinc Carbonate $(ZnCO_3)$

The following apparatus are furnished:

- One Standard Washbottle
- One Alcohol Lamp
- One Conical Glass Measure
- One Erlenmeyer Flask
- One Glass Funnel
- One Delivery Tube
- Six Assorted Test-Tubes
- One Test-Tube Holder
- Ten Sheets of Filter Paper
- One Glass Dropper
- One Spoon Measure
- Glass Tubing
- One book containing Treatise on Elementary Chemistry and 100 Chemical Experiments to be performed with this outfit.



THE ELECTRO IMPORTING CO., Mfrs.
231 FULTON STREET NEW YORK CITY



"THE LIVIEST CATALOG IN AMERICA"

Our big, new electrical cyclopedia No. 21 is waiting for you. Positively the most complete Wireless and electrical catalog in print today. 176 Big Pages, 400 illustrations. 300 instruments and apparatus, etc. Big "Treatise on Wireless Telegraphy." 21 FREE coupons for our 160-page FREE Wireless Course in 20 lessons. FREE Cyclopedia No. 21 measures 7x5 1/4". Weight 1/2 lb. Beautiful stiff covers.

ELECTRO IMPORTING COMPANY
231 Fulton St., New York City

I enclose herewith 6 cents in stamps or coin, to cover postage, for which please send me your latest Cyclopedia Catalog No. 21 as described.

NAME

ADDRESS

STATE..... E.E. 1-20

LEARN WIRING

Earn \$50.00 to \$75.00 a Week

This Latest Edition of
"STANDARD WIRING"
Will Make You An Expert Wireman



POCKET SIZE
LEATHER COVER

GENERATORS—How to install them, care for them and operate them; all their troubles and how to prevent and cure them; all diagrams showing connections for compound, series and shunt wound machines. How to operate them in parallel or in series. How to protect them and wire them in accordance with the underwriters' requirements.

MOTORS—How to install them, how to protect and operate them. The required amperes, volts or horse power when any two factors are known. How to take care of hot boxes, sparking commutators and other troubles. How to change the direction of rotation when desired. How to start and stop any kind of motor in any class of service. All diagrams of motor wiring. How to find the proper size of wire for any motor for direct current or for A. C. single, two or three-phase.

OUTSIDE WIRING—Pole line construction, line wires, service wires, roof structures, poles and their dimensions and weights, and how to erect and protect them and wires they carry. Insulators, guard arms, guy anchors. Tree wiring, splicing, service and entrance wiring. How to install Lightning arresters. Transformers with diagrams and instructions.

INSIDE WIRING—When and where to use rubber covered, slow burning and weatherproof wire. How to find the proper size of wire to use for lamps, motors or heating devices for any current, voltage and drop, either by formula or by the many tables that are given in this section of the book. How to wire for two-wire or three-wire systems. Direct current, two-phase and three-phase with formulae and tables, with examples worked out for each system and in a simple manner that anyone can understand and use. How to run wires on walls, ceilings, floors, through partitions and walls and in concealed places, damp places and where dangerous surroundings exist. When and where to install Switches, Cut-outs and Circuit Breakers and just how to do it. How to wire for high and low voltage systems and the precautions to be taken. The proper way to install Knife and Snap Switches, Cabinets and Cut-out Boxes, Outlet, Junction and Switch Boxes, Panel Boards, Wooden and Metal Raceways. How to install complete interior conduit jobs either for rigid metal, flexible metal or flexible non-metallic conduit. Concealed knob and tube work or armored cable. How and where to install and wire electric and combination

lighting fixtures. How and where to use flexible cord and where not to use it. How to install arc lamps and gas filled lamps and the fixtures and rules required.

LIGHT AND ILLUMINATION—What is meant by proper and efficient illumination, the latest data on Mazda and gas filled lamps of every candle power and wattage. Direct, indirect and semi-indirect illumination and where each should be used. Illumination required for various classes of service from show window lighting to public halls and from factories to small residences.

TABLES—Fifty-two tables giving every dimension, carrying capacity, resistance, weight and strength of every size of wire and cable of copper, steel and iron.

All the necessary dimensions, capacities, weights, and other data on conduits, fuses, insulators, lamps, sockets, motor efficiencies, current per horse power of motors.

Electrical units and their equivalents. Proper size of wire for all classes of power, light and heating installations. The proper symbols to use to indicate on plans just what is wanted from a motor to a small snap switch with all necessary diagrams.

APPARATUS AND SUPPLIES—A classified list of the leading manufacturers of officially approved wires and wiring devices. Engines, generators, motors, appliances, fixtures, and all supplies necessary for any complete installation from a Central Station to a small cottage.

The most complete and accurate Book on Wiring and Construction published

350 PAGES - LEATHER COVER - POCKET SIZE, \$1.50

Sent Postpaid to Any Address on Receipt of Price by

H. C. CUSHING, Jr., 8 West 40th St., New York

Every Electrical Inspector in the United States will approve your work if done in accordance with the simple rules given in "Standard Wiring"

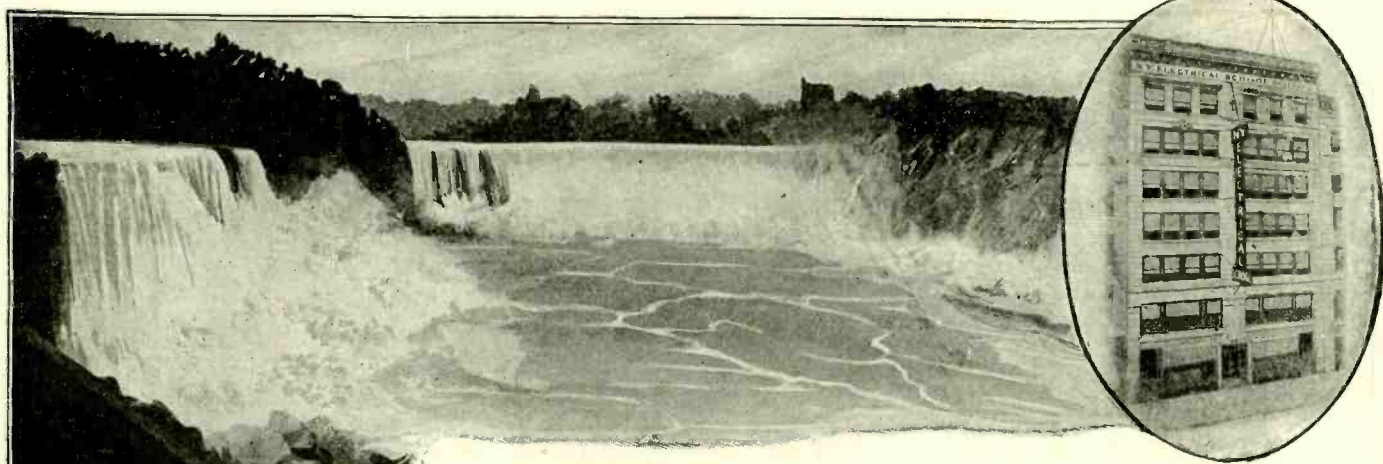

Master Electricity By Actual Practice

The only way you can become an expert is by doing the very work under competent instructors, which you will be called upon to do later on. In other words, *learn by doing*. That is the method of the New York Electrical School.

Five minutes of actual practice properly directed is worth more to a man than years and years of book study. Indeed, Actual Practice is the only training of value, and graduates of New York Electrical School have proved themselves to be the only men that are fully qualified to satisfy EVERY demand of the Electrical Profession.

The Only Institution of the Kind in America

At this "Learn by Doing" School a man acquires the art of Electrical Drafting; the best business method and experience in Electrical Contracting, together with the skill to install, operate and maintain all systems for producing, transmitting and using electricity. A school for Old and Young. Individual instruction.

Over 6,200 Graduates are Successful Men in the Electrical World

No previous knowledge of electricity, mechanics or mathematics is necessary to take this electrical course. You can begin the course now and by steady application prepare yourself in a short time. You will be taught by practical electrical experts with actual apparatus, under actual conditions.

The N. Y. E. S. gives a special Automobile Ignition Course as an advanced training for Auto Mechanics, Garage Men and Car Owners. The course covers completely all Systems of Ignition, Starters, Lighting and other electrical equipment on automobiles, motor boats, airplanes, etc.

Let us explain our complete courses to you in person. If you can't call, send now for 64-page book—it's FREE to you,

New York Electrical School

29 West 17th Street, New York

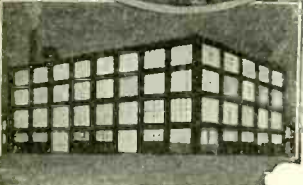
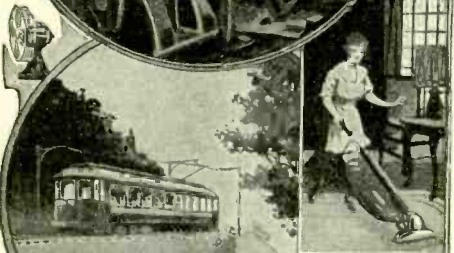
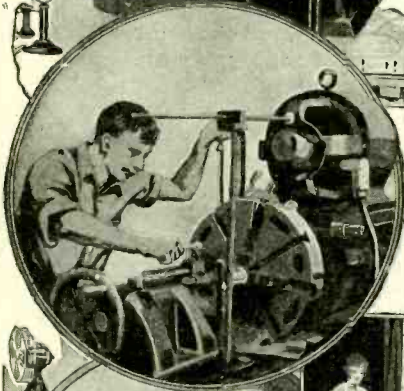
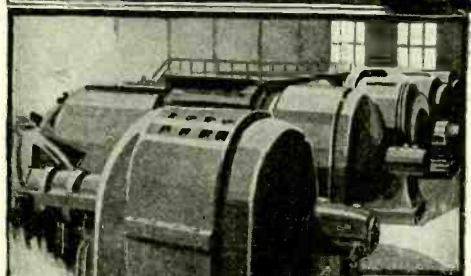

New York Electrical School
29 W. 17th St., New York, N. Y.

Please send FREE and without obligation to me your 64-page book.

..... NAME
 STREET
 CITY STATE



Vol. VII. Whole No. 81

January, 1920

No. 9

Vertical Lighthouse Beams

THE history of lighthouses is as old as navigation itself. Ever since the ancients ventured out of sight of land in their triremes and their sailing craft, there have been mariners' beacons. From the beginning, navigation has been a twenty-four-hour-a-day industry and guiding beacons have been a

projector or searchlight, which can be seen 100 miles at sea. The greatest range heretofore of any lighthouse has been 25 miles.

"It was in the 18th century that the first attempts were made to use an optical system with the light. In 1812, the United States adopted a scheme consisting of a crude copper reflector and a bull's-eye lens

"Within twenty miles of Brooklyn, the most brilliant lighthouse in America shines every night. The Navesink Light at Sandy Hook holds this foremost position, swinging a beam of 11,000,000 candle-power out across the harbor entrance once every ten seconds. It is well worth a trip to this faithful mariners' guide to see the remark-

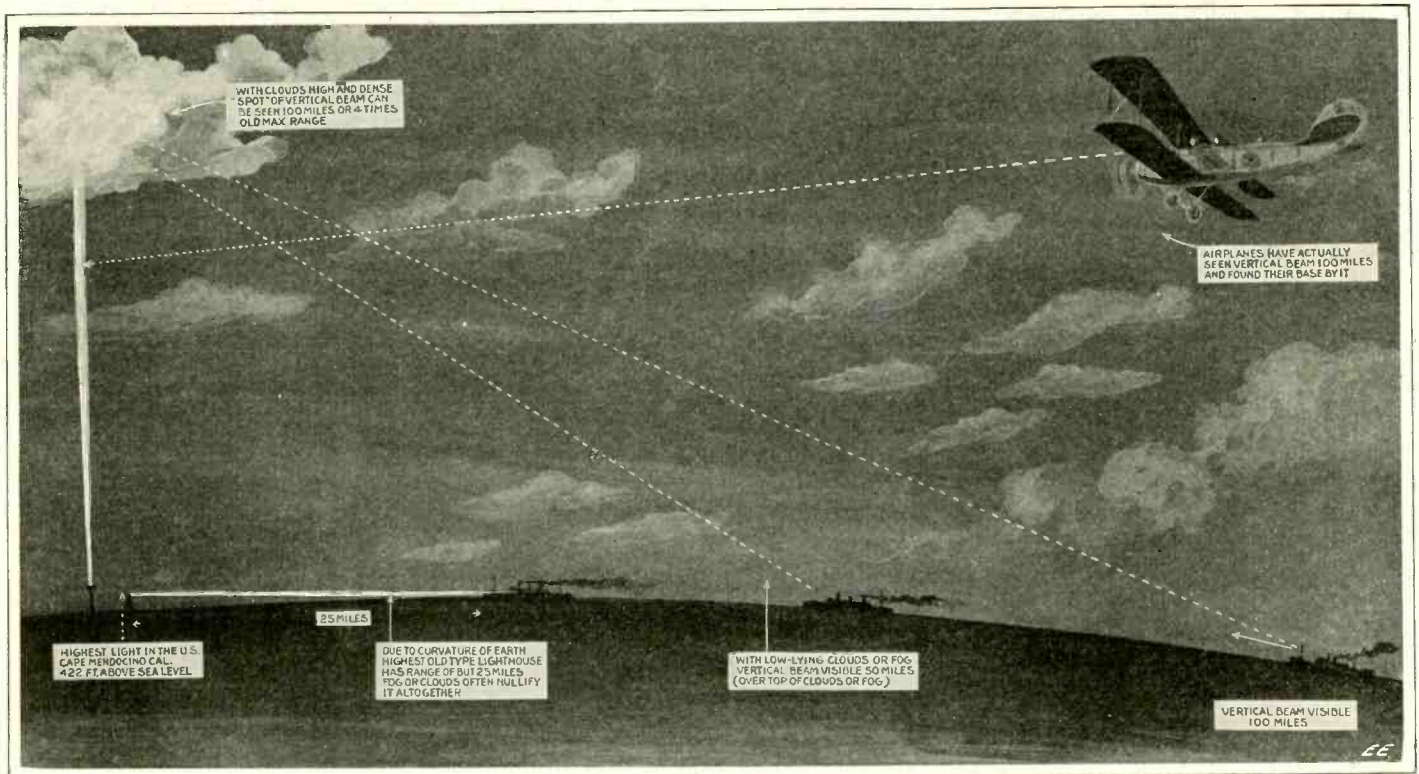

Copyright by E. P. Co., 1920

The Latest Idea in Lighthouses—Vertical Shafts of Light Instead of the Old Horizontal Beams Which Were Often Not Visible at All in Foggy Weather. Vertical Lighthouse Beams Have Been Seen 100 Miles Away—the Maximum Range of the Old Style Beacon Is About 25 Miles.

necessity. Altho vague references to beacon lights are found in literature dating many centuries B. C., the first lighthouse of which we have authentic record is the great Pharos of Alexandria. This famous light of the ancients, which was built about 258 B. C., was a huge tower of solid masonry on which a large bonfire was maintained nightly. Even today one can see, not far from London, the remains of an old masonry beacon quite similar to the Egyptian Pharos." Thus spoke P. R. Bassett, research engineer of the Sperry Gyroscope Company, which concern has recently developed a remarkable vertical lighthouse

in several of the important lighthouses. But, in the terms of one of the old lighthouse reports of the time, it 'made a bad light worse,' and hence was short-lived. It was succeeded, however, by better and better apparatus until in about 1852 the Lighthouse Board adopted the Fresnel system of prisms and lenses, which has remained unimproved for this service up to the present time. This system is now so universally employed for lighthouses that one always thinks of a lighthouse as a tower with one of these beautiful cages of concentric glass rings and prisms mounted in the light-room at the top.

able Fresnel prism head. Two tons of optical glass built in the form of a cylinder about six feet high are mounted so beautifully that one can rotate the system with the slight pressure of a finger. This heavy head floats in a container of mercury and thus rotates with practically no friction. The two-ton head is revolved slowly all night long by the gradual dropping of a small weight through the height of the tower.

"Let us look at the broader aspects of the lighthouse problem and consider the requisites and the limitations. In general,
(Continued on page 928)

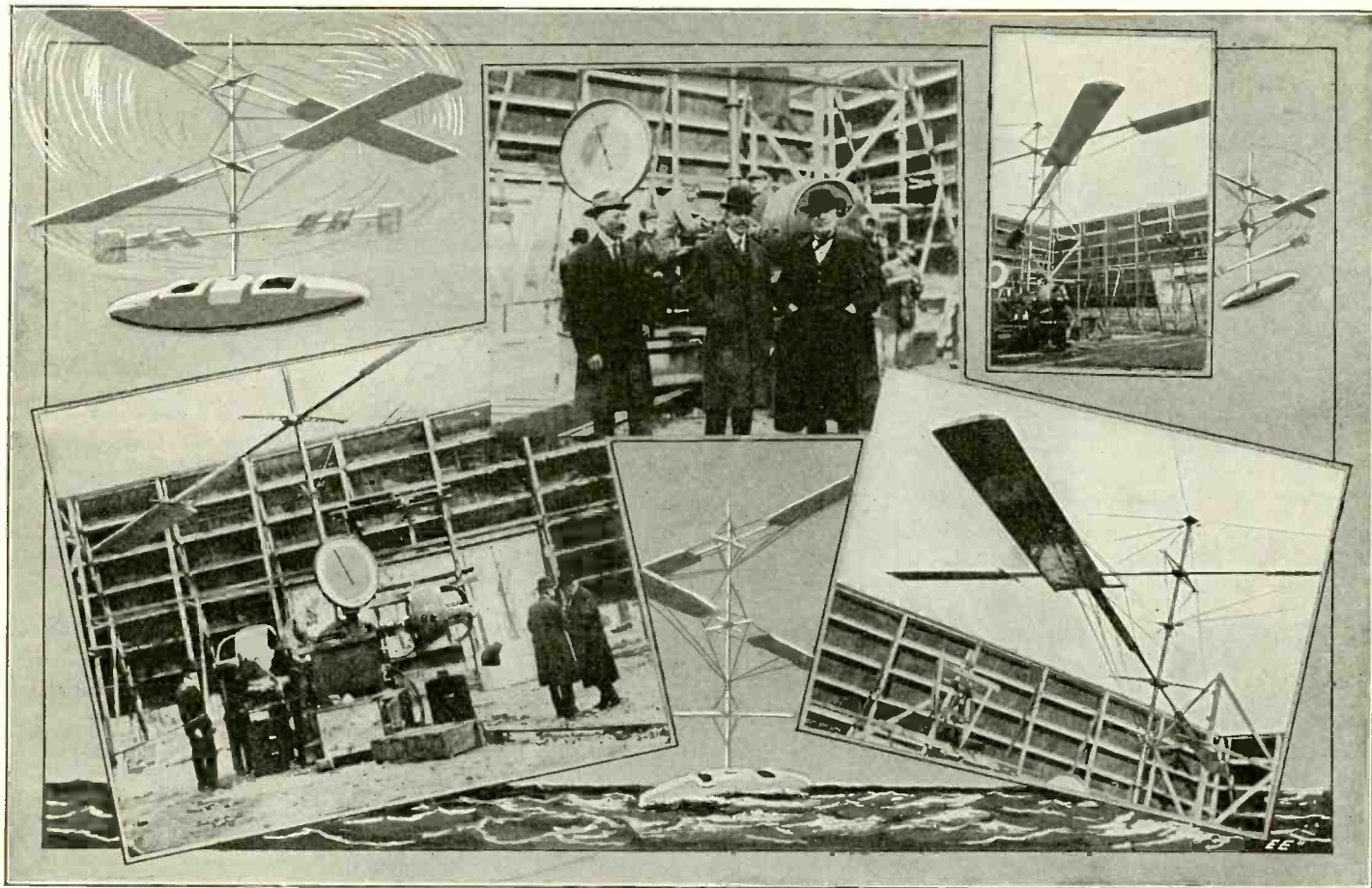

Top Right: Full Length View of Helicopter No. 1, Showing the Testing Installation of the Vital Features of the Machine. Lower Left: Showing the Temporary Installation of Two Electric Motors Each Capable of Developing a Maximum of 100 Horse-power. The Upper Gear Wheel of the Reducing Gear Is Seen Just Above the Box-Like Structure, Which Carries the Large Dial of the Platform Scales Used in Measuring the Lift or Thrust of the Propellers at Different Speeds and Power. The Motor Foundation Was Pivoted So That It Would Show Any Tendency of the Propellers to Turn the Whole Machine About Its Center. This Impulse Was Found to Be Practically Negligible, and the Entire Apparatus When Running at Maximum Trial Speed Could Be Rotated Freely to Right or Left by the Pressure of One's Hand. While Guys Were Attached to the Top of the Shafting to Steady the Machine, This Precaution Was Found Unnecessary, Because the Apparatus Stabilized Itself in a Pronounced Manner, the Faster the Screws Revolved. Lower Right: Details of the Propeller Blades, Guying and Shafting of Helicopter No. 1. Top Center Photo: Dr. Peter Cooper Hewitt in the Center. Thomas A. Edison, Who Is Interested in the "Helicopter," at Dr. Hewitt's Left and One of Dr. Hewitt's Technical Assistants to His Right.

The "Helicopter", A Vertical Airplane

By ROBERT G. SKERRETT

THE HELICOPTER has been an aeronautical puzzle ever since inventive genius tackled the problem of producing a heavier-than-air flying machine. Mechanical success of a sort has been realized from time to time by those variously engaged in this undertaking; but so far as the records show no full-sized craft of this type, with one exception, has been produced capable of lifting its designed full load. In short, they have been unable to rise as they stood. The one exception is the reason for being of the present article.

In an effort to strengthen our coast defense during the recent conflict, Doctor Peter Cooper Hewitt, who has given the world the most economical form of artificial light in his mercury vapor lamp, and Professor Francis Bacon Crocker, long the head of the Department of Electrical Engineering of Columbia University, combined their talents to bring to a practical head certain experiments with the helicopter initiated by Dr. Hewitt in 1906. They began their work in 1917, and a year ago brought their labors to a brilliant climax after they had put *Helicopter No. 1* thru a series of exhaustive tests. The armistice was declared just as the ground trials were finished and *flight* was the next fea-

ture of the program. The cessation of hostilities caused a tremendous slump in aviation, and interest for the nonce in the heli-

copter lagged. Now, however work is about to be resumed, and both Dr. Hewitt and Prof. Crocker are positive in their assertions that the craft will do as well aloft, as it has done within its hangar at Ampere, New Jersey.

The fundamental stumbling block heretofore has been a propeller capable of translating into effective thrust, or *lift*, a sufficient measure of the prime mover's developed power. None of them has in the past given, at useful working speeds, more than 10 pounds of thrust per unit of horse-power—most of the aviation propellers fall considerably below this in performance. The propellers evolved by Dr. Hewitt and Prof. Crocker have yielded more than 20 pounds of thrust per horse-power! These engineers have achieved this by breaking away from the generally accepted types of aeronautical screws both in the matters of size, design, and the materials employed. To be brief, they are adaptations of the aerofoil—the blades are relatively miniature airplane wings.

Without elaborating upon the physical circumstances under which the usual airplane propeller of relatively small diameter functions, it will suffice to mention that it revolves at a speed varying from 1,000 to 2,000 times a minute; it has a very large percentage

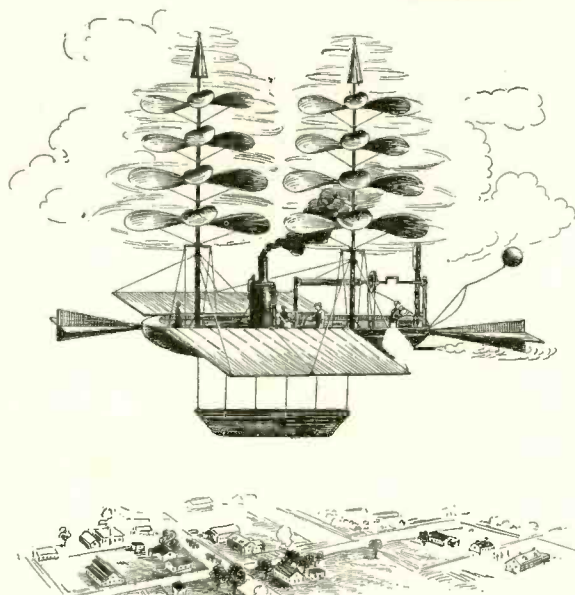

An Early Forerunner of the Helicopter—a Steam Driven Vertical Flier Proposed by Mr. de La Landelle in 1863.

of slip; and its effectiveness is greatly reduced by the way in which it disturbs the air well ahead of it. This latter motion cuts down proportionally the screw's hold upon the atmosphere and its capacity to exert a propulsive effort. As the outer portions of a propeller's blade do most of the helpful work, it is evident that the hub and the massive inner sections of the blades are something of a handicap. Finally, owing to its moderate diameter, the ordinary airplane screw has only a modest volume of air to work upon.

In planning Helicopter No. 1, the first aim was to obtain propeller blades having high sustaining and propulsive factors, as the entire burden of lift and horizontal movement was to depend upon the screws. These were mounted upon concentric, tubular shafts, revolving oppositely. It was not enough to use aerofoil blades; it was quite as necessary to have recourse to propellers of large diameter, driven at comparatively low angular velocities, which would act upon a large mass of air without previously setting up discounting perturbations. To this end, each of the propellers of Helicopter No. 1 has a diameter of 51 feet, and the speed of revolution is about 100 turns a minute.

The blades are attached to tubular steel arms, and placed where the peripheral speed will make most effective their length of 15 feet and their breadth of 2½ feet. The blades consist of a succession of transverse partitions or frames of aluminum over which is laid, top and bottom, a single sheathing of the same metal. To prevent "chattering" the blades are attached to the supporting arms forward of the center of pressure. Therefore, the blades are, in effect, drawn instead of being pushed thru the air. This arrangement gives the blades a certain measure of automatic adjustment of pitch when meeting with varying stresses and changing angles of travel on the part of the machine.

The vital features of Helicopter No. 1, as assembled for testing, weighed something less than 2,300 pounds. When the screws were turned at the rate of 70 revolutions a minute—their two electric motors then developing 126.5 horsepower—the total effective lift amounted to 2,550 pounds, i. e., 20.2 pounds of lift per horse-power! Electric motors were used in place of aviation engines because they made it possible to carry on the tests progressively, from the lowest speeds upward, and to read off at the electric meters the actual power consumed at any moment. The driving apparatus between the motors and the shafts consists of an ingenious reducing gear by which it is feasible to step down the prime movers' speed from 1,400 to 100 revolutions a minute. This makes it practicable to employ the high-speed aviation engine and yet to obtain the desired low rotary movement of the propellers.

The reducing gear was developed by Dr. Hewitt, and, while possessing a measure of flexibility to meet the variable stresses of mechanical flight, is, nevertheless, positive in the contacts between the pinions of the engine shafts and the two geared wheels to which the upper and the lower tubular propeller shafts are, respectively, secured. Revolving oppositely, the propellers exert a very notable stabilizing moment; and so marked is this effect that it was unnecessary to steady the machine by guys during the ground trials!

Furthermore, due to the fact that the screws neutralize one another, so far as they might tend to turn the engine platform about its center, it is at once evident that the helicopter will not spin about its own axis when aloft. Also, it will, for this reason, be easily steered by the rudders to be provided for that purpose. Dr. Hewitt has designed a double reducing gear which will operate at a ratio of 23 to 1. By means of the wide use of opposing forces, and the employment of anti-frictional bearings, this engineer-scientist obtains a series of dynamic couples which neutralize one another and thus insure balanced action.

In all of its essentials, Helicopter No. 1 is a practical man-carrying machine, and can be made ready for flight by substituting two airplane engines in place of the testing

ter has assumed the desired angle, a double set of vertical rudders, opposed to the line of advance, act against one another and hold the machine in that plane of motion. The helicopter will be able to hover aloft, and can be made to ascend or descend vertically with the utmost deliberateness. With half of the engine power "dead" the helicopter will return to earth at a safe speed. However, because of its high ratio of thrust per unit of power, it is feasible to equip an aircraft of this kind with a reserve motor which can be put in gear at the will of the pilot or automatically upon the failure of any of the working engines.

Professor Crocker has thus summarized the advantages of the present type of flying machine: "The helicopter will start from any moderate space such as a roof or ordinary street, and come back to land on the same spot. It is inherently stable and cannot dive, the support being all above and the weight below; so that special skill is not required to operate it at high or low speeds to prevent it from getting out of control. The helicopter is substantially fireproof, being constructed thru-out of metal. To build it, no labor or materials that are difficult to obtain are needed. The craft can be constructed in an ordinary machine shop, and can be assembled, disassembled, or repaired with the skill and facilities commercially available. The helicopter is far less noisy than the airplane and, because of its general design and arrangement, less conspicuous when up in the sky."

As the editors see it this remarkable development in flying machines certainly looks like a long step in advance, if all of the many predicted qualities inherent in its design are fulfilled in actual flight. Especially in war-time will the marked advantages of this type of aircraft be apparent, for its visibility will be far less than that of the present airplane, which has wings of considerable area. Besides, the small wings or revolving screws of the Helicopter will prove a difficult target for the enemy gunners, whether aloft or on land. The cab of the Helicopter can be armored so as to readily withstand ordinary bullets and shell fragments. And just imagine the great superiority of an aerial observing station that can "hover" about, in one spot if need be, in order to gain an accurate sight on enemy artillery and other activities.

We have now considered some of the advantages of the Helicopter, but it would seem to the editors that there are also some disadvantages. For instance, owing to the small sustaining surface of the screws, which act virtually as wings also, what will happen if accidentally or in battle, the engines happen to fail? It would seem that the airship would obey the law of gravity and dart earthward at a rapid rate. Airplanes can volplane down safely if the engine stops, as their superior wing surface allows of their doing so; but perhaps the inventors of the Helicopter here shown have circumnavigated this problem in a manner which they have kept to themselves so far.

Those interested in trying out the merits of the Helicopter flying machine will find a most interesting article on a successful flying model of this type, by Mr. William J. Beach, in another part of this journal.

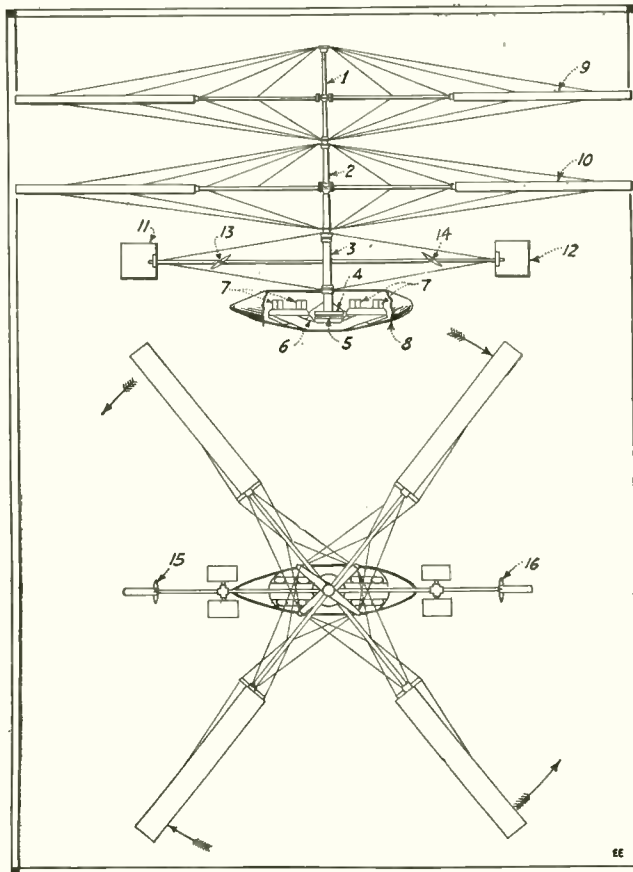

1. Inner Concentric Shaft Which Rotates Upper Propeller, 9.
 2. Outer Concentric Shaft Which Rotates the Lower Propeller, 10.
 3. Permanent Tubular Sleeve Which Takes the Weight of the Machine and Alternately Bears the Lift and Compression Loads When the Craft Is Flying or at Rest.
 4. Upper Wheel of Reducing Gear.
 5. Lower Wheel of Reducing Gear. The Geared Pinions on the Engine Shafts Are Introduced Between These Wheels and Drive Them Equally. The Shaft of the Lower Propeller Is Secured to the Upper Wheel and the Shaft of the Upper Propeller Is Attached to the Lower Gear.
 6. Engine Foundation Structure.
 7, 7. Aviation Motors.
 8. Fuselage.
 11 and 12. Rudders That Can Be Swung Both Horizontally and Tipped to the Right or Left from the Vertical. By Tipping Them Oppositely, the Down Draft from the Propellers Tends to Rotate the Fuselage So That the Craft Will Swing to Port or Starboard. By Tipping No. 11 So That the Rudder Face Is Vertical Instead of Horizontal the Machine Is Inclined by the Head and Will Then Advance Horizontally in that Direction. Similarly So Inclining No. 12 Will Cause the Helicopter to Travel Rearward.
 After the Craft Is Started Horizontally at Any Angle of Advance, the Rudders 13 and 14 Are Set Oppositely, Thus Forming a Dynamic Couple Which Tends to Hold the Machine Inclined and Upon the Desired Line of Travel.
 15 and 16. Rudder Yokes.

electric motors. It is only necessary to tip the machine a matter of about five degrees toward the bow or toward the stern, to propel it at high speed in either of these directions. This tipping action is effected by suitable rudders; and when the helicop-

Is the Electric Airplane Possible?

HENRY WOODHOUSE, the well-known aviation expert, recently gave out a report that there had been plans disclosed in Chicago for a radically new type of flying craft, to be propelled by electricity entirely, and therefore to be of such great power and efficiency as to be able to make flight around the world.

This wonderful new flying machine, he said, was designed for propulsion thru the air by electric motors driving the propeller blades, with a total horsepower of 6,000. The airplane is also credited with being capable of carrying from 75 to 100 passengers, and the wings are to have a spread of 240 feet, while the airship itself is 180 feet in length. The appearance of this new flying craft is shown in the accompanying illustration.

WHAT DR. WILLIAM WHITNEY CHRISTMAS THINKS OF THE ELECTRIC AIRPLANE.

Before going further, it would be well to listen to what a leading aviation expert, Dr. William Whitney Christmas of New York, has to say with respect to electrically-driven airplanes. Dr. Christmas is the inventor of the famous "Christmas Bullet," whose cantilever supporting wings are flexible like a bird's, but not to the same extent. The "Christmas Bullet" is the fastest plane in the world and has made 200 miles an hour on official test, when fitted with a liberty motor. Recent unofficial reports from France, mention a new record for an airplane flight of 226 miles per hour. Dr. Christmas has been connected with aviation matters from the days of Professor Langley, and his views upon the subject of airplanes are therefore of interest to us.

Dr. Christmas said: "In suggesting that airplanes be driven by electricity, I realize that I am making myself open to severe condemnation by many well informed gentlemen who say that it cannot be done. Nevertheless, I am of the opinion that the ultimate craft of the air will be electrically driven.

"It is not my part to say how this is going to be accomplished, but to argue from the present failings of the aviation gas engine to the conveniences of electric motors.

"As is well known, an airplane depends upon its motor to stay in the air and the very delicate adjustments required on common aviation motors make them not entirely reliable. There are so many parts that can wear out or get out of adjustment,

What An Eminent Airplane Engineer Says

that it is a wonder they show up as well as they do.

"I do not mean that they are altogether unsatisfactory, but I do say that they can be improved upon by substituting a common electric motor.

"The electric motor is compact. While the present day motors are heavier and bulkier per horsepower than most aviation engines, this is because aviation engines have been refined for the particular service on airplanes and electric motors have not. Now if our electrical geniuses put their heads down to the job of developing a fine aviation motor, they will doubtless come within the same limits that the gas engine men have attained.

"The problem of supplying the electric energy to the motor on electrically-driven airplanes is, as we might surmise, some problem! However, it is not insolvable, and there are three obvious ways to be suggested. One—to carry storage batteries; two—to transfer electrical energy by *wire* or *wireless*, i. e., as by means of a depending trolley cable between the airplane and a contact or third rail, over the contact rails of which would run a contact shoe at the lower end of the cable; and the wireless transmission of energy, referring to the ideas of Dr. Nikola Tesla, of course not developed yet to the stage of practicability; and third—a gasoline-electric airplane in which great constancy of power and beautiful control of driving screws are obtainable. In this scheme the gasoline engines drive dynamos which generate electric current, and this current is then controlled as desired by the pilot, and fed to one or more electrically-driven motors to which the screws or propellers are attached."

THE GASOLINE-ELECTRIC AIRPLANE TO THE FORE.

As the accompanying illustration shows, the layout and arrangement of the electric propelling mechanism on the newly proposed airplane described by Mr. Woodhouse, is along well-known and thoroly tried engineering lines and corresponds to the electric drive on our newest battleships.

There is not a very great loss in converting the mechanical energy developed in the gasoline engines (of which there are two in this case) into electrical energy as

developed by the dynamos; and these losses are more than compensated for in applying the electrical drive to the airship, by virtue of the much smoother operating control and driving qualities. One thing is certain—that with this arrangement of gasoline-electric propulsion we know it will work!—providing we build our electric machinery sufficiently light, as Dr. Christmas has pointed out, so as not to over-burden the flying craft with useless dead-weight.

The *power-plant* here shown, comprises 6,000 horsepower of electric motors driving the four screws, or each motor produces 1,500 horsepower. The motors may be operated in pairs in case one generating set should fail, and therefore the two inside or else the two outside screws can be used.

The two dynamos develop 3,000 H.P. each and are driven by two 3,200 H.P. gasoline engines. The pilot in his cabin, atop the main body of the aircraft, has full control of the speed of the propelling screws at all times. Where the propellers can be so accurately and easily controlled, as in the case with the electric drive, the ease of handling of the airship is greatly enhanced, as for instance by speeding up the screws on one side, and reducing their speed on the other side, etc., especially in bad weather. With electrified airships there comes many other niceties for long distance journeys, such as electric cooking, electric heating, electricity for operating a powerful radio set, electric lights, and an electrical gyroscopic compass.

As will be noted from the illustration, the radio antenna in this machine follows the latest departure in this direction, and the wires constituting the antenna are placed inside the wings.

Objection might be raised on this point that there is considerable danger of fires owing to electric discharges from the antenna wires, but it might be said that the latest idea in building such machines is to cover the wings with sheet aluminum or aluminum alloy sheeting, in the same manner as some of the German and other foreign planes have been successfully built.

As will be seen, there is room for a limited amount of baggage on such an airplane, and for night trips, sleeping quarters may be provided on the order of the well-known Pullman car accommodations—that is, by converting the seats into berths. Powerful electric searchlights are available for flying at night, and especially for landing purposes, while port and starboard lights or *markers* are fitted on all such planes at the present time.

Heard German Conversation One Mile Away

It is a common knowledge, especially among men of the U. S. Signal Corps who served with the A. E. F., that by means of the wonderful 6, 8 and 10 stage audion amplifiers, available in the present war, and by placing a parallel loop of wire over a few hundred feet near the front lines, that enemy conversations could be easily and accurately intercepted and amplified. As we have just said, this phenomena is more or less well known, but it is not generally known, we believe, that, as recently pointed out by a U. S. radio expert who invented the amplifying radio buzzer system used in trench and field warfare car-

ried on by the Allied troops, it was possible by the use of the high power ten-step amplifiers, both French and American type, to overhear telephone conversation and also telegraphic signals whenever the Germans happened to communicate over wires, at a distance of one mile behind the front line trenches. Interrogated at this point, the expert explained that not such a long wire loop was necessary as might be supposed, but that a wire about 250 feet long, placed parallel to the German trenches, was all that was necessary, and just to show that the "Yanks" had the "Boche" on the run long before he en-

tered his trenches, underground dugouts and wine cellars, it is a matter of record that the Allied troops, in many instances, and particularly toward the close of the war, found whole sections of German telephone instruments over a considerable area near the front lines entirely sealed with red labels marked "Verboten," and, furthermore, some of the captives stated that their troops had been ordered not to use the telephone at all under any consideration, even where the wires were laid in iron pipes. Many other valuable uses were made of these eight and ten-step vacuum amplifiers, some of which will be described in future articles.

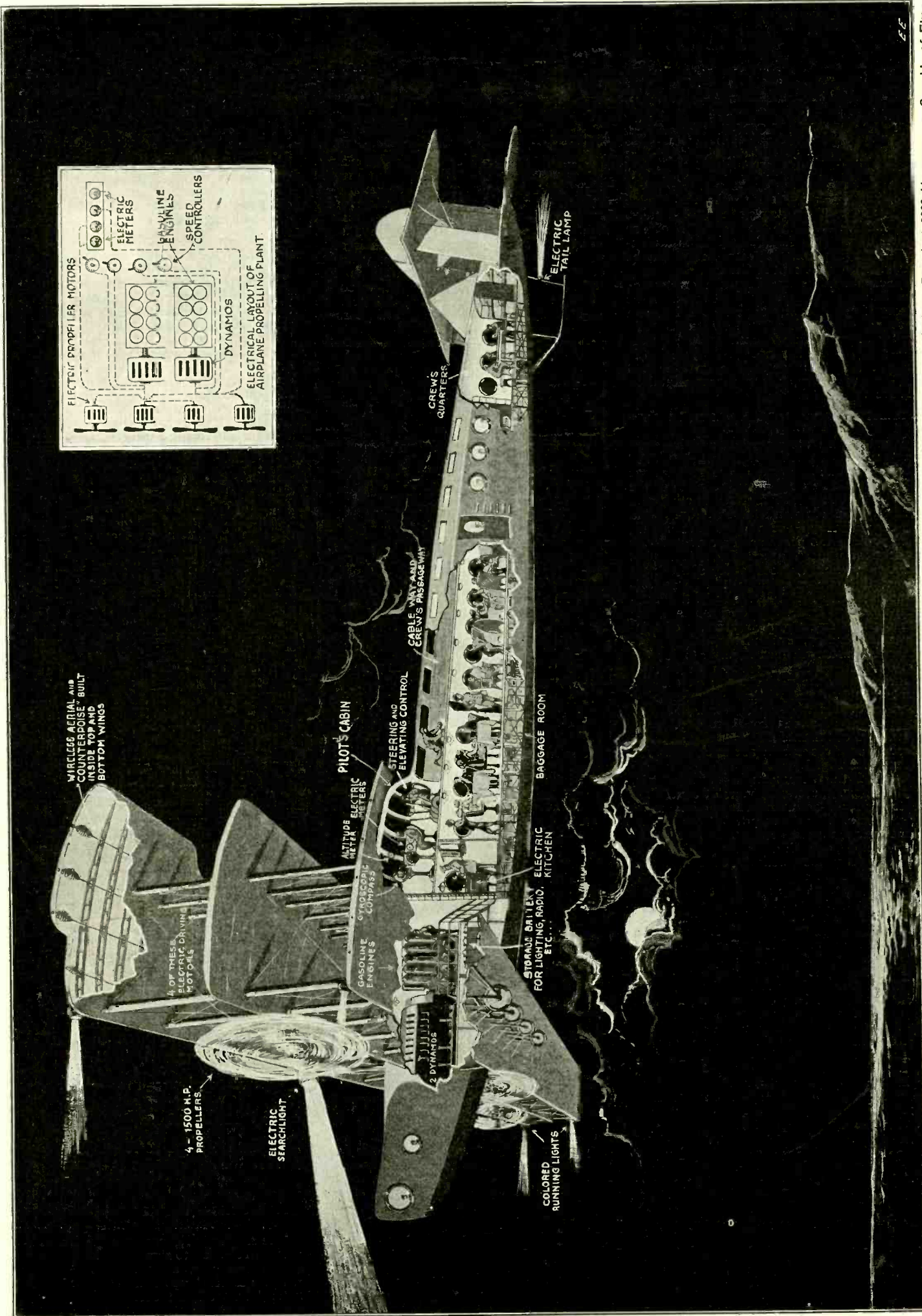

Electric Drive for Battleships Has Proven Eminently Satisfactory; Why Not Try It for Aircraft? Here We Have a Newly Proposed Electric Drive Airplane Rated at 6000 Horsepower, Capable of Flying Across the Continent with a Load of 100 Passengers and Baggage. Inset Cut Shows Electric Control Features.

EE

What Atomic Forces Could Do

SIR OLIVER LODGE, the eminent English scientist, declared recently that the first utilization of basic atomic properties of matter, had first been utilized by man in wireless telephony. This refers to the remarkable electronic action occurring in Audion bulbs. He added, that if the atomic energy of one ounce of matter could be utilized in a practical everyday sense by man, it would be sufficient to raise all the German ships sunk in Scapa Flow and pile them on top of the Scottish mountains. In conclusion he stated that it was his hope that the human race would not discover how to use this vast store of energy until it had brains enough to apply it properly, because if the discovery were made before its time and by the wrong people, this planet would be unsafe to live on.

RADIUM WATCH DIAL A VEST-POCKET POWER-PLANT.

What is this atomic force and have we any means of seeing it at work today? Thanks to Radium and Radio-activity, we have a means of demonstrating some of the wonderful effects of sub-atomic activity on a small scale. If you own a radium dial watch with luminous figures and hands, then you are the possessor of a vast power plant of no mean proportions. There is sufficient radium on your watch dial to haul you train homeward, if it could be properly applied. As the matter stands, the innocent-looking radium dial does not seem to possess any extraordinary amount of concentrated energy, but this is only apparently the case, and not actually so; for the reason that while the amount of activity manifested by the radium paint on the dial is small, this effect will keep up for 2,500 years, provided the zinc sulfid, with which the radium is mixed so as to produce a glow, held out that long. The zinc sulfid in most cases gives out in about eight to ten years. See Fig. 1.

One of the accompanying illustrations, Fig. 2, shows a sectional view of a very interesting radio-active instrument known as the "Crookes Spintharoscope." This instrument which is a simple and inexpensive device, demonstrates in a most beautiful manner the marvelous activity of radium or any radio-active salts.

It comprises an eye lens-piece, as shown, which can be adjusted to different focuses, and in the bottom of the tube there is placed a zinc sulfid screen. Just in front of this screen there is placed a tiny speck of some radio-active substance. The needle holding this substance is usually mounted on an adjustment nut. This spintharoscope, when viewed thru the lens opening in the dark, presents a most wonderful spectacle, as hundreds of the atomic particles, thrown off continuously from the radio-active substance, bombard the zinc sulfid screen; each spot at which a particle strikes the screen lighting up, until the whole interior of the spintharoscope resembles a veritable fireworks display.

THE STRUCTURE OF THE ATOM.

The modern idea of the structure of an atom as well as the *family tree* of the atom and molecule are shown in Figs. 3 and 4. Referring to Fig. 3 we see that the atom, which was the smallest known sub-division of matter a few years ago, is composed of a *positive* electric charge or *nucleus*, around which there are constantly rotating at tremendous velocity, a certain number of *electrons* or *negative* electric charges. This idea of the atomic structure is believed in by practically all of the leading scientists of today, including such men as Millikan.

There are some scientists who raise the question as to whether or not the electron is really the ultimate sub-division of matter. Some scientists think the electron may in turn be composed of a series of small electric charges, and that these charges may represent the ultimate particles of matter. Fig. 4 shows the whole electron family. First we have the molecule, which is composed of atoms,—then the atom, which is composed of electrons—and finally the electron, which may be easily composed of ultimate ether particles—which latter are thought by some physical investigators to

the atom, that we depend for the different substances or elements which we have today, such as iron, tin, copper, gold, silver, etc. Every ounce of matter that we know of today, including our very bodies, is composed of millions of billions of these ever-whirling electrons, so our scientists tell us.

DIFFERENCE BETWEEN BREAD AND IRON ONE OF ATOMIC STRUCTURE.

Thus, we see that the difference between a piece of bread and a piece of iron—is that one has a different electronic structure than the other. Aluminum, for example, has a different number of electrons whirling around its atomic nuclei than does gold or iron. It has been intimated by some of our ablest scientists that the dream of the Alchemists of old would surely come to pass, once we master the key to the atomic structure. For if we can apply, let us say, a powerful electric charge to a certain substance so as to alter its electronic and atomic formation, then we can turn lead or iron into gold, but we have no such control as yet over the electron family circle. Thus we cannot cause them to combine in any desired pattern, altho we are beginning to learn what some of these patterns are, at any rate.

As Professor Millikan has shown, as well as other investigators, there is apparently a vast amount of space between the electrons in an atom and experiments have been made which have demonstrated this phenomenon to a very remarkable degree. Free electrons have been shot thru an atom without touching any of the other electrons in that atom, or without dislodging any of them, and past on over a considerable distance before coming to rest.

Fig. 5 illustrates Sir Oliver Lodge's prediction of what might occur if we understood how to produce atomic disintegration and realize the tremendous, almost inconceivable power locked up in the atom—that is, we could raise all the German ships that were sunk in the Scapa Flow atop the Scottish mountains.

It is interesting to learn of some other remarkable results that could be accomplished by atomic disintegration. As Soddy shows, radium gives off heat at the rate of 133 gram calories per hour, or in the 2,500 years of its life (half-period of decay) it will yield the stupendous total of 2,900,000,000 gram calories per gram of pure radium. The calculation data on the steam locomotive were kindly supplied by Mr. H. S. Vincent, of the Engineering Department of the American Locomotive Co. An interesting computation shows that five ounces of this precious stuff, which you can hold in your hand, would propel a standard passenger train of 10 Pullman cars from New York to Chicago, a distance of 908 miles by railroad. How many tons of coal do you think it takes to drive such a train over a 900-mile, 22-hour journey? It requires 60 tons of the best anthracite coal to make one trip from New York to Chicago or vice versa. Such a train averages 41 miles per hour and the steam passenger engine used for the trip develops an average of 1,600 horse-power. The engine is rated at 2,200 horse-power.

FIVE OUNCES RADIUM WOULD DRIVE TRAIN 900 MILES.

The manner of computing the amount of radium required to duplicate the work of a 60-ton coal pile, measuring 67 feet high, with a base 10 by 10 feet, as shown at Fig. 6, is based on the assumption that each

(Continued on page 934)

For "February"

How I Discovered Radioactivity—Feature illustrated article specially written by Prof. Becquerel.

The Giant Canadian Reflector—Second Paper on Large Telescopes and How They Work, by Prof. Floyd L. Darrow.

When Weight is Zero. By H. Gernsback.

The Audion as a Scientific Magician—What it has done and is doing. Prepared in collaboration with Dr. Lee de Forest.

The Dark Searchlight—Taking "Movies" by invisible light rays, by Lewis Yeager, its inventor.

New Experimental Chemistry Series. No. 1, Alcohol—To be conducted by Prof. Floyd L. Darrow.

Radium—the Wonder-Substance—Some unusual and simple experiments illustrated and interestingly told, by Harold F. Richards, A.M.

The New Theory of Electrical Mass, by Rogers D. Rusk, M.A.

Building Model Airplane Motor of the Rotary Comprest Air Type, by W. J. Beach, M.E.

A New Commutator-less A. C. and D. C. Machine, by Richard A. Engler.

Radiotelephony and the Airplane, with diagrams, by William C. Mundt.

Audion Hook-ups—a page of them—Centralized battery connections for grid and filament, and hosts of others.

be without weight. In other words, these *ultra-particles* would merely be *ether whorls*.

Now we are coming to the point that Sir Oliver Lodge had in mind when he made the statement cited in the forepart of this article. What he meant when he intimated what tremendous amount of energy would accrue to mankind if we could only unlock the secret of the atomic structure, was this: That instead of having to wait thousands, or hundreds of thousands of years, for atomic structures to form of their own accord, that we should be able to *re-arrange the formation of the electrons in the atom*. For it is upon the number of electrons and their arrangement in

SIR OLIVER LODGE—"ONE OUNCE OF MATTER IF ATOMICALLY DISINTEGRATED, WOULD DEVELOP ENOUGH ENERGY TO RAISE THE GERMAN SHIPS SUNK IN SCAPA FLOW ATOP THE SCOTTISH MOUNTAINS

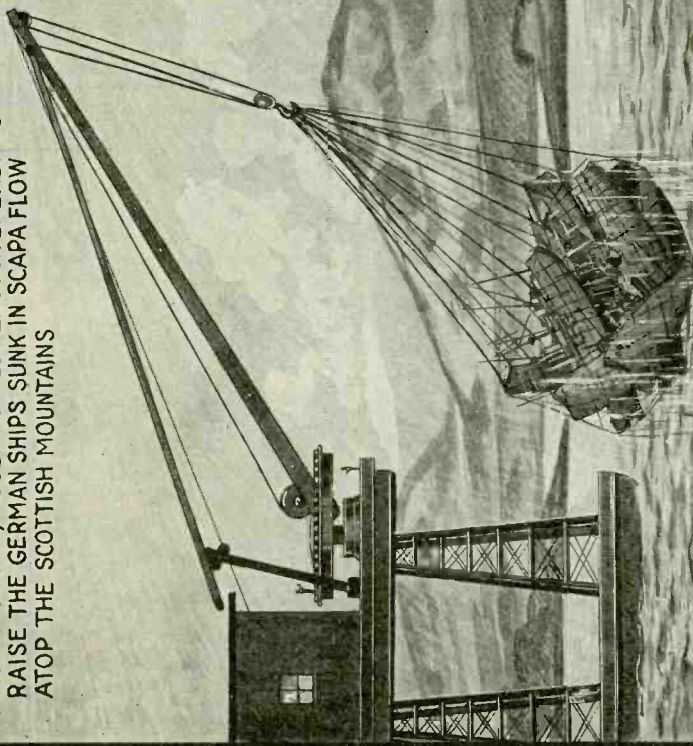

60 TONS ANTHRACITE COAL REQUIRED FOR 1 TRIP NEW YORK TO CHICAGO

COAL PILE 67 FT. HIGH

THIS MAN HOLDS IN HIS HAND 5 OZ. OF PURE RADIUM, WHICH IF DISINTEGRATED DURING THE RUN, WOULD DRIVE THE CHICAGO FLYER OVER ITS 900 MILE JOURNEY, DEVELOPING 1600 H.P. FOR 22 HRS. TOTAL HEAT IN GRAM RADIUM = 408,240,000,000. A GRAM OF RADIUM IN ITS LIFETIME DEVELOPS 2,900,000,000 GRAM CALORIES 1 GRAM RADIUM WEIGHS 1/28 OZ. AVD.

99% OF THE COAL ENERGY IS LOST IN HEAT RADIATION AND LOSSES. 7% ONLY SAVED TO RUN LOCOMOTIVE

THE NEW YORK TO CHICAGO TRAIN IN ITS 22 HOUR JOURNEY, CONSUMES 60 TONS OF COAL, TRAVELING 908 MILES AT AN AVERAGE SPEED OF 41 MI. PER HOUR. THE ENGINE DEVELOPS AN AVERAGE OF 1600 H.P. FOR 22 HRS.

THE COAL BURNED WOULD KEEP 20 SMALL FAMILIES ALL WINTER. IT DEVELOPS 13,500 B.T.U. PER LB. OR A TOTAL 3,402,000 GRAM CALORIES PER LB. A TOTAL OF 408,240,000,000 GRAM CALORIES FOR 60 TONS

908 MILES RAILROAD ROUTE TO CHICAGO



CHICAGO

CAP



"THE 'RADIUM DIALED' WATCH CONTAINS ENOUGH ATOMIC ENERGY, IF DISINTEGRATED TO DRIVE YOUR RAILROAD TRAIN HOME, COMMUTERS

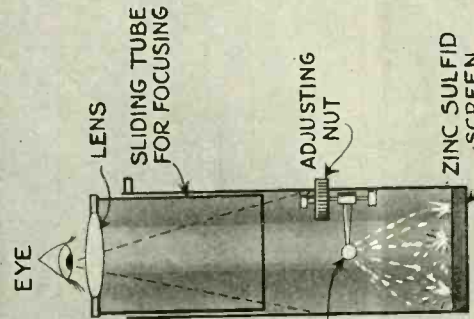

THE CROOKES SPINTHARSCOPE WHICH SHOWS US THE SLOW DISINTEGRATION OF RADIUM

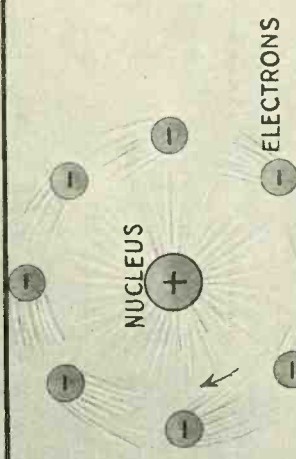

MODERN IDEA OF STRUCTURE OF AN ATOM A RING OF NEGATIVE CHARGES (ELECTRONS) ROTATING AROUND A POSITIVE 'NUCLEUS'



THE ELECTRON FAMILY

Some of the Marvels of Modern Science that are Happening Every Day in Their Own Way, and which could be made to perform the gigantic feats of strength shown in the short time noted. If our scientists could only master the secret of the electron and atomic structure, your 'Radium watch' is a young power house—but you don't realize it, because nature causes the energy to be given off at a very slow rate.

Electric Locos Cross Mountains

AMERICA has blazed the trail in many of the world's greatest engineering projects and accomplishments, and it has remained for one of the great western railways of the United States to electrify the longest stretch of trunk line in the world, and which within a short time will extend over a distance of about 850 miles. This route extends over some of the steepest ranges of our western mountains. The enterprising railroad which has had the foresight and courage to attempt such a gigantic electrification scheme as this, is the Chicago, Milwaukee and St. Paul Railway, whose tracks pass thru the thriving cities of St. Paul, Minneapolis, Butte, and Spokane. The section of this railroad running between Harlowton, Montana, and Avery, Idaho, 440 miles trunk line distance, and passing over the great Continental Divide, has been in electrical operation for some time. Work has been under way for several years on the electrification of the main trunk lines passing over the Cascade Mountains in Washington, between Othello and Puget Sound to Seattle, a distance of 211 miles. Electric current has recently been turned on the 110 mile stretch of this system, extending from Othello to Cle Elum, as shown in the accompanying illustration.

By the first part of the year 1920, it is expected to "open up" the electrified section of the road from Cle Elum to Seattle, or about 130 miles. This will then give a completely electrified trunk line for a distance of about 680 miles. As becomes evident, this leaves a gap of non-electrified or steam operated trunk line, extending from Avery to Othello, approximately 220 miles, which for the present will be operated with steam driven locomotives. However, a grand scheme of electrification has been mapped out by the engineers of the C. M. & St. P. system, for the complete electrification of the entire trunk line between Harlowton, Montana, and the Pacific coast, that is, Seattle and Tacoma, which will give a total electrified route of about 900 miles; this means one way direct trunk line mileage and does not include auxiliary trackage such as spurs, switches, yard tracks, etc., which would make a total of about 1000 miles of electrified track. When the complete electrification is effected within a year or two, when railroad matters have become more stabilized than they are at present, due to the government operation of railroads which has markedly curtailed the gigantic improvements which would have taken place otherwise, this system will have succeeded in electrifying within 200 miles, one-half of the entire mileage of the St. Paul-Seattle line.

It would be considered a wonderful feat of electric railway engineering, even if this great length of trackage had been electrified or was about to be electrified, over a stretch of level country, but one glance at the profile view on the opposite page showing the severe grades met with in climbing the stiff mountain ranges, will give some slight idea of the titanic task encountered in the "engineering" of this vast 20th century development.

Previously steam locomotives, the largest ever built, puffed and snorted painfully over these mountain trails. In the winter time, when snow and ice descended in the passes to depths of 15 to 20 feet, and the mercury in the thermometer slipped out of sight, the only thing the steam engines could do was to stand fast on the track and freeze up, so severe were the winter-time

operating conditions; this was often the actual experience of the C. M. & St. Paul Railway. It has happened many times since this system has been operating with electric locomotives, that one of these "electric steeds of the rail" has been sent out to haul in a disabled and frozen up steam engine.

In the accompanying illustration several interesting comparisons, of steam and electrified railroad systems, are vividly depicted. The two locomotives, one electric, and the other steam-driven, here illustrated, tell the story of the wonderful advance in railroading over the vast stretches of our western plains and mountains from the year 1848, when the first steam engine, "Bob Ellis", here shown, proudly hauled the first train of cars over Wisconsin rails, up to the present day, when the gigantic electric locomotive here shown, swings up and over the precipitous mountain paths and on to the coast, 850 miles thru America's most gorgeous scenery.

The electric power for operating this electrified railroad system, is derived from vast water-power developments, which have been brought to their present stage of efficiency by the Montana Power Company. The electrical power supply utilized in operating the 440 miles of electrified trunk line, between Harlowton and Avery, and the 160 miles of electrified spur and yard trackage in Montana, is obtained from the hydro-electric power plants of the Montana Power Co., whose main plant is located at Great Falls, Montana. The electric power for operating trains over the Cascade district will be obtained from hydro-electric developments at Long Lake, Snoqualmie Falls and possibly Priest Rapids on the Columbia River. The electric current from the water-power generating stations is delivered in the form of 100,000 volt alternating current. With this high potential the tremendous losses are brought to a very low minimum, and electric power may be transmitted for a great distance, even 200 miles or more, when necessary. The electric power for operating the mountain district for example, is delivered at 100,000 volts potential over transmission wires strung along the route on steel towers and is distributed along the way to 14 sub-stations. The purpose of these sub-stations is to pass the 100,000 volt ultra-high potential alternating current into transformers and thence into rotary transformers, which convert it to a much lower tension direct current, or one having a potential of but 3,000 volts; as but 1,800 to 2,000 volts is required to kill a man in the electric chair, it may readily be judged what a tremendous potential 100,000 volts really is! The sub-stations thus perform two important functions—they transform the 100,000 volt current down to one of 3,000 volts, which can be more safely used in operating the motors on the locomotive, and besides—they change the alternating current to a direct or a continuous one.

The alternating current pulsates or rather alternates from positive to negative about 120 times per second, while the direct or continuous current passes in the same direction continuously, i.e., one wire is positive and the other negative all the time, while with alternating current, such as used in the main 100,000 volt transmission lines, the wires become charged positive and negative, alternately, 120 times per second. Motor-generators are used in each sub-station, the stepped-down alternating current from the transformers operating an A. C.

motor, which motor is connected directly on the same shaft with two direct current, 3,000 volt generators. The two D. C. generators are connected in series and deliver 3,000 volts D. C. to the over-head trolley wires from which the electric giants of the rail derive their power; not thru the ordinary trolley pole, but by means of a very elaborate trolley contactor known as the *pantograph trolley*. The advantage of this trolley contactor is that on curves and also on high speeds for straight runs, there is only a slight probability of the trolley losing contact with the wire. The ordinary city or suburban trolleys use but 550 volts D. C.

ELECTRIC EQUIPMENT.

Under normal conditions, forty-two powerful electrical locomotives are required to haul freight and passenger trains over the electrified mountain districts of the Chicago, Milwaukee & St. Paul Railway. These locomotives each cost approximately \$112,000; they weigh 284 tons each and will haul 3,200-ton loads, trailing up a 1 per cent. grade at an average speed of sixteen miles an hour. Similar electric locomotives, geared for greater speed, will haul 800-ton passenger trains over the same stretch at a speed of sixty miles per hour. To appreciate the immense tractive power of these electrical "Goliaths" one should know that the wood-burning locomotive of fifty years ago weighed twenty tons and had a tractive power of only 5,000 pounds! The present-day big Mallet steam locomotive has a tractive power of 76,200 pounds and the electrical locomotive, weighing 284 tons, has a tractive power of 85,000 pounds. These electrical locomotives are 112 feet, 8 inches long, and are driven by separate motors, twin geared to each of eight pairs of driving wheels. The cab extends nearly the whole length of the locomotive.

REGENERATIVE BRAKING.

Regenerative braking applies to a method used on down grades, by which the train, instead of consuming electricity, actually produces it while traveling onward, and by which, at the same time, the speed of the train is kept under perfect control.

This is the first use ever made of direct current regenerative braking, and the following from an authority on the subject explains its functions:

"Electric motors are reversible in their function, namely; while they absorb electrical energy and give out mechanical energy going up grades, they can reverse this operation and absorb the mechanical energy given the train down grade by gravity, and transfer it into electrical energy. Thus the electric locomotive provides a perfect braking system, which is independent and separate from the air brakes, which are used only in emergency and for stopping trains. Electric energy so generated can be turned into the trolley wire to assist other trains and reduce the amount of purchased electric current."

In actual operation, at the crest of the grade, the helper locomotive is brought to the front of the train and coupled with the forward locomotive, both being operated as one. The train is then controlled on the down grade by regenerative braking.

This system of braking provides maximum safety, eliminates wheel, brake-shoe and track wear and overheating; insures uniform speed on down grades, and re-

(Continued on page 931)

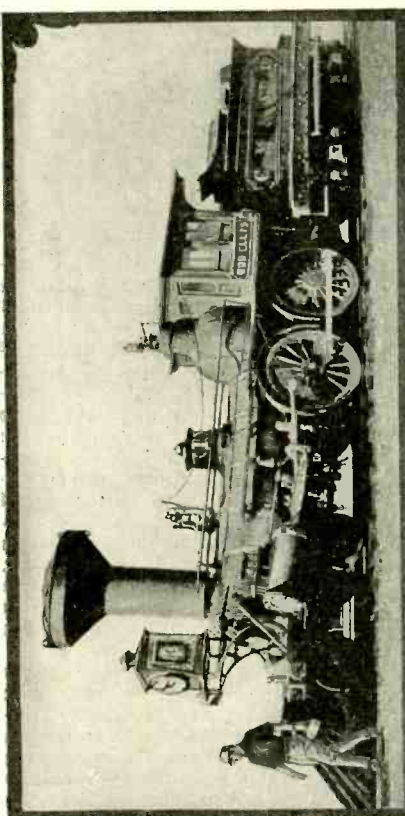

The Greatest Railroad Electrification in the World—The Chicago, Milwaukee and St. Paul System. When completed, this electrified Route will be at least 500 miles. The World's Mightiest Locomotive, propelled by Electricity, is with "Bob Ellis," at right, the first steam engine to turn a wheel in Wisconsin. Note the size of the man in each photo. "Bob Ellis," weighed 46,000 lbs., while the electric beam at 568,000 lbs. As the tractive or pulling power is proportional to the weight on the driving wheels, the power of the latter is at once apparent.

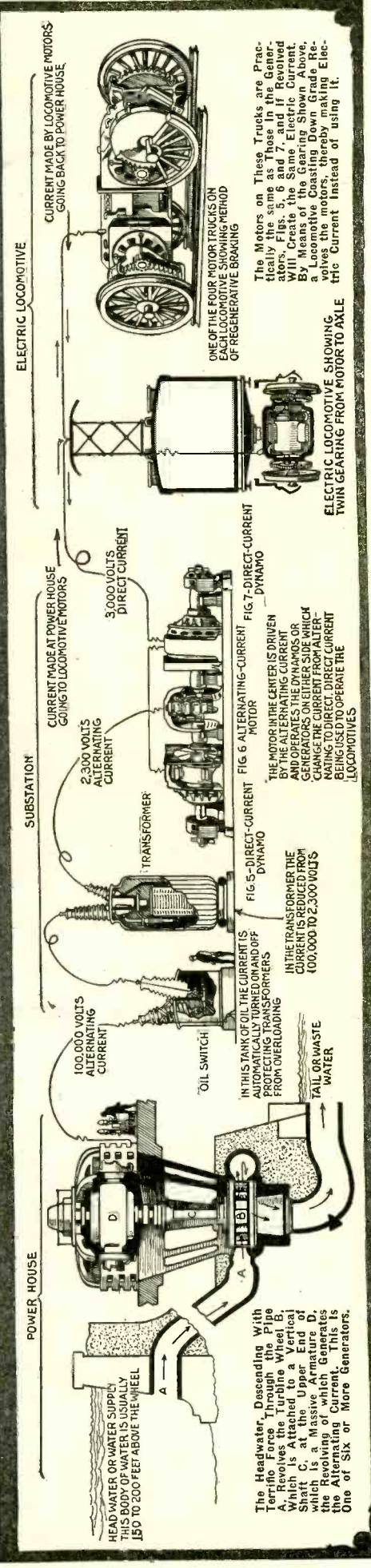
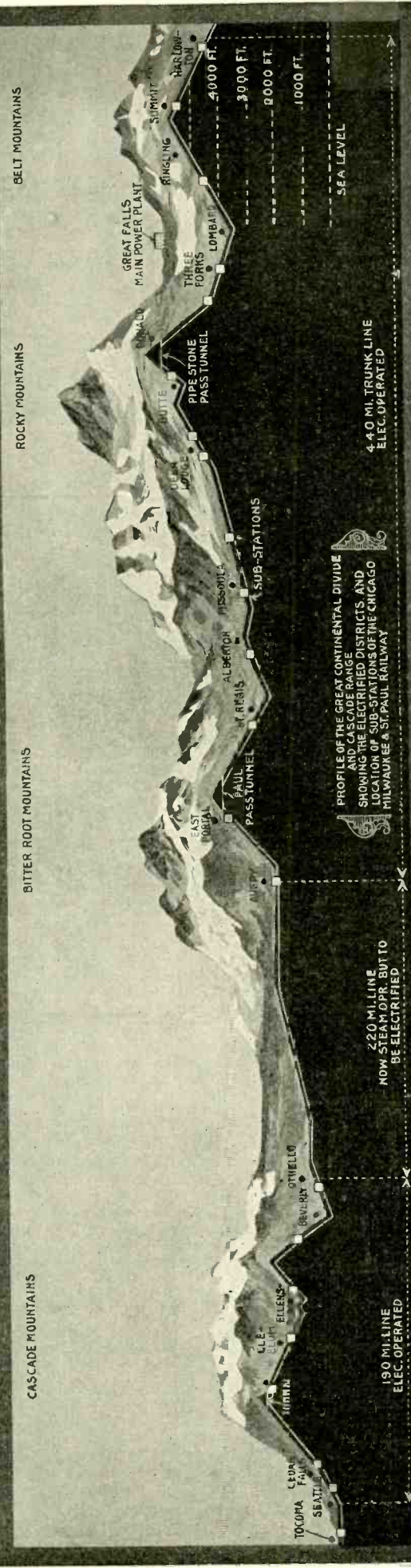
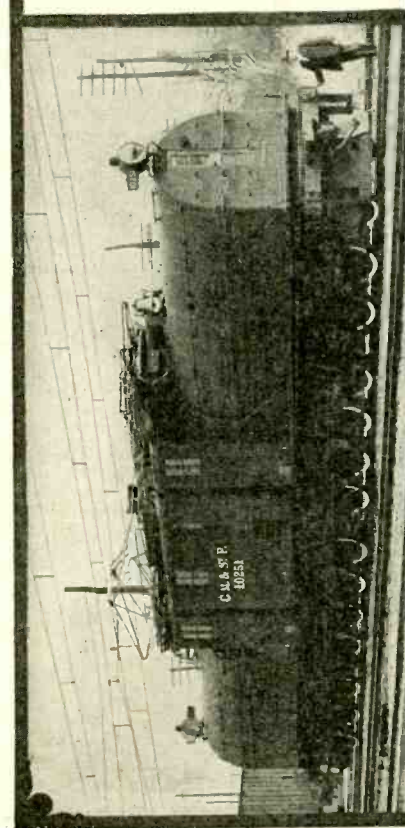

SERIES OF VIEWS SHOWING THE MANNER IN WHICH WATER POWER TRANSFORMED INTO ELECTRIC POWER OPERATES "THE KING OF THE RAILS"

Magnetic Storms

By LINDLEY PYLE

Professor of Physics, Washington University, St. Louis, Mo.

How Sun Spots, Rain, Wind and Cloud Shadows Affect Earth's Magnetic Force

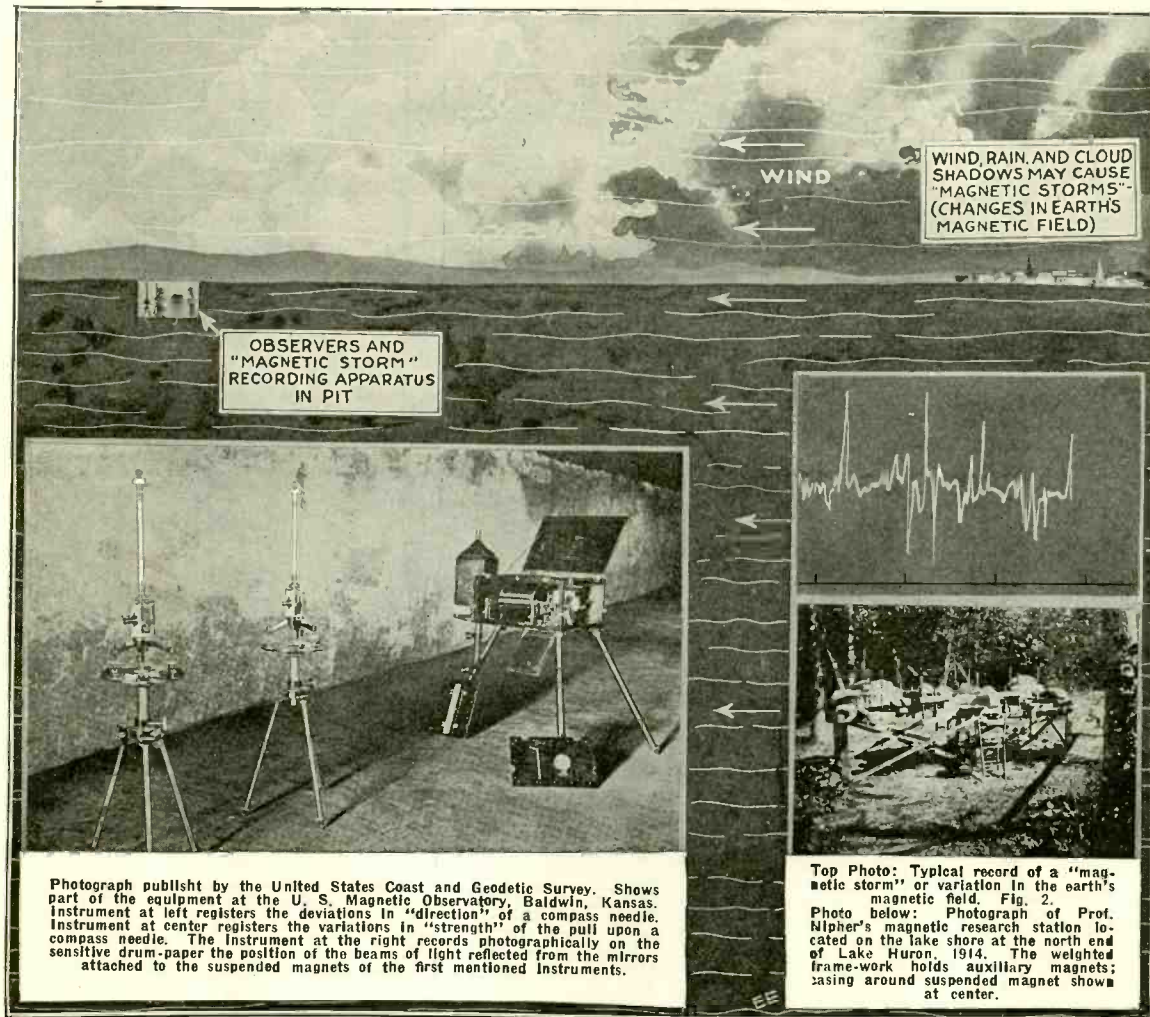

OBSERVERS AND "MAGNETIC STORM" RECORDING APPARATUS IN PIT

WIND, RAIN, AND CLOUD SHADOWS MAY CAUSE "MAGNETIC STORMS" (CHANGES IN EARTH'S MAGNETIC FIELD)

Top Photo: Typical record of a "magnetic storm" or variation in the earth's magnetic field. Fig. 2.

Photo below: Photograph of Prof. Nipher's magnetic research station located on the lake shore at the north end of Lake Huron, 1914. The weighted frame-work holds auxiliary magnets; casing around suspended magnet shows at center.

Photograph published by the United States Coast and Geodetic Survey. Shows part of the equipment at the U. S. Magnetic Observatory, Baldwin, Kansas. Instrument at left registers the deviations in "direction" of a compass needle. Instrument at center registers the variations in "strength" of the pull upon a compass needle. The instrument at the right records photographically on the sensitive drum-paper the position of the beams of light reflected from the mirrors attached to the suspended magnets of the first mentioned instruments.

and is a slow progressive change with lapse of time. The diurnal change is one that has a daily cycle or period and is repeated day after day. It was discovered in 1722 and is no doubt related to the ionizing action of sunlight upon the atmosphere. The annual change is likewise a recurring change, but is repeated every year. It is a small variation and is without doubt due to forces situated outside the earth.

The present paper deals primarily with the Irregular Fluctuations, commonly termed "Magnetic Storms." These are small, irregular fluctuations which may be especially marked for a duration of a few seconds, a few hours, or even for several days.

MAGNETIC STORMS CAUSED BY WIND, RAIN, CLOUD SHADOWS AND SUN SPOTS.

Just as a rain storm may be a purely local affair or may cover half a continent, so may a magnetic storm be purely local in origin or world wide in scope. In November, 1882, near the period of maximum sun spots, a magnetic storm occurred at the same moment over the entire earth. Such disturb-

MAN is so constituted that his organism is sensitive to certain types of energy transmission and insensitive to others. Our bodies are able to detect changes in temperature, changes in wind velocity, changes in humidity, changes in intensity of a light source, and our thermometers, anemometers, hygrometers and photometers are devised to measure these things. Our bodies are insensitive to the slow and continuous changes in atmospheric pressure as indicated by our barometers and barographs, tho we do respond to quick changes in pressure such as we experience in the rapid ascent or descent of elevators in skyscrapers. But there are cases where only our inanimate instruments are able to detect the presence of some physical agents and variations therein.

One of the most notable cases is that of the magnetic field,—a man can thrust his hand into the airgap of a powerful electromagnet and experience no sensation whatever. Of course when the body, which is an electrical conductor, is placed in a varying magnetic field there must be induced electrical currents set up in the tissues. Some experimenters have claimed to have detected the effects of these currents as set up by very powerful alternating magnetic fields, but the question may still be consid-

ered an open one. However, we are on sure ground when we state that the human organism is not directly aware of the magnetic field of the earth, and without the aid of special apparatus would be as unaware of it as if it were absolutely non-existent. But the *compass needle* furnishes irrefutable evidence of the presence of this mysterious ether phenomenon.

At any chosen geographical location close observation shows that the compass needle undergoes continuous fluctuations corresponding to changes in direction and strength of the earth's magnetic field. These changes may be classed as (I) Regular Fluctuations, and (II) Irregular Fluctuations. The first-named may be grouped under three principal sub-heads: (a) Secular, (b) Diurnal, and (c) Annual. The secular change has been known since 1634

ances are usually accompanied by auroral (Continued on page 920)

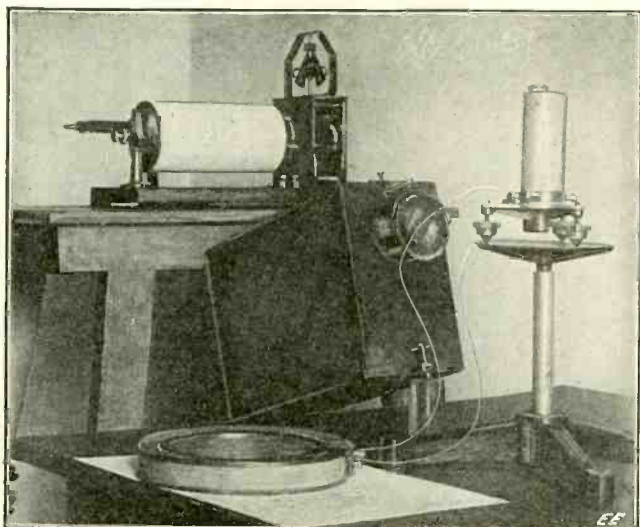

Electrical Apparatus Devised by the Writer of the Present Article for Recording the Effect of "Magnetic Storms" or Fluctuations in the Earth's Magnetic Field. See Also Fig. 1-A for Connections.

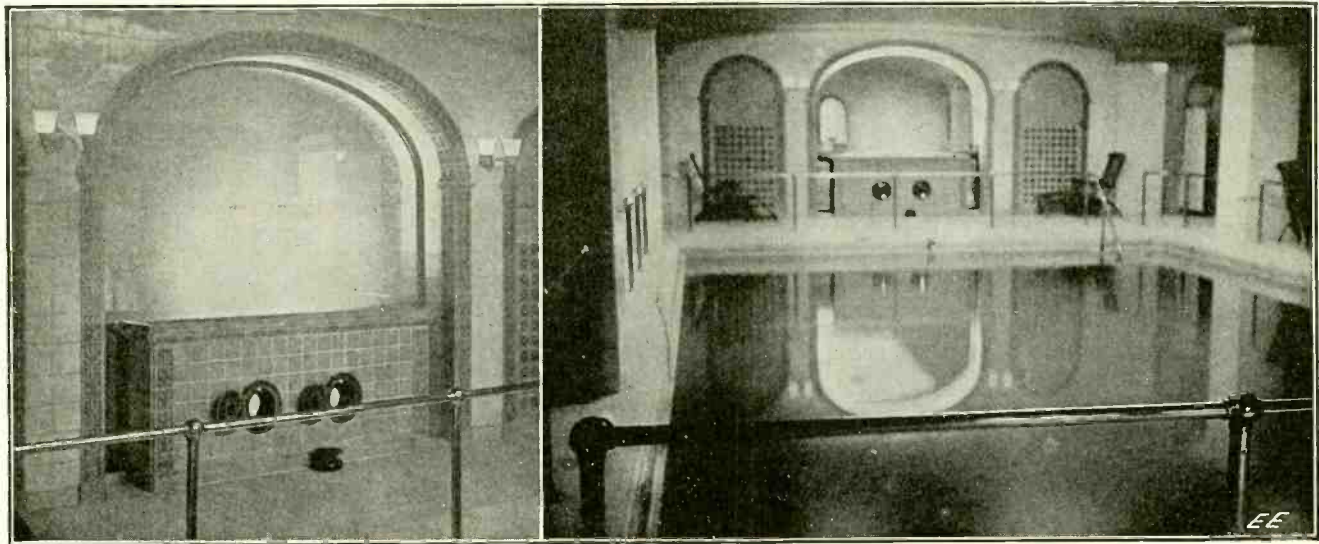

The Above Views Show the Large Men's Swimming Pool at the Hotel Pennsylvania, New York City. At the Left, and Also in the Center at the Right-Hand View, May be Seen the Tile-Covered Water Purifying Apparatus, the Ultra-Violet Ray Tubes of Which Sterilize All the Water in the Swimming Tank Continuously. Electrically Operated Ultra-Violet Ray Tubes Accomplish This Result.

Swimming Pool Purified by Electric Rays

By JOSEPH H. KRAUS

OF the thousands of people who frequent swimming pools every year, how many realize the fact that such bodies of water, both indoors and outdoors, are polluted with germs and bacteria of all kinds? A bacteriologist can at any time secure water from such a pool and upon making a germ culture, will find it filled with the bacteria of various diseases such as influenza, typhoid, enteritis, diphtheria, Asiatic cholera, peritonitis, tetanus, etc., and seldom do people believe that they have obtained the disease from polluted waters, preferring to accuse any other source than to think of the possibility of "catching something" from an innocent-looking swimming pool.

One hotel management in New York has shown foresight enough to know that such is actually the case, and that disease germs do breed and lurk in the water of pools; even drinking water being full of the germs mentioned, and various other lesser cultures, too numerous to mention. Therefore, instead of using the water directly from the main pipes, they installed an ultra-violet ray sterilizing apparatus which completely sterilizes the water, so that the most exacting cultures of the water taken from the pool show a complete absence

How Ultra-Violet Rays Sterilize Swimming Pool Water

of all germs, fungi, and other poisons. This sterilizer consists essentially of a container thru which water is past, this apparatus being connected with the intake and exhaust water pipes, and a special type of electric lamp using 220 volts, which generates powerful ultra violet rays. These rays are generated and radiated thru a quartz tube surrounding a mercury vapor arc, as shown in the accompanying illustration.

Strange as it may seem, ultra violet rays have the peculiar property of a complete bactericidal agent, and pathogenic germs,

in fact all germs and fungi are completely destroyed by their action. These lamps were developed by Peter Cooper Hewitt in part; that is, he developed the mercury vapor arc and De Mare has first used it for water sterilization. This hotel uses 220 volts direct current for the operation of these lamps.

Ultra violet rays, altho invisible and intangible, are easily produced in very large quantities by quartz glass mercury vapor lamps. When started, the lamp is tilted, which breaks the mercury bridge and the arc is struck, whereupon the mercury is vaporized and the current passes thru the hot vapor, thus maintaining the arc. Not only is this method economy in itself, but it opens up a new branch of swimming pool water sterilization, inasmuch as by using proper filtering and circulating apparatus very good and sanitary water can be supplied indefinitely, as at the Hotel Pennsylvania in New York City. We do not mean to say that this hotel uses the same water indefinitely, but just cite this as an example showing that the same water could be used over and over again. The saying "that we swim in purer water than you drink at home" is quite correct. This apparatus also renders a pleasing atmosphere to the swimmers in the cool, inviting waters.

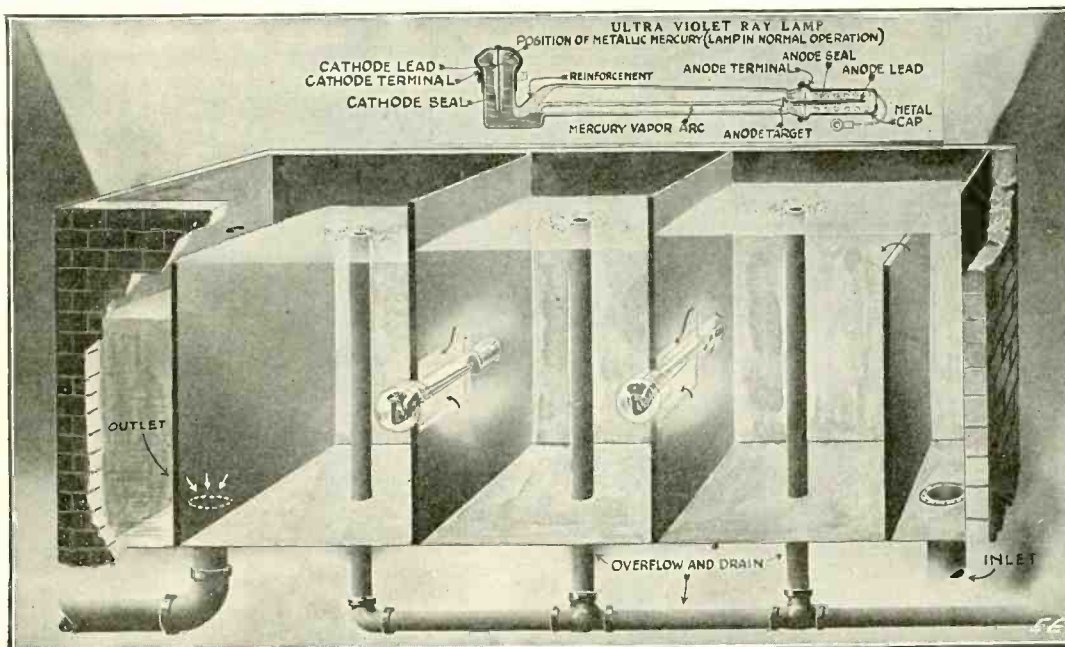

Sectional View Thru Ultra-Violet Ray Lamp Chamber With Partitions, Showing How the Water From the Swimming Pool Passes From the Inlet Pipe Thru the Successive Compartments, Where the Water Is Acted Upon and All Germs Killed by the Powerful Ultra-Violet Rays.

(Continued on page 939)

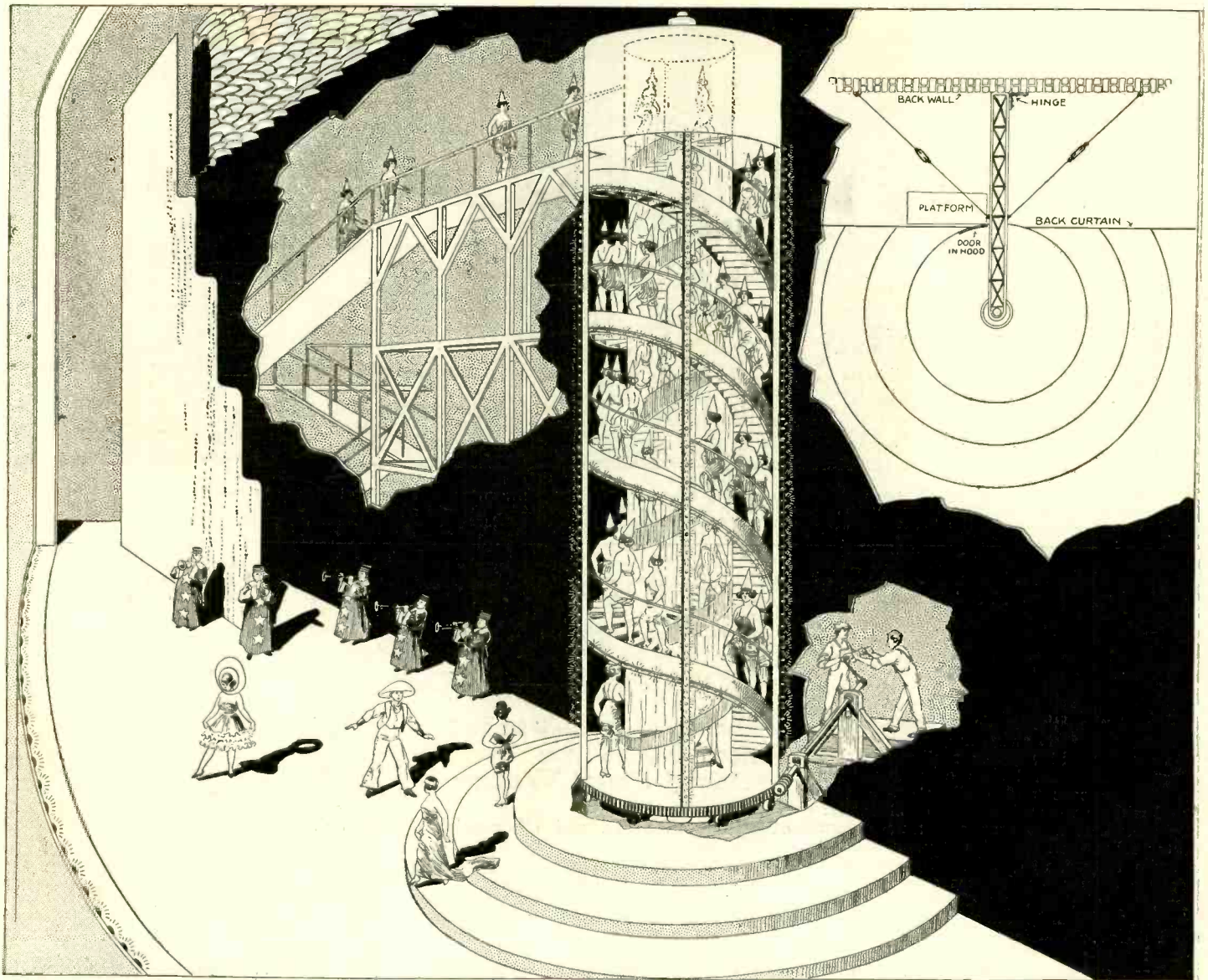

General View of the Capitol Theater Stage, New York City, Showing the Revolving Tower Effect Used. This Is Filled with Chorus Girls, Both Inside and Out, When It is in "Full Bloom." Electric Lights Are Used to Outline the Tower Structure. While One Line of Girls Ascend the Second Line is Descending, Producing a Beautiful and Entrancing Spectacle. The Capitol Theater Is the Largest in the World.

The World's Largest Theater

A BEAUTIFUL, new theater was recently opened in New York, which not only dwarfed picture palaces that now flank Broadway, but also out-ranks the theaters of the world. This particular assertion not only embraces the so-called legitimate theaters, but also the celebrated opera houses of the globe, including the far-famed and gorgeous *La Scala* at Milan, Italy.

This new theater, the "Capitol," is remarkable not only for its size, but in its location on one of the most valuable sites in creation, a \$3,000,000 plot, and in its unique combination of pictures and other forms of entertainment. It extends 109 feet on Broadway, 269 feet on 51st St., and thence 200 feet south to 50th St., where the stage is located. This feature in itself requires a frontage of 157 ft.

The theater presents an unbroken front of conventional, monumental design, ornamented by a solid row of pilasters, seventeen in number, the longest line adornment

in similar New York buildings. The auditorium is 175 feet wide and extends south towards the stage, a stretch of 159 feet. Its orchestra floor seats 2,750, and its balcony seats approximately the same number; or a total seating capacity of 5,300. The balcony is guiltless of the presence of a single supporting column, due thru the application of the most modern *Cantilever* building construction.

THE CAPITOL THEATER SHOW

The entertainment at this theater is unique and marvelous in that the manager has attempted to combine both "folly" novelties and high-class "motion pictures." The scene depicted in the photographs is from the closing scene of the "Ned Wayburn Review." The feature scenic effect is a remarkable revolving tower filled with girls.

This tower is shifted into position on a set of tracks from its resting place back stage, being mounted on a carriage which is mounted on wheels, so that its movement

forward may be accomplished in the least possible time and with the minimum of labor.

When thus shifted forward, a semi-circular stairway is placed around the base of the tower, hiding its mechanism and covering the electric cables leading to it for the lighting purposes. A large iron beam swings forward and locks the tower so that it cannot topple over or sway.

The tower itself is mounted on a large wheel supported by roller bearings. Two stairways lead upward in such a manner that one spirals to the left and the other to the right. The inner stairway is covered by very fine gauze, which makes it invisible ordinarily. The rotating mechanism of the tower consists of a worm-gear drive which is rotated by two men in back of the drop or back scene.

Now, for the effect! A stairway-like-wise collapsible, so that it may be moved out of the way when not in use—connects to the top of the tower, but the means of

approach to the tower is hidden; a sliding trap door communicating directly with a door in the tower. The chorus girls, hidden from view, suddenly are seen to descend on the outer spiral and arrange themselves in artistic, graceful groups upon the platform of the tower itself and the stage. After a short period of entertaining they are seen to ascend the spiral stairway to the top and seemingly to disappear, while in reality they descend again on the inner stairway. Suddenly, the lights illuminating the inner spiral are flashed on the tower, being made to revolve at the same time. This causes the girls behind the gauze-veiled inner stairway to be seen as tho in a mist. They descend constantly, while those on the outer are ascending, thanks to communicating platforms between the stairways at both top and bottom, so that an endless stream of actors and actresses form a spectacular and bewildering maze.

The illustration shows clearly the arrangement of the tower and its methods of communicating at the top and bottom chambers, likewise the carriage and the rotative means. The insert view shows the top dome with its sliding trap door and the communication means between the two stairways; likewise the beam holding the tower rigidly in place. Two steel cables clamped to this beam are tightened by means of turnbuckles acting, in this way, as braces and minimize any lateral swinging tendency which the tower and its beauties may experience.

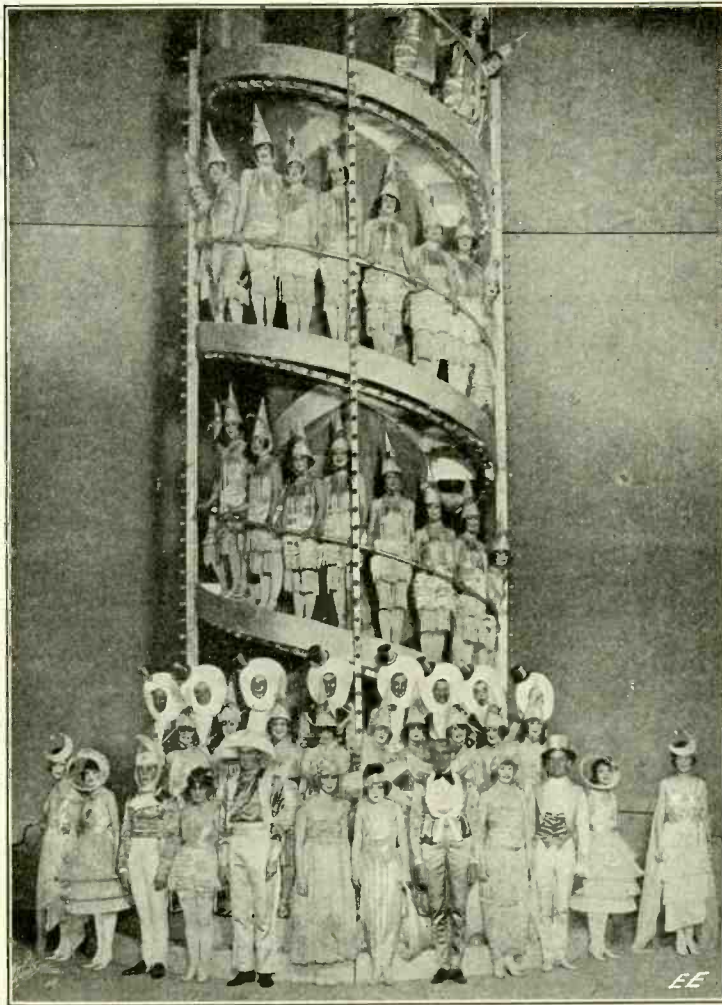

The Revolving Tower Filled with Chorus Girls from the Ned Wayburn Review at the Capitol Theater.

Immediately below the base are three commutators which supply current for the illumination of the tower. Large brushes make contact with the commutators, each of which is directly connected to a very heavy rubber covered cable, running to its supply base, the switchboard back stage.

The switchboard itself is a beautiful marvel of simplicity. It is capable of producing not only ordinary actual work, but intense serviceability under unusual conditions. Its panels of the unit type are constructed so that they may be removed separately for any necessary repairs. From this switchboard, a variety of current may be obtained and methods for inserting plugs to draw any voltage of any form from it are found to conform with both the fire underwriters' laws, and laws, if such there are, for preventing any serious accident to those directly responsible for the electrical side of the show as there is no way of coming in contact with a live circuit, all the switches being entirely concealed. From the switchboard, 110 volts alternating or direct current may be obtained. Likewise, 220 volts in both forms. Elaborate rheostats and regulators allow a gradation of current value which alone is capable of producing most wonderful stupendous effects which any stage setting or any play may necessitate.

Fourteen or more projectors with variable color filters enable a diffusion of light in all its color values to be directed in streams upon the stage and actors.

The Locomotive Periscope: Next!

By GEORGE WALL

NOW that the war has shown us what an invaluable instrument the modern periscope really is, even to the extent that thousands of our brave soldiers in the trenches in many instances owed their very lives to the efficiency of the trench periscope for looking over the parapet without exposing their heads or bodies, we are not surprised perhaps to see the periscope adapted to the requirements of modern railroading. Why not use the periscope on locomotives, both electric and steam? It should save many lives for more reasons than one. Its use should certainly prevent many heretofore unavoidable occurrences such as rear-end collisions, etc.

The periscope for locomotives employs a large mirror, so that the engineer need not focus his gaze accurately on a small eyepiece, as in the submarine periscope, for this would hardly do owing to the many duties constantly thrust upon him. The accompanying illustrations show the

periscope in use on an electric locomotive and two of them are here employed, as the electric locomotive, unlike its steam-driven prototype, is liable to run in either directions, for it is reversible.

For one thing, the locomotive periscope will enable the engineer to see at all times any signals from the rear of a long freight train, such as the swinging arm signals, or swinging lantern signals, given by brakemen atop the cars, and he also can see the track far to the rear. This means that if he should see a train on the same track

approaching at a dangerous speed, that he can speed up his own train, so as to minimize the effect of a rear-end collision, if such really is to occur at all.

We have often heard of railroad engineers racing their trains so that the runaway train on the same track behind, either cannot catch up with him, or else if it did, and in view of the fact that his own train was traveling at a speed approximating that of the pursuing train, that any collision between them would be very slight, compared to one that might occur between

the stationary or slow-moving train and the rapidly-moving train at the rear. No one can look in two directions at the same time ordinarily, but thanks to the locomotive periscope, the engineer of tomorrow will be better off so to speak, for after a little practice, he can keep a sight ahead as well as behind, by simply glancing periodically and regularly at the periscope beside him.

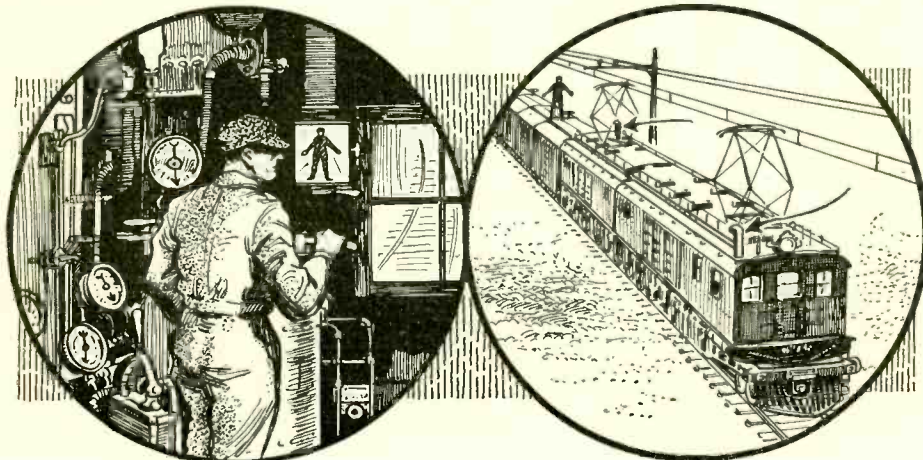

Abolishing Smoke Electrically

THE dust and fumes which are discharged from the stacks of iron furnaces, cement mills, and many other industrial enterprises, not only represent a waste of valuable material but also frequently constitute a nuisance. In the interests of economic con-

How Thousands of Dollars Are Reclaimed by Smelting Companies

ess. He need only stand where he can watch the stacks leading from the *treater*, while some one opens and closes the treating circuit. When the current is "off," the familiar clouds of smoke pour out; but when the current is "on," the smoke vanishes, and nothing but a fine vapor can

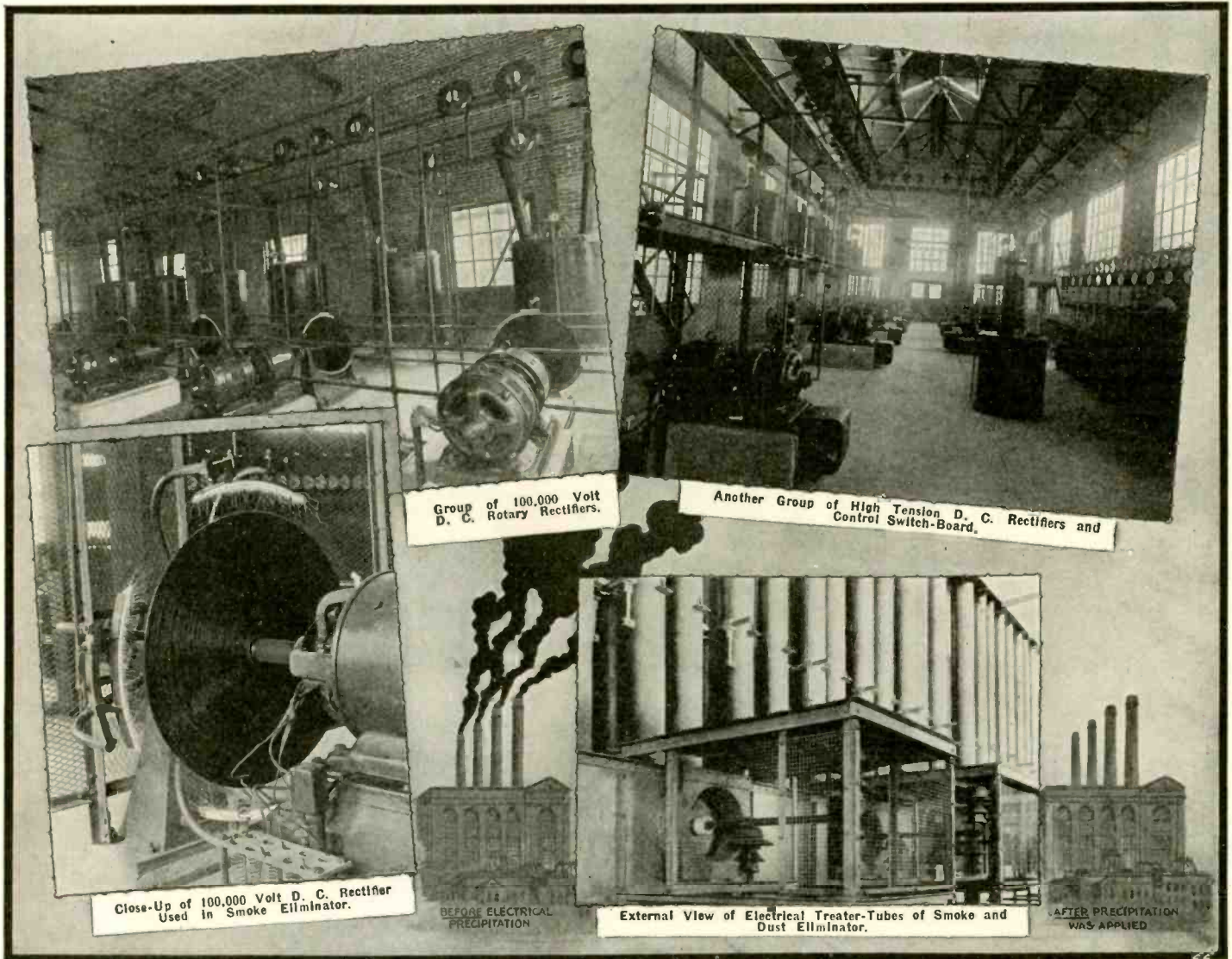

servation it is desirable to eliminate the loss of material represented by this dust, and for civic or legal reasons it is often necessary to suppress the nuisance caused by its discharge into the atmosphere. Such cities as Pittsburgh for instance have long been known for their smoky and objectionable atmosphere.

While there are several mechanical and chemical methods for collecting or suppressing dust in furnace and kiln operation, they are in general limited in application by conditions of temperature, acidity, and similar qualities of the product to be handled. Electrical precipitation has few limitations of this sort and is generally applicable for collecting suspended solid and liquid particles of every description, whether acid or alkaline, from gases of widely varying temperature. The electrical method is simple, economical and effective, and has been successfully operated in a great number of plants of various kinds.

A visitor to one of these plants is easily convinced of the practicability of the proc-

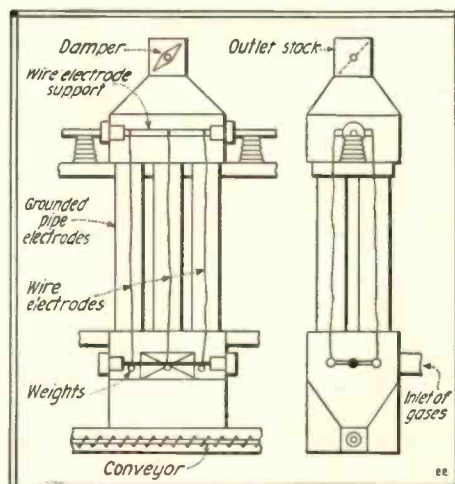

How Electrified wires are Suspended in Pipes Thru Which Dust Laden Gases Are Past

be seen. Final proof of the effectiveness of the operation is provided by the car-loads of precipitated dust taken out of the collecting bins.

USES OF ELECTRICAL PRECIPITATION

Electrical precipitation processes are now being used successfully in lead and copper smelters to reduce metal losses from the stacks and to eliminate smoke nuisances; in cement plants to collect potash and cement dust; in acid plants to recover acid fumes; and in rock crushers to suppress the dust nuisance. The process is also being applied to iron blast furnaces to eliminate the ore dust and to recover potash values; to gas plants for removing the dust, tar, and lamp black from the gases; to locomotive roundhouses and power plants, located in centers of population, to remove the soot and cinders from the smoke; and to industrial processes produc-

(Continued on page 931)

The Electrical Engineer at Work

By H. Winfield Secor

THE DAILY WORK OF THE ELECTRICAL ENGINEER

HOW does the electrical engineer work, and of what does his work consist?—is probably a question uppermost in the minds of not only embryo students of electrical engineering, but one which exists in the minds of parents of young men about to choose a career as well. Of course, it is impossible to describe the daily routine or the general work carried on by an engineer to fit any one type of engineer or class of work, as there are so many ramifications of the engineering profession today that it is hard to find two engineers engaged on identically the same work, or who accomplish their work in the same manner, in one engineering office.

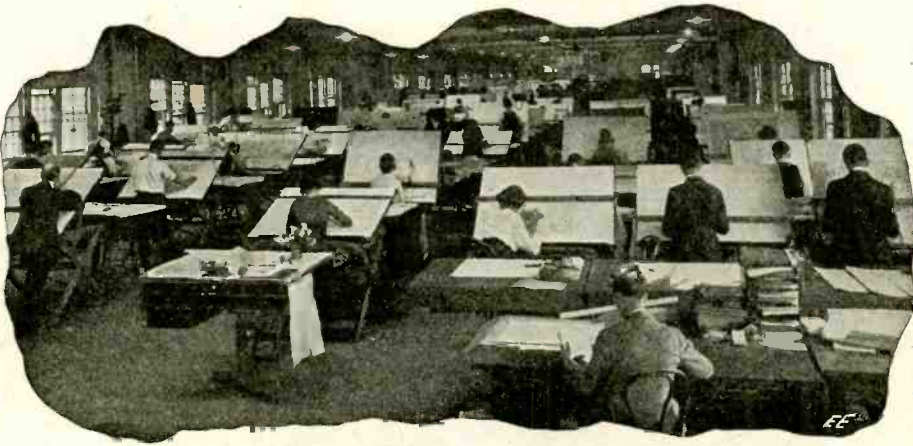

A Busy Scene In the Drafting Room of the General Electric Company's Works. Here the First Tangible Outlines of the Engineer's Ideas Are Brought to Life In the Form of Drawings and Blue-Prints.

catalogs, of which every engineering office has a complete file, in order to determine the dimensions of any stock parts such as wheels, pulleys, bearings, etc., which he may use in laying out the fundamental design of the first machine.

THE ENGINEER-DRAFTSMAN

The rough pencil or pen-and-ink sketches with a few notes on them covering the over-all design and "high lights" which come from the consulting engineer, reach the drafting room, and the chief draftsman, who is invariably a designing engineer of high responsibility and thoroughly experienced. Under the head of this Department comes a staff composed of what the layman generally knows as the "draftsmen" and "tracers." But once the

idea, he makes the first design from the idea as supplied by someone else in the organization or by a department of the organization, or again, possibly by a patron, who desires to have a certain machine built. Many times the outside patron simply has a hazy idea as to what he wishes to accomplish, but he is firm in his belief that it can be done—and it is, let us say, up to the consulting engineer who stands at the head of the engineering organization of his concern, to work out in his mind and develop the nucleus around which the future device or apparatus is to be built. The consulting engineer is invariably but not always, a college-trained man, and one who is a thoro mathematician. He is an expert with the slide rule and knows his text-books the same as a musician knows his notes and keys. In his early training he has wisely read all the books on the various subjects appertaining to his profession that he could possibly procure, and he has also providentially, in practically all cases, provided himself with a good working library of handbooks and text-books, which will be of real service to him. The carpenter, plumber or machinist works with his tools, and these tools he must have to accomplish any creditable performance of his work. The consulting or electrical engineer works from his hand-books and text-books, in general, coupled with his experience on various designs with which he has come in contact during his career. Right here we may advantageously study the mode of living, for that is really what it amounts to in the final analysis, of the thoroly trained engineer, no matter what line he happens to be engaged in. The carpenter for example, may build a house, or he may even design a building, but the writer has noted from personal experience, that very few carpenters or builders, who may erect such a complex structure, keep any data on the building as to its cost or the different dimensions for future reference, but the engineer, particularly the consulting engineer, will bend every effort conceivable to acquire all empirical data on any machine which he is interested in, and particularly, any machine or device that he has designed, and which has been built from his specifications. This should be so in every case, not only for the engineer; and as aforementioned, the engineer really lives his life in this fashion, and it does not hurt him either, for he grows to be methodical and exact without being taciturn or worrisome. Thus it is that the consulting expert refers to his books and also to

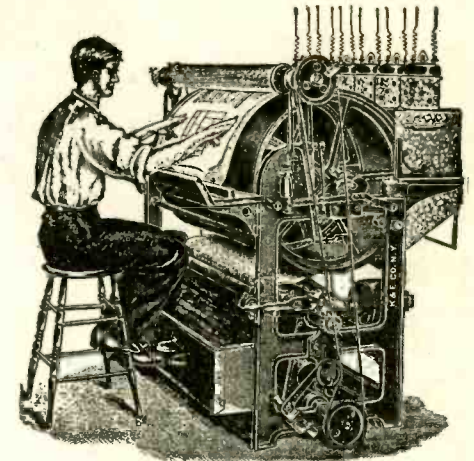

Blue-Printing by a Machine Fitted with Powerful Electric Lights Which Take the Place of Sunlight, Used in the Older Process. The Drawings Are Made on Tracing Cloth.

erstwhile layman has been initiated into the intricacies of the draftsman's everyday life, he will be surprised indeed, to learn what a mass of detail the draftsman, (Continued on page 955)

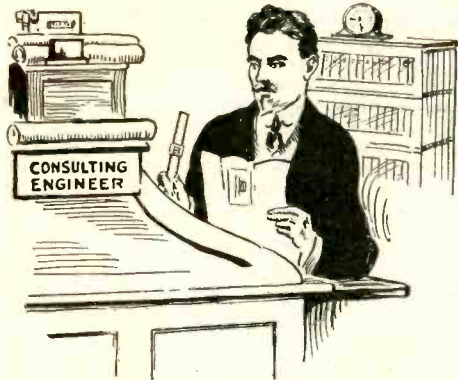

The Consulting Engineer—He Is the Man Who Must Understand the Technical Details of an Electrical and Mechanical Design. He Must Be a Good Mathematician.

Let us consider how the electrical engineer does his work in a typical case and under an organization such as exists in a large manufacturing plant.

THE CONSULTING ENGINEER

The consulting engineer is the man who either conceives the original idea from which a machine or device is to be built, or if he does not originally conceive the



The Draftsman, Whose Work Generally Laps Over Into the Engineering Line More or Less, So That When He Has Had Considerable Experience He Frequently Holds a Position as an Engineer-Draftsman.

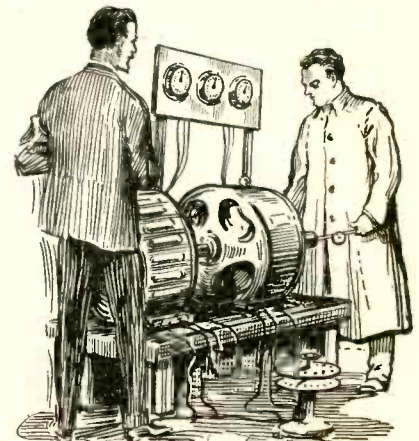

The Engineer Finds His Happiest Moments When the "Child of His Brain" Has Been Built and Made Ready for Test.

Science in Latest Movies

THE upper left and lower right photographs here reproduced are from the Pathé Serial—"The Third Eye." The villain in the photograph to the left is shown with a complete set of wireless instruments in the act of "sending," and the spark is shown leaping across the spark gap. This scene is in the cellar retreat of a gang of crooks whose radio apparatus is supposed to be used for communicating with the master criminal living in his palatial summer home on an island off the coast. He has just been ordered to start

across the gap the same as tho he were transmitting. Funny—no, we must allow the movies some freedom, and cannot keep them down to absolutely conventional means of connecting and operating such apparatus.

This play is a mystery story in about eighteen episodes, in which a man is murdered in a moving picture studio. The camera which has been focust to the point mysteriously starts to turn without any visible means and take some movies of the murderer. When the film is developed,

staff of a large New York newspaper. A girl had been murdered in New Jersey and he was sent out to get the dope and incidentally happened to be the first to make an examination. A short time prior to this he had read quite a little of the retina retaining an image of the scene or object it last saw, so he promptly photographed it on the murdered person. When the plate was developed, it actually showed an image, but the image was very imperfect and no definite indictment could be obtained on the image alone.

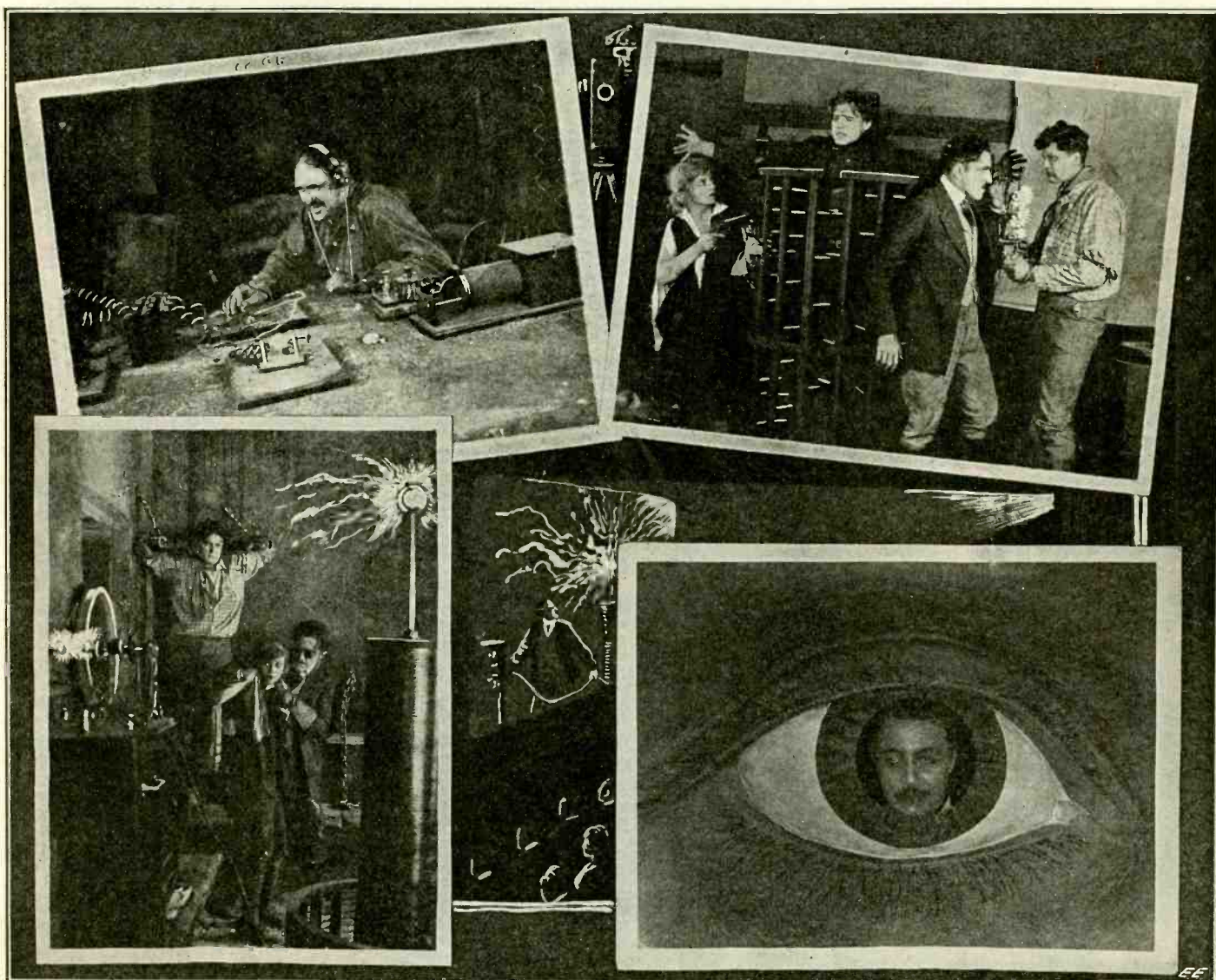

Villains In Order to Be Real (or Reel) Villainish Must Have Nifty Radio Sets. So In the Upper Left Photo They Have Given Him All Sorts of Diabolical Things to Play With, Blow Up Houses, Etc. In the Photograph at Its Right, Is the "Iron Maiden"—Electrified! "Now, Elleen (Lower Left) Don't Get Too Ticklish with the Oudin High Frequency." At the Lower Right, Is Nature's Photograph of a Movie Murderer, Permanently Incribed on the Retina of His Victim!??

sending a message, which latter will be received at another station and a spark will fly across the gap, as a result, igniting a can of dynamite and completely dismembering the anatomies of the hero and heroine. Of course in the "movies" the apparatus must be arranged so as to get the most pronounced effect, hence the massive coiled wire; which, if used in a modern wireless station, would be laughed at and ridiculed, as the impedance produced by the coils leading to the high tension condenser would cause unnecessary losses. To watch a movie man receiving a message, one sees the spark crashing

it is found that the hero is indicted for the murder, according to the "circumstantial evidence" produced by the developed film; but was he the murderer? Of course no hero could be.

In the lower right picture the author has made use of the theory that the retina of a dead man's eye retains for some time after death, an image of the last thing it saw in life.

In corroboration of this, Mr. Lewis, the publicity manager of Pathé films, cited a case of his own experience which occurred before he entered the "movie" game, at which time he was acting on the editorial

The lower left and upper right photographs are taken from the Universal feature—"The Great Radium Mystery"—in which a one-gram tube of radium valued at \$120,000 is actually being used. The entire play is based on the fact that a radium mine in Montana is discovered by two brothers and they had either mined or manufactured radium in such quantities that the whole manner of living and the history of the entire world would be changed at one single stroke, and new living conditions be thrust upon humanity over-night. Hence,

(Continued on page 961)

AMBRINE FOR ELECTRIC AND X-RAY BURNS.

Ambrine is the discovery of Dr. Barthe de Sandfort, a surgeon in the French navy. He believed, as most other surgeons believed, that open surface wounds should be treated with a dressing which would exclude all air and which could be removed without disturbing the newly formed epithelium. Ambrine is the wonderful preparation used with such success during the war to heal the burns from "liquid fire" attacks.

Ambrine is a neutral paraffin and resin compound, which is prepared according to a secret formula. On account of its organic composition, it is impossible to analyze.

The equipment comprises one fine varnish brush, or preferably a paraffin base atomizer; one double boiler; one electric drier; absorbent cotton divided into very thin layers.

When the patient enters the hospital, the clothing is removed; blebs are punctured, but not excised; and the entire area is thoroughly dried with an electric hot air drier, or a fan, so that there is no moisture on the surface (an electric fan or common fan may be used). The wax is applied to the burn at the earliest possible opportunity, either with a fine varnish brush or atomizer—preferably with an atomizer. It is difficult to regulate the temperature where the brush is used; it is more or less painful and

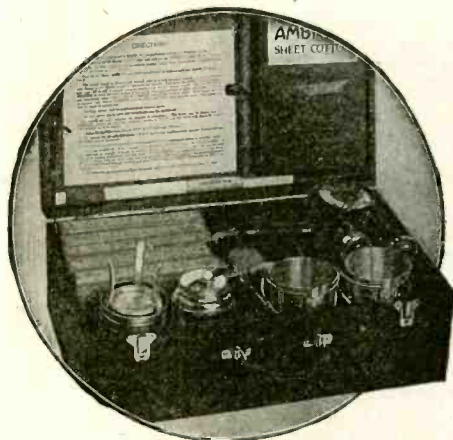

Electric Burns Are Among the Worst. Ambrine—the Wonderful New Wax Treatment For Burns Developed During the War, Has Been Very Useful and Healing in All Such Treatment. X-Ray Burns Can Be Treated By Ambrine Also.

there is a tendency to brush away and traumatize the new epithelium and granulations.

Chemical Burns. If the burn is acid, an alkali is used to neutralize the acid present; and if alkali, an acid is used; the burned area thoroughly dried and wax applied. In one case several acid burns, first and second degree, were treated in which 5 per cent. of the surface of the lower extremities was involved, which were cured and the patient in each case was discharged from the hospital in 11 to 12 days, with absolute freedom from pain during treatment.

X-ray Burns. Experience is too limited to express any opinion other than the relief from pain which the dressing assures. Dr. Mayo reports one case in which an excision had been done for a sluggish burn of more than one year's standing in which the granulating wound covered over satisfactorily with the wax treatment. It will probably have some value in the treatment of X-ray burns.

Electrical Burns. Holtze reports excellent results in the treatment of electrical burns (30 cases). Pain was relieved and patients recovered more rapidly than with other methods, with no contracting cicatricial tissue. He considers the method far superior to other methods and has standardized it in his service.

Astern! With Engine Running Ahead!

By CHARLES M. RIPLEY

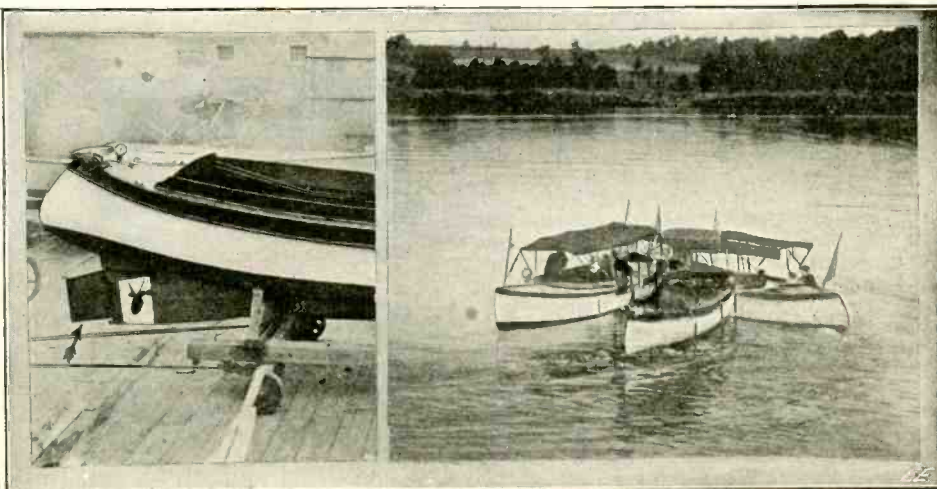

The Newest Thing in Boat Steering Devices—a Split Rudder, Which Permits of Running in Any Direction, Even Backward, with Propeller Turning for Ahead! Photo at Right—3 Exposures on 1 Plate, Showing Boat Turning in Its Own Length after Being Suddenly Stopt Short in Its Forward Course.

ONE of the large American electrical concerns has recently equipt a 25-ft. motor boat owned by Mr. W. B. Landreth, Deputy State Engineer of New York, with a simple yet remarkable reversing and control rudder, with a view to showing the possibility of eliminating reversing turbines from the large turbine propelled ships.

This boat is capable of backing up with the engine running in a forward direction, but the most valuable feature is its ability to turn around in its own length. With this rudder the boat can be maneuvered without steerage-way; that is, with the rudder placed at right angles to the axis of the keel and with engine running at full speed, the boat will stand perfectly still and then by making a slight adjustment of the rudders, the boat will turn around in its own length and continue to do so until the adjustment is changed; and during the process of this circular motion it can leave for any point of the compass at full speed.

As an illustration of the maneuvering qualities of the rudder, this boat was run into a 40-foot slip full speed ahead, turned around and came out bow first without touching either side of slip.

The rudder on the Landreth boat, the invention of H. O. Westendarp, of Boston, consists of two steel plates 3/16 of an inch

thick, each plate the same size as the normal rudder used on this type of boat. The rudder post consists of a steel rod inside a steel tube, one plate of the rudder is attached to the tube and the other to the rod. The boat is equipt with two steering wheels, arranged side by side, one wheel to operate the rudder affix to the tube, and the other the rudder fastened to the rod. The manner in which the rudders are affix to the stern of the boat is best shown in the side view herewith. This shows the two rudders close together in the position for normal cruising, when they are used the same as an ordinary rudder.

The two steering wheels, placed up forward in the launch, are on the same axis and when locked together operate as one wheel for ordinary cruising. But when the boat is to be turned sharply or reversed, the wheels are instantly unlocked and released, so that they may be revolved in opposite directions to manipulate the rudder plates.

It is truly remarkable how easily the boat can be made to turn within its own length. By placing the rudders in the position indicated in the diagram chart herewith the boat will turn around in a few seconds and travel back up its own wake.

(Continued on page 939)

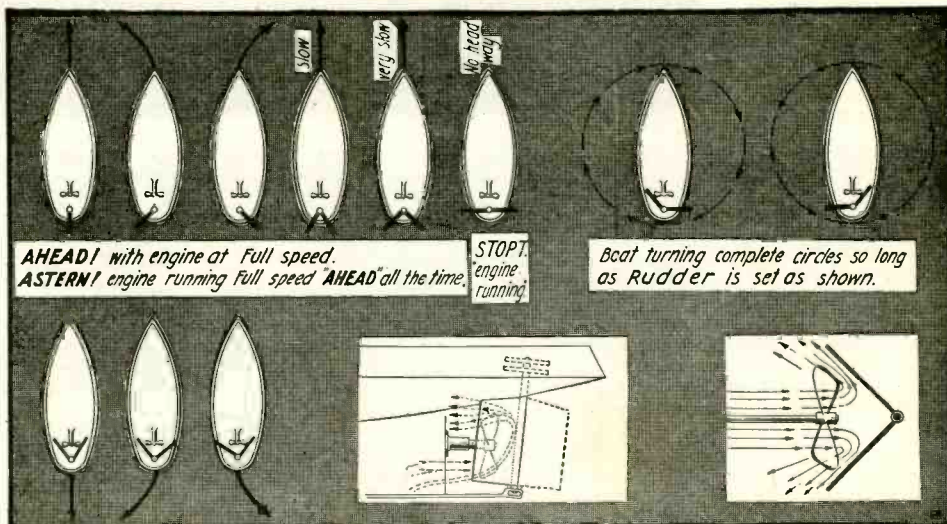

The New Compound or Double Pitch Steering Rudder by Means of Which a Boat Can Be Run Ahead, Astern, or in a Circle of Radius Equal to the Boat's Length, with the Engine and Propeller Running Full Speed Ahead at All Times.

The Mt. Wilson 100-Inch Reflecting Telescope

By FLOYD L. DARROW

Head of Science Department, Polytechnic Preparatory School, Brooklyn, N. Y.

HOW BIG TELESCOPES WORK

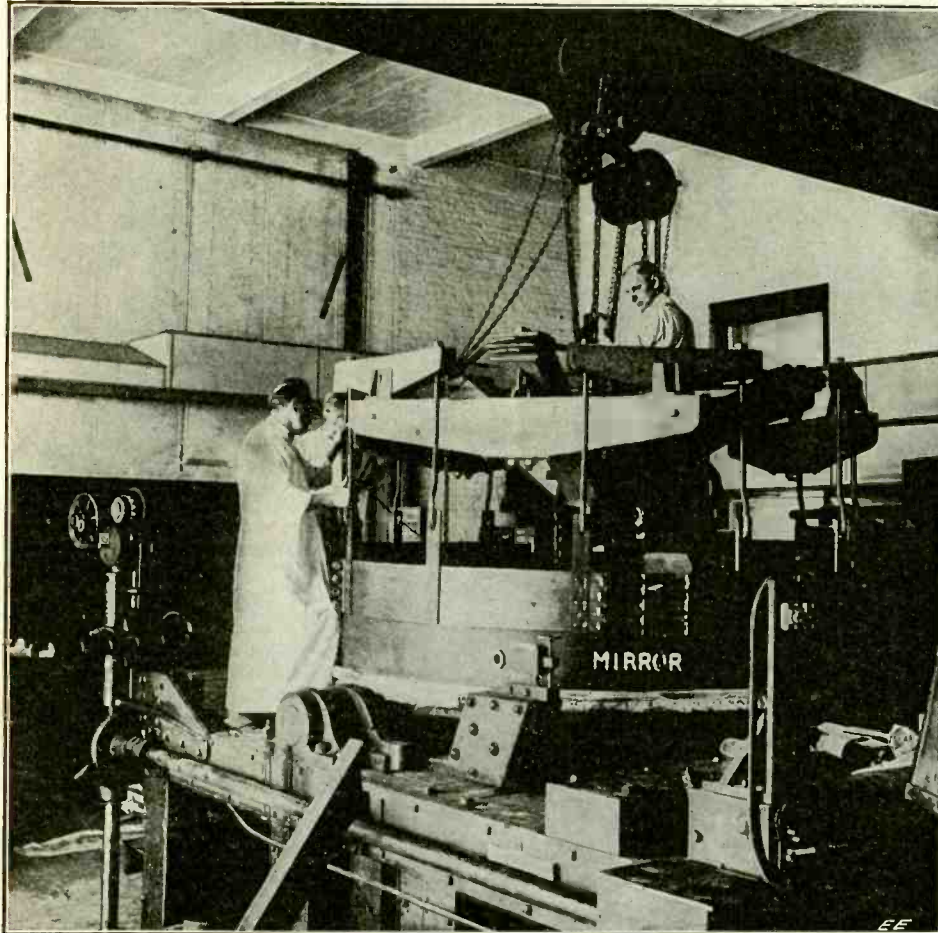

Lowering Clamp onto Huge 100-Inch Mt. Wilson Glass Reflector In Order to Lift It from Grinding Table.

NO other instrument upon which Man has applied his genius for invention has so broken down the barriers of space and loosed the fetters of intellectual bondage as has the telescope. From the days of Galileo and the crude "Optic Tube" with which he made those first epoch-making discoveries down to the giant 100-inch reflector just erected on Mount Wilson, California, stretches a continuous pathway of steady progress and brilliant achievement. As the novelist, H. G. Wells, says this planet receives no imports save meteors and has no exports whatever, yet these marvelous adaptations of optical glass bring to view other worlds without end, push heavenward the bounds of the known universe by billions of miles and enable us to weigh the planets and analyze the stars with mathematical precision and exactitude.

THE FIRST TELESCOPE

To whom belongs credit for the invention of the telescope has never been definitely settled. About 1590 a Dutch optician, Zacharius Jensen, arranged in a tube a combination of lenses with which he was able to magnify small objects. A few years later a fellow countryman, Johannes Lippershey, experimented with a similar set of lenses and made the discovery that a distant church steeple was brought much nearer by their aid. But certain it is that Galileo, the great Italian scientist of Padua and Florence, with no

knowledge of these discoveries, invented the first astronomical telescope in 1610.

Galileo's telescope was of the refracting type and an explanation of its operating principles will be given in a later article. There were certain very serious defects in these early refracting telescopes, however, and Sir Isaac Newton set about the invention of another type of telescope which should depend for its optical properties, not upon the refraction of light thru lenses, but upon its reflection from a highly polished concave mirror. His first telescope was a small affair but it greatly improved the definition of the image and eliminated the troublesome color-fringe always present about the images produced with refracting telescopes. Newton quickly followed it with a larger instrument and from that day until this the reflecting telescope has been a strong competitor for first place in telescopic achievement and astronomical discovery. The immense six-foot reflecting mirror made by Lord Rosse and now in the British Museum is a notable example of the last century.

WORLD'S LARGEST TELESCOPE AT MT. WILSON

The latest and largest telescope of the world has just been erected in the Solar Observatory of the Carnegie Institution, located on Mount Wilson near Pasadena, California. This optical marvel was made possible by a gift of \$45,000 to the Carnegie Institution by Mr. John A. Hooker of Los Angeles in 1906. Mr. Hooker specified that this money should be used for the purchase and grinding of a glass disc 100 inches in diameter and having a focal length of about 50 feet. As the making of optical glass was an unmastered art in this country previous to the Great War, the order was placed with a large firm at St. Gobain, France, in the autumn of 1906.

An order for so large a disc had never before been received and its casting taxed

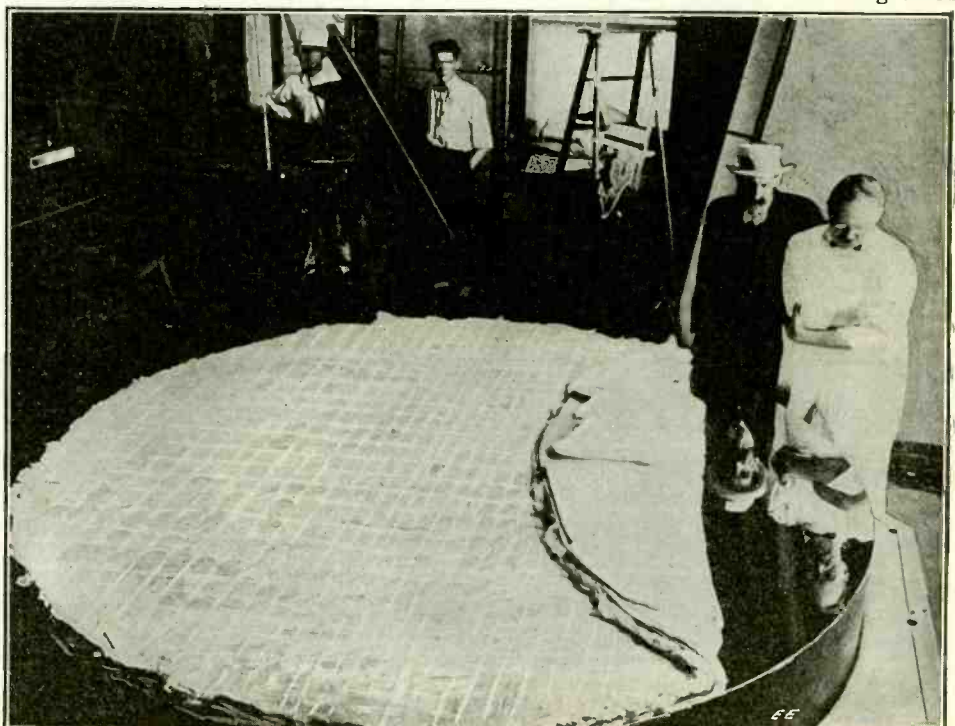

Note the Perfect Reflection of the Faces in the Polished Face of the 100-Inch Reflector Used at Mt. Wilson.

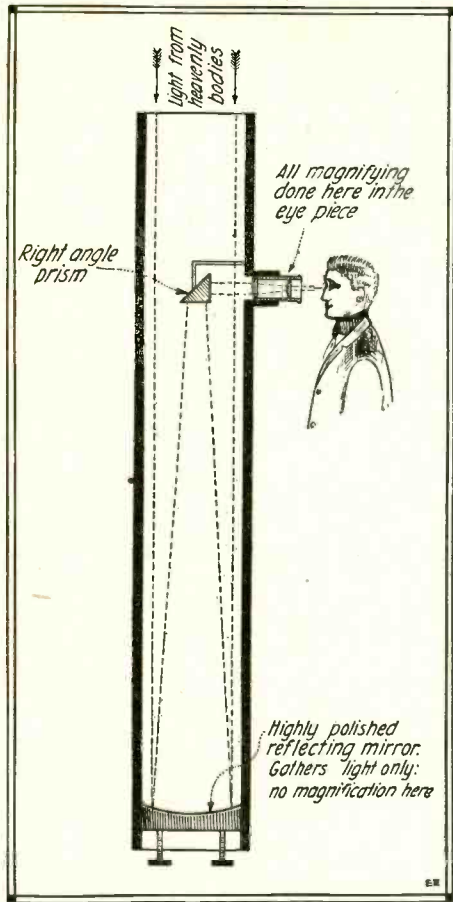

The "Newtonian" Telescope—Here the Image of the Heavenly Body Is Reflected from the Mirror at the Bottom, Up to the Prism and Lens Magnifying System Shown.

to the utmost the capacity of the plant and the skill of the master craftsmen who executed the work. After eight failures the disc was cast in 1908. It was packed just as it came from the mold and shipped directly to Galveston, Texas, by water and thence by rail to Pasadena. In the rough state the disc weighed 5½ tons, it was a little more than 101 inches in diameter and was 13 inches thick. A special building was erected for its grinding. But a close inspection of the disc revealed the fact that it had been cast in three layers and flaws were disclosed which seemed to render it unfit for optical use. Word was sent to St. Gobain and a new furnace capable of holding 20 tons of molten glass was erected. Two more attempts were made but neither

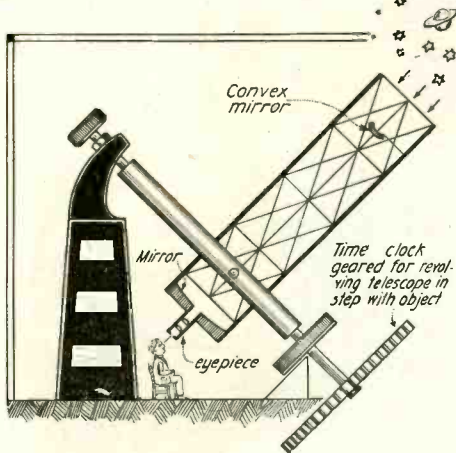

Diagram of the Mounting of 100-Inch Reflector at Mt. Wilson. Large Pedestal (North One) Bears 40 Tons, Small Pedestal (South) Bears 60 Tons. Large Wheel at Lower End of Polar Axis Is Toothed Wheel Engaging with the Clock Mechanism. Rectangular Yoke Is Shown Only in Side-View.

was as successful as the first. Prof. George W. Ritchey, of the observatory staff, and under whose direction the work of grinding was to be done then made a trip to France but found it a practical impossibility to cast so large a piece of glass at one pouring. Therefore the project of building the telescope must be abandoned or work must be begun on the original disc. Without hesitation the latter course was adopted.

THE GRINDING OF THE 100-INCH LENS STARTS

Not until 1910 was the disc placed on the grinding machine. The actual work was done by Messrs. Kinny and Dalton. The edge and surfaces were first ground off until the glass measured 101 inches in diameter and 13 inches in thickness. This was followed by the rough grinding of the concave surface. The grinding and subsequent polishing and figuring were done almost entirely by machinery. Very fine emery flour mixed with water and applied by wooden brushes covered with cheese cloth did the work of abrasion. No metal was allowed to touch the surface. The brushes revolved very slowly and from the center outward. This first grinding hollowed out the mirror to a depth of 1¼ inches and was followed by a second grinding in which still finer emery dust was employed and the utmost care was exercised.

Then came the polishing—a far more exacting task than the grinding and requiring a series of the most delicate and thoro tests. One difficulty early encountered was the discovery that the glass was astigmatic, i.e., the curvatures at right angles to each other were not uniform. Altho these curvatures differed by only .0016 of an inch, it was known that even this slight variation would produce serious distortion of images. For a time this baffling defect seemed likely to render the

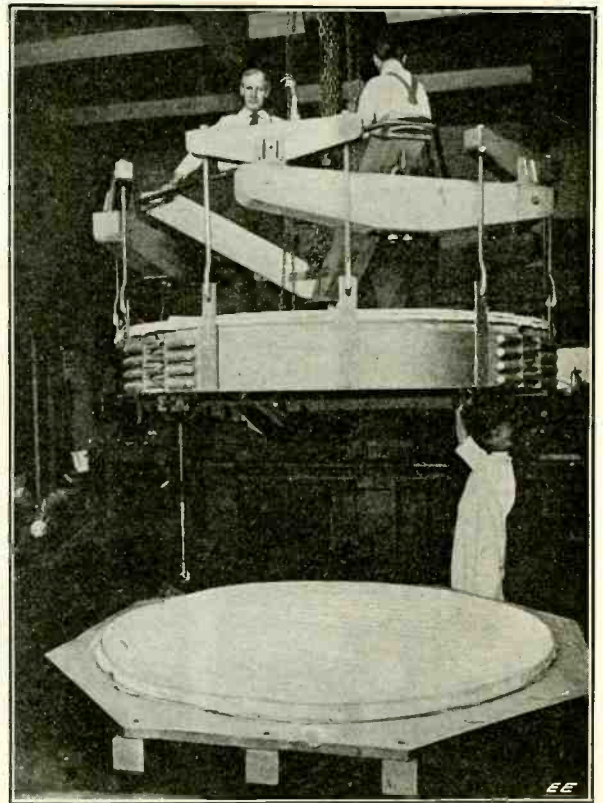

Lowering the Great 100-Inch Mirror Onto Cover, Preparatory to Transporting it to Summit of Mount Wilson.

glass unfit and to bring to naught long years of hope and painstaking labor. But a new kind of grinding tool devised for the purpose solved the problem. It consisted of a 1,500-pound plate of the same size as the glass, which exerted a uniform pressure at every point of the surface and thus smoothed out the inequalities of curvature.

One of the most important series of tests consisted in determining the effect of temperature changes on the qualities of the glass. It was subjected to variations ranging from 30 degrees to 105 degrees Fahr. and was found to suffer no harm if these changes were gradual. Rapid changes did

(Continued on page 942)

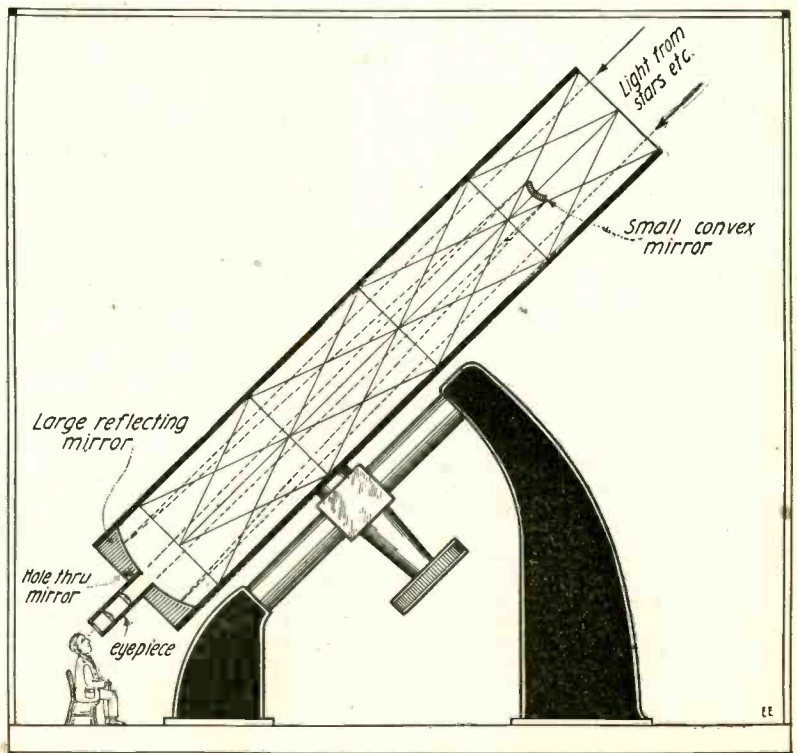

The Structure of Electricity

By Dr. Alfred Gradenwitz

IN the course of the last few decades our views regarding the nature of electricity have undergone great changes. Once upon a time a theory was generally held, according to which two imponderable fluids, a positive and a negative one, would by their shifting arrangement give rise to the electrical phenomena then known. Maxwell in England and Hertz in Germany, however, at the end of the last century introduced another theory according to which electrical and electromagnetical phenomena would be due

A Glance into the World of the Millionth Part of a Centimeter

Globules of such incredibly small dimensions are arranged between two parallel, horizontal plates connected to a positive and negative tension respectively and, accordingly, constituting an electrical condenser, the globules themselves being charged negatively. Each globule then is

individual atoms. Such particles, however, can neither be produced by crushing nor by stamping. According to the process suggested by Ehrenhaft they are produced by means of the very electricity the nature of which is to be ascertained, an electrical arc being made to pass between mercury, silver or gold electrodes, which are so intensely pulverized or evaporated that the intermediary space is filled up by a rain of particles some millionth parts of a centimeter in diameter.

If, now, the surroundings of these minute

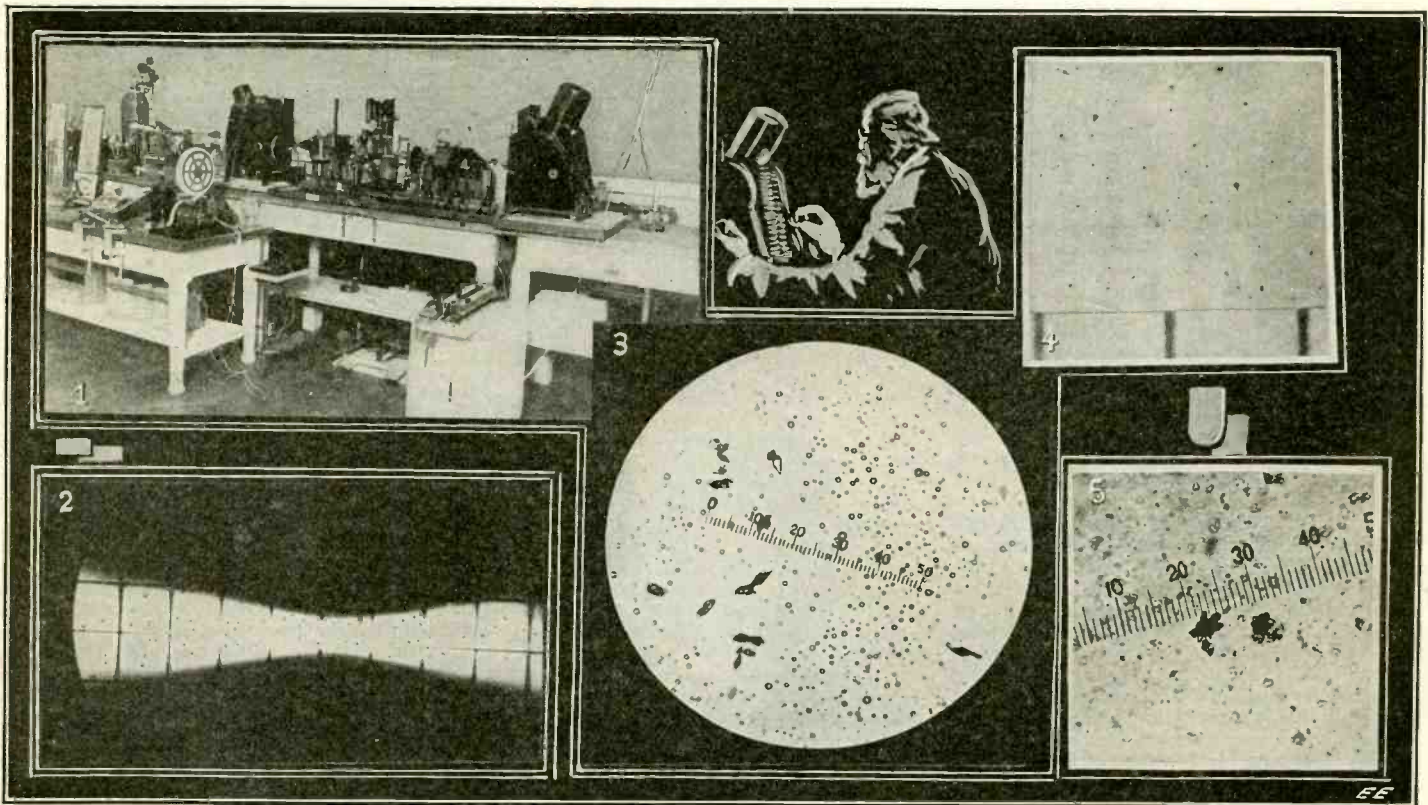

Fig. 1—Prof. Enrenhatt's Experimental Laboratory Apparatus Used In Examining the Structure of the Electron and Atomic Family. Fig. 2—Powerful Beam of Light Rendering Minute Particles Visible in Microscope. Fig. 3—Minute Sulfur Globules Mixed Up with Particles of Other Shapes. One Division of Ocular Scale 35.8×10^{-6} cm. Fig. 4—Minute Silver Globules Under 2870 Fold Magnification. One Division of Objective Scale: 1.10^{-6} cm. Fig. 5—Zinc Wool (Not Globular) Powder 1305 Fold Magnification. One Part of Scale: $11.5 \cdot 10^{-6}$ cm.

to ether waves of a similar nature to those of light.

More recently there has, however, been a general tendency for a revival of material conceptions on the nature of electricity. The same as matter is made up of indivisible small elements, *atoms*, electricity would consist of elementary quantas, *electrons*.

In opposition to this doctrine an Austrian scientist, Dr. Felix Ehrenhaft, Professor of Physics at the University of Vienna, however, already at the Königsberg Congress of Naturalists in 1910, drew attention to the fact that this would be minimum charge—the electron charge—though being ascertainable as average value, is inaccessible to human observation in the individual particles. In a paper recently read before the Austrian Society of Architects and Engineers, he exposes his further researches on the same subject, which not only give an insight into the very structure of electricity, but at the same time into the physics of minute particles—of the order of the millionth part of a centimeter.

by its weight drawn downward, while the electrical tension acting on its charge is pulling it in an upward direction. If, now, the condenser be connected to a tension just sufficing to draw the globule slowly towards the upper plate, the upward pull, which is dependent on the charge of the globule and the tension applied, will exceed the weight of the globule. The tension applied is afterwards reduced by degrees, until the globule just falls downwards in a vertical direction, thus confining the tension between two boundary values, the rising and falling tension, respectively. Inasmuch as these tensions are read off from a sensitive voltmeter, the charge of the globule thus is ascertained with the same accuracy as its weight.

In order now to obtain globules as small, and accordingly charges as minute as possible, it would be best to cause individual atoms to float in the interval between the condenser plates. This, however, is unfeasible, atoms being invisible even to the most perfect optical instruments. In fact, the smallest particles ascertained by means of our best optical instruments have diameters about a hundred times greater than

metal globules be lighted up with an intense beam of light, a microscope pointed vertically to the beam will disclose a sight comparable to a firmament of surprising splendor and variety of colors; each single luminous point falling, under the influence of gravity, in vertical trajectories, the stronger ones more rapidly, the weaker ones more slowly. The falling speed of all of them is, under the microscope, accurately measurable. Furthermore, each of these minute particles will, under some mysterious impulse, perform vibrations and move to and fro on zigzag lines. These Brownian movements, so far known only in liquids, are due to the nearly molecular dimensions of the particles in question.

These metal globules having been charged with variable amounts of electricity, Prof. Ehrenhaft each time—in accordance with the above—determines the tension at which a rising or falling respectively can be observed in the microscope. He therefrom ascertains the actual charge, the size—or weight—of the particles being known. Apart from the mechanical method—by means of the speed of falling—this weight

(Continued on page 961)

How Does Submerged Lady Breathe?

This clever invention, or rather illusion, apparatus is particularly intended to mystify and afford entertainment. By means of this device the performer, let us say, a lady, appears to observers to be totally submerged and to live and breathe in the water, the same as in the air, even to eating, drinking and smoking.

The illustration shows how this trick is performed. A watertight compartment is placed at the top of the structure, while the whole affair is housed in a covering either with cloth or other suitable material. Several water-lilies or other flowers should be arranged in the manner illustrated, one-half of the lilies, for instance, being rigidly mounted inside the glass-bottom water tank, while the lower and large part of the stem is placed in the compartment to be occupied by the performer under the glass bottom of the water tank, but in exact alignment with the upper portion of the plant. In this way it is impossible for an observer looking down from above to see any break in the stem of the plant, particularly when the surface of the water is ruffled, as for instance may be occasioned by allowing the water from the supply pipe to drip slowly into the tank at the top, or else by providing a slight draft of air from a hidden pipe, the stream of air being blown over the top of the water so as to create ripples.

It goes without saying, of course, that the performer, whether lady or gent, has to enter the chamber underneath the water

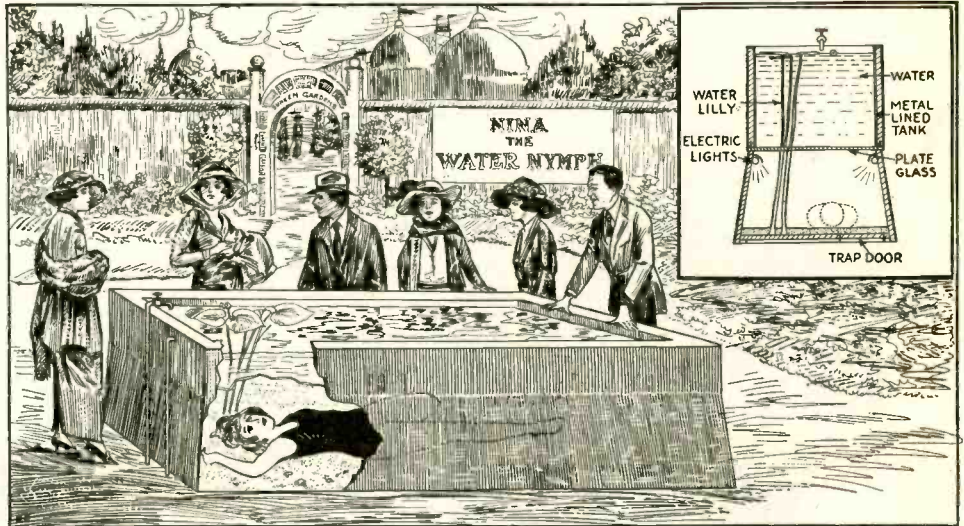

How Does the Lady Under the Water Breathe? It Proves Very Mysterious to the Uninitiated. The Answer Is—She Is Not in the Water, But in a False Compartment Below the Glass Bottom of the Water Tank.

tank unknown to the observers or audience. This trick can be shown on the regular stage by means of a large mirror or series of mirrors placed just back and above the tank so that the audience can see the movements of the performer, who is

apparently submerged in the water constantly. In this case the lights can be turned on and then off in the opening and closing presentation of the illusion, or the curtain may be raised and dropt at the opening and closing of the performance.

A Novel German Trench Light

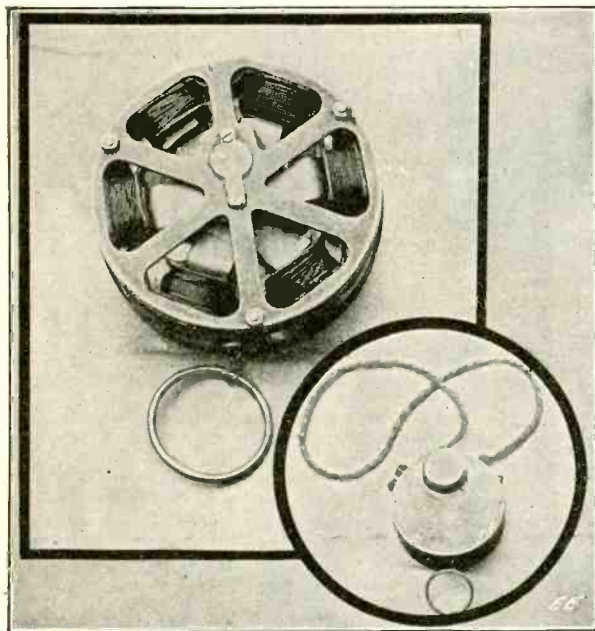

The accompanying illustrations show an ingenious design of dynamo-electric trench light which was captured from a Boche by an American doughboy. As will be recollected it was very difficult and in fact impossible to secure the many necessary materials in Germany during the war, to manufacture the hundreds of thousands of dry cells required by the Teutonic army and navy. The electric flashlight was one of the most used devices in the lines. The Germans, however, were not so fortunate, at least in the latter part of the war, and so it was that we find this interesting relic of the Teuton military regime in the form of a dynamo excited flashlight.

To obtain a light with this device which was built so as to withstand heavy wear such as is encountered on the battlefield, you simply pull the chain, the lower end of which can be

The "Heinles" Ran Out of Flashlight Batteries and Materials As Well As Their Breath, and Here We See the Consequence—a "Dynamo" Flashlight. A Pull on the Chain Ring and the Dynamo Was Spun Rapidly, Generating Sufficient Current to Light the Five-Volt Bulb. A Lens Was Fitted Over the Lamp Bulb.

seen in one of the photos, and to which a finger ring is attached. The propelling chain on this generator was about 14 inches long, having a gear inside of the dynamo casing, arranged to co-act with a ratchet in such a manner that the six legs of the permanent steel-magnet armature were spun around repeatedly in one direction. The details of this clutch mechanism are shown in one of the illustrations, and it is very clever in its design. The rotor is composed of three U-shaped steel magnets, as shown in the drawing, and the three magnets are clamped together to form an armature or really a rotating field. The stationary coils of which there were six, were wound with fairly heavy copper magnet wire, about No. 24 B. & S. gage. These are connected in series alternately, in the usual fashion, so as to give north and south polarity successively.

The casing of the flashlight is finished with a substantial oxid effect, so as to withstand the weather while a braided cord attaches to two rings on the casing, so that it can be suspended from the neck of the user while he pulls on the generator ring as he walks along. The lamp throws a good beam of light, the bulb itself being a small screw-base type, fitted in a reflector with a lens in front of it. The dynamo generates a low voltage, equivalent to a few cells of battery, and the current is surprisingly steady—almost flickerless in fact, when the generator chain is pulled in a fairly rapid manner.

There are several American concerns developing a magneto light of this type—i.e., one in which a small dynamo is rapidly spun by hand or finger action to produce electricity for lighting the lamp, instead of depending on a battery for the purpose. The problem appears very simple, but apparently is not as easy to solve as would at first appear, especially in a small lamp.

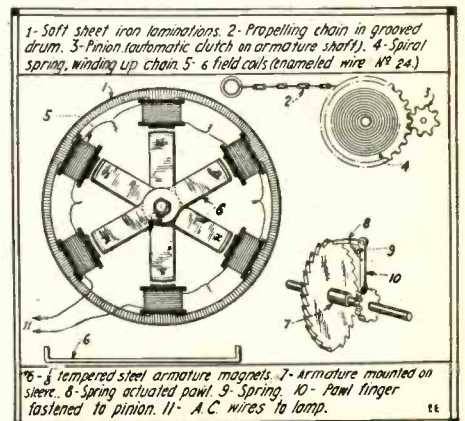

The Interior Mechanism of the German Trench Light, Showing How the Dynamo Armature Was Arranged To Be Spun By a Chain and Drum Clutch.

The Amateur Magician

By JOSEPH H. KRAUS,

THE MAGIC "FIRE-BOWL"

A SHORT time after I stepped off the train, I arrived at the pretty Long Island home of Professor Henri Hargrave, the noted magician. The servant admitted me a few moments later, and ushered me into the professor's study, requesting that I make myself at home. Somehow or other I never was able to do this when there are surroundings of the same nature as those at the Hargrave estate, consequently the servant's invitation was, I am afraid, superfluous.

The spacious study filled with weird, mysterious objects was now under scrutiny, each piece of workmanship was critically examined. While thus engaged the Professor entered, just as I turned to meet him.

"Well, well, how are you?" he exclaimed, presenting his hand in a hearty shake. "Have a chair, have a cigar, have a— What can I do for you?"

These questions were fired at me so quickly, I stood there wondering which one to answer, and while still pondering, altho for only a short time, Professor Hargrave thrust one of the cigars between my teeth, eliminating the necessity of answering his inquiries.

After a few puffs on his cigar, he rose to his feet and said, "Well, 'Old Timer'—what shall we give them this time? Will the 'fire-bowl' do?"

I nodded in the affirmative. "Don't shake your head, because I can't hear it rattle," he added jocularly, repairing to the back of the study. A few moments later he stepped forward



Making Fire While You Wait and So Simple That Anyone Can Do It. Read on MacDuff, Read On.

While thus engaged with his little epigram, he lifted a cover from the table nearby and placing it on the bowl, extinguished the mass of flaming gases. Removing the cover again with the same speed which characterized all his motions I beheld the same bowl, which only a moment before was belching forth streams of fire, full of flowers of all hues and shapes!



Note How the "Fire-Bowl" Is Suspended from the Belt. It's Great to Have a Little Heat Under the Belt in These Days of "Prohib.," and Just Imagine!—"Real Alcohol" Is Used as Fuel.

Placing the bowl upon the table and drawing his chair alongside of mine, he said, "Do you think that will do?" and seeing that no reply was forthcoming, he added, "I think so. But what's the matter with your 'weed,' is it out again?"

This, in reference to my cigar which I had forgotten about during the performance. Lighting up both our cigars, he continued with his discourse.

"I think that the best way that I can explain the trick is to show you how it is done, and then you will be more able to grasp the meaning of the various parts and their relation to each other, together with their proper functioning."

Reaching for the bowl on the table he hung it from his vest under his coat in such a position that it covered the lower left vest pocket—then secured the cloth. Waving it in such a manner that one is convinced that there is nothing on either side, he slung it over one arm, covering, in this way the movement of the other hand in its journey to the bowl. This time it was quite apparent that the bowl did not come from mid-air as it seemed to do originally; but the clever manipulations which the performer executed could only have been gained thru practice.

"You see," he exclaimed, removing the bowl from the table, upon which he had replaced it, and handing it to me, "The bowl is suspended from this little hook on the edge, from the performer's belt, and held in a vertical position, being covered by his coat. In its center you will note a small hollow saucer-like affair, which communicates directly with a long tube. This tube slopes a trifle so as to allow its contents to

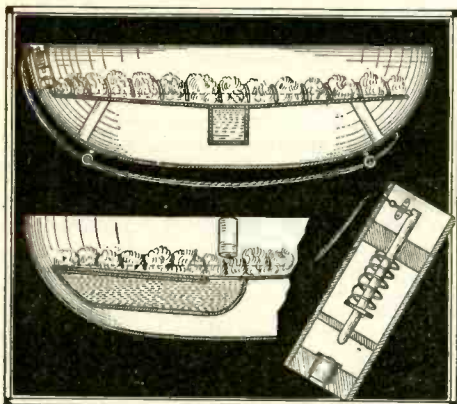

The Above Drawing Depicts the Construction of the "Fire-Bowl." The Tube Containing Alcohol Is Seen Slightly Inclined, Likewise, the Position of the Pistol-Like Device for Setting Off the Inflammable Mass. Slight Pressure on the String Is Sufficient to Cause the Mass to Burn, Its Flames Reaching to a Height of Four Feet.

waving a large red cloth in his hands. Showing both sides of this repeatedly, he suddenly produced from its folds a nickel plated bowl, from which poured forth streamers of fire which licked the ceiling.

"You will note that there is very little 'gift of gab' necessary for this trick. It depends more on the result than on the ability to talk. I've performed this same stunt before all the crowned heads of India, the big heads of America and the bone-heads of Germany, and it never fails to produce an effect short of miraculous."

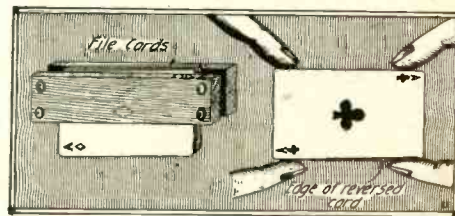

Method of Making a Deck of Cards Which You Should Never Use in a Poker Game Unless You Care Nothing for Your Life. The Cards Clamped in a Wooden Vise Are Shaved Down at One End, Whence by Simply Reversing Any Card It May Instantly Be With-drawn from the Deck, the Fingers Being Placed as Shown.

leak out when the bowl is placed on a level keel. The tube is of course filled with alcohol or some other inflammable material, in an upright position, whence it acts much the same as a bottle with its cork removed.

"Gently sloping toward the central tube receptacle is a round sheet of asbestos, covered with a layer of absorbent cotton fastened in place by wire, and sewed onto the asbestos. The asbestos sheet holds its position by virtue of several sheet iron legs, which are fastened to the bowl with ordinary solder.

"So much for the bowl and its reservoir. Now we come to the method of igniting the inflammable mass. This consists of a simple holder which will take an

(Continued on page 925)

Practical Chemical Experiments

By ALBERT W. WILSDON

HEATING THE HOUSE

At the outset the writer wants to impress upon the reader that he is not aiming to pass upon the merits of the various commercial heating systems now in use, but merely intends to give data on some of the systems and fuels as used for heating in certain

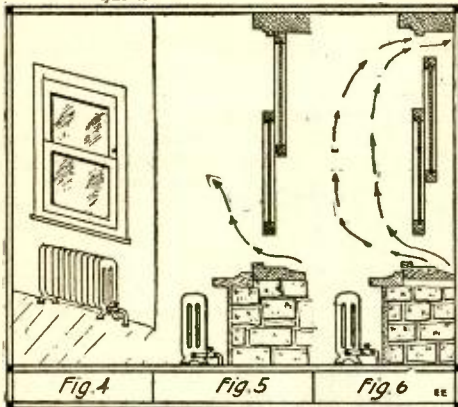

Fig. 4—Like Fig. 1, When a Room is Heated with the Windows Closed Both Top and Bottom the Highest Efficiency of the Heating System is Not Obtained, to Say Nothing of the Consumption of Unnecessary Fuel. While the Results are Not So Vivid as in the Case Where a Candle is Burned as in Fig. 1, the Principle is the Same and the Heating System Will Fall to Work Satisfactorily if Provision is Not Made for the Escape of Foul Air from a Room, as the Fresh Air Will Not Continue to Flow In Unless an Equal Amount Escapes.

Fig. 5—A Fair Method of Ventilation with Radiator by Window, But Not the Best. Fig. 6—Here a Circulation of Air is Maintained Constantly, with the Window Open Top and Bottom.

localities that demand certain heating substances be used on account of the facilities at hand to obtain them.

There are at present four extensively used substances employed for heating: 1, Coal; 2, Oil; 3, Gas; and 4, Electricity; and these will be taken up under the various systems utilizing them. Conveniences and disadvantages enter into the question of selecting either of these. In houses coal apparently holds its own as a favorite, probably because once lighted and with proper attention the fires may be kept in for considerable periods of time, and also on account of the number of rooms which may be heated by means of radiators or heated air systems.

Ventilation is as important a factor in heating rooms as the actual heating itself, and mention of this will be referred to thruout this article with practical laboratory experiments.

There are three common methods of heating, i. e., by means of 1, direct radiation; 2, indirect radiation; 3, direct-indirect radiation.

Direct Radiation. Under this heading may be included the open fireplace, stoves or else by pipes or radiators carrying steam or hot water. The open fireplace is not an economical method of heating, because it wastes from 75 to 95 per cent. of the fuel. This form was utilized before boilers and furnaces were introduced and are now used in regions where the supply of wood is abundant and coal or other mediums non-accessible. When heating by means of a stove, air being essential for combustion of fuel, it is thus removed from the room thru the chimney; consequently an equal amount of fresh air must enter the room to make up for that lost. When using a stove, it should be large enough to thoroly heat the room, even in the most severe cold weather, without running at its fullest heating capacity. It is false economy to heat a room with a small radiating sur-

face on account of the air of the room that is in contact with this surface becoming overheated. Stoves largely heat a room by convection, that is, by heating the air that is directly in contact with the stove, and when this becomes heated it rises and gives way to the colder air.

There are openings or draft slides and dampers on the stove which perform special functions and few people bother themselves to find out their uses, being content with merely adding coal as the fires need it, not thinking of the waste of fuel caused in this manner. The openings at the bottom of the stove should be so arranged as to completely shut out the air if necessary, thereby controlling the fire. This method is much safer than the practise of shutting the damper in the pipe as this will drive the products of combustion into the room, which if it occurred during the night, and more particularly if the wind abates, would cause to be liberated the dangerous sulphur dioxide, carbon monoxide and the suffocating carbon dioxide to the detriment of

ing effect and may cause the furniture and woodwork in the rooms to crack and split. By evaporating water in the hot air passages the dryness of the air may be reduced.

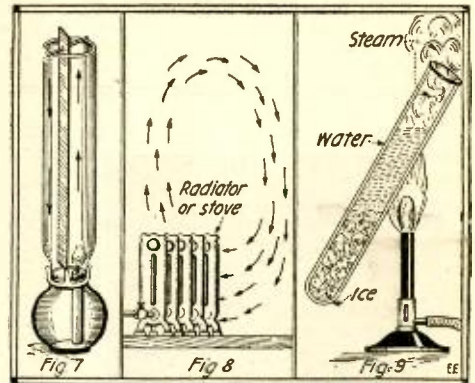

Fig. 7—Let Us Place a Partition in a Chimney with the Bottom Closed as in Fig. 1; the Candle Will Continue to Burn, for Now the Cool Air (More Dense) Flows Down on One Side of the Partition and Pushes the Warm Air Up the Other.

Fig. 8—Illustrating a Familiar Example of Heating by Convection and of Convection Currents in Air. For Laboratory Experiment See Fig. 9.

Fig. 9—Let Us Place Some Pieces of Ice in a Test Tube Fastening Them There with a Coil of Wire and Pour in Water Till the Tube is Nearly Full, and Then Hold It Over a Burner So That the Heat Will Be Applied At a Point Covered by the Water and We Will Show That the Water Above the Ice May Be Boiled, While There is Ice Only a Short Distance Below.

New Chemistry Series

The publishers have great pleasure in announcing that they have arranged for a new series of EXPERIMENTAL CHEMISTRY papers, to be prepared by Prof. Floyd L. Darrow, Instructor in Chemistry and Physics at The Polytechnic Preparatory Country Day School, Brooklyn, N. Y. Prof. Darrow is the author of numerous articles and books on the subjects of Chemistry and Physics, and possesses a clear and very interesting style of writing on these topics, which we feel sure our readers will find a real treat.

the occupants. It should be borne in mind that when insufficient air is admitted below the fire, more carbon monoxide will result, and the full heating value of the fuel will not be obtained.

Indirect Radiation. The ordinary hot air furnace represents this form of heating. By this means the air to be circulated is admitted thru a duct from the outside of the building and passes over the heated surface of the iron and is then distributed thru pipes to the rooms. Owing to the fact that the warm expanded air leaving a register can hold much more moisture than the cooler denser air that entered the heating passages of the furnace, it has a dry-

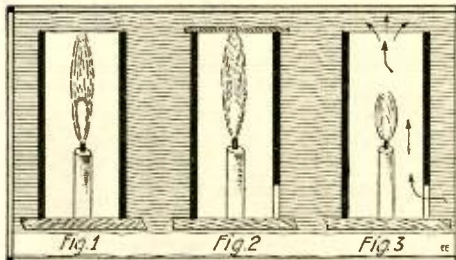

Fig. 1—By Placing a Candle in an Ordinary Lamp Chimney Open at the Top and Fitting Close to the Table at the Bottom It Will Be Found That the Candle Will Soon Stop Burning. This Illustrates That the Fresh Cool Air Will Not Enter Freely at the Top. Fig. 2—If We Now Take a Chimney Closed at the Top and Open at the Bottom and Once More Introduce the Burning Candle, the Candle Will Again Go Out, Illustrating That the Warm Air Within Prevents the Fresh Air from Entering.

Fig. 3—If We Now Take a Chimney Which is Open at Both Top and Bottom It Will Continue to Burn. The Cool Air Will enter Below and Drive the Warm (Less Dense) Air Out.

In the use of Steam with indirect radiation it is convenient to have steam coils in the lower part of the building so situated that fresh air can pass over them, and then by means of suitable flues into the rooms above. Once more it is essential that some provision be made to keep the incoming air moist, and this may be accomplished by placing pans of water upon the steam coils or radiators. If direct radiation is used, one disadvantage of this system of heating is that the air in the room is dry.

Water is used for heating on account of its great capacity for retaining heat. The hot water can be carried thru the pipes to some distance from the boiler, give up its heat and then be returned by means of another series of pipes to the boiler.

The Hot Water System has this advantage over steam that as soon as the water is warm enough to circulate it begins to warm the room and the heat is retained for a long time after the fire has been allowed to die down. In the case of steam there is no heat from the radiator till the water in the boiler is above the boiling point. With the use of hot water the temperature of the radiator is never above 100° C. and usually much below this, and with a suitable surface for evaporating water in the rooms the air will be very agreeable. As the temperature of the radiating surface is lower than in the case of steam, the heating surface must be much larger and consequently the cost of installation is greater than the steam system.

In the direct-indirect method of heating air is brought from the outside either behind or below a steam or hot water radiator standing in the room, and is heated in its passage over the radiator. This is also theoretically very satisfactory, as excellent ventilation is secured, tho not often attempted on a large scale.

In order to secure good ventilation the fresh air introduced into the room must be ample in volume. It must be free from contamination with dust and germs.

THE CONSTRUCTOR

Home-Made Arc Searchlight

By FRANK CALVERT, Jr.



At Right—the Constructional Details for Building a Home-Made Arc Searchlight of 1,000 to 1,200 C. P. It is Operable on 110 Volts D. C. or A. C. Above—the Arc in Operation, With Rear Door Open.

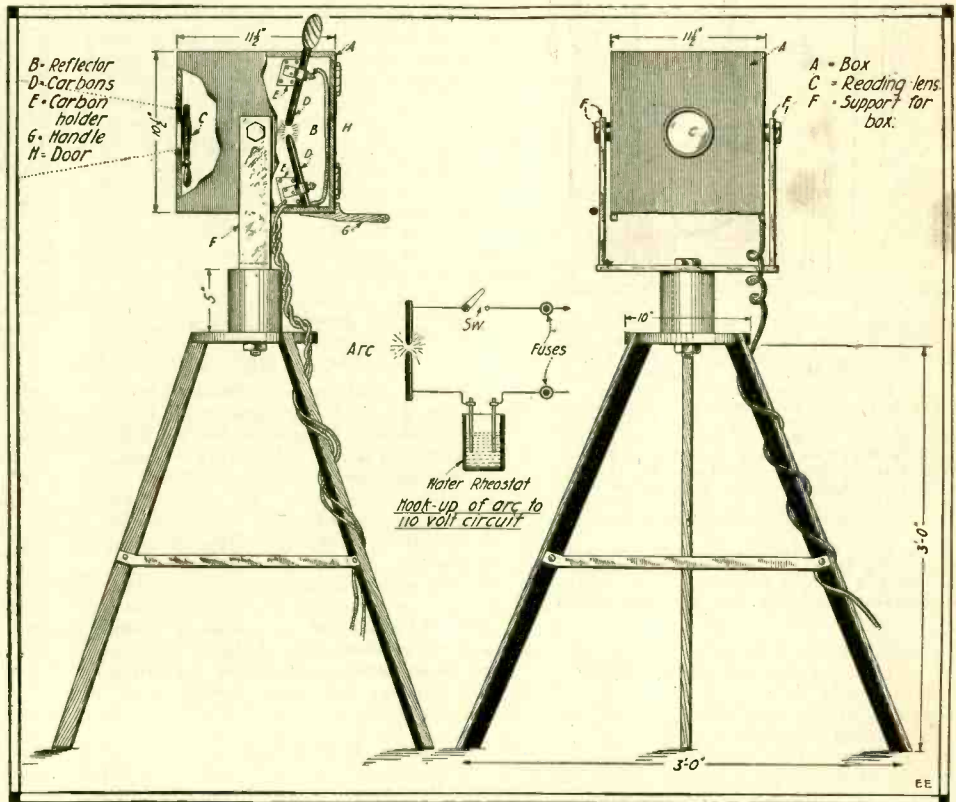

I PRESENT herewith plans of an arc type searchlight which I have just built, and I hope fellow experimenters will be able to make use of them.

The search-light is crude but will prove very interesting. It is easily built. It is connected with 110 volts, in series with a suitable resistance. We used a tin can filled with salt water, having two elec-

trodes immersed in the solution thus made. The box was lined with asbestos. The carbons are fastened to the blocks with strips of tin. The bottom carbon being stationary and the top one loose enough to permit adjustment. The lens was an old reading glass.

We found that by moving the carbons backwards or forwards the beam can be

made smaller or larger. The addition of a door at the back of the box makes it easier to handle the arc. The search-light can be built of pine and the principal dimensions are given in the plans.

I am enclosing a photo which was taken at night-time with the door slightly open. This light will prove highly interesting.

Electric Gas Stove Lighter

I believe every experimenter should be able to construct this electric gas stove lighter, as it is very simple to make, being made of old or discarded parts of a telephone, a spark coil from an auto, a carved hard rubber or Bakelite handle to replace the receiver, which with a sharp knife and sand-paper can be readily made, two dry cells, and a box of the dimensions given in the drawing, to contain the above mentioned articles.

A suitable one-half inch spark coil can be obtained from an old auto, or probably your friend or the local garage has one which can be obtained for the asking. The receiver hook can be taken from any old telephone. There are always three contacts on the hook, but that will not interfere as long as only two are used. The

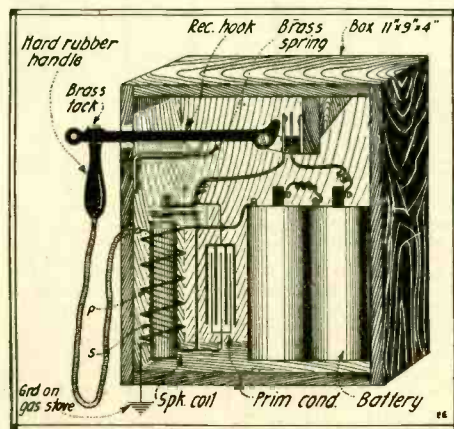

A Useful Gas Stove Igniter.

box can be made of 1/2" white pine and a hinged door attached so that the inside can be accessible at all times.

The handle "H" in the drawing, should be at least 1/2" thick surrounding the wire inside, where the hand grasps it so as to insure safety against a shock while operating it. A hole large enough for the wire to slide thru, should be bored the entire length of the handle. A brass tack or screw can be inserted, after being soldered to wire leading from secondary in spark coil. The other wire leading from secondary should be grounded to gas stove to get a healthy spark, altho the handle wire should be sufficient. This device can be attached to the gas stove or any convenient place near the stove.

Contributed by ALVIN WALSTAD.

A Small Rectifier for Charging Storage Batteries

By ELLIOTT A. WHITE

A SMALL Tungar rectifier for charging storage batteries from 110-volt 60-cycle alternating current requires a General Electric Company's Tungar rectifier tube and standard Edison base porcelain socket, and a step-down transformer giving 2 volts for

dimensions. The sizes of wire are: No. 10 D.C.C. or enameled for the 2-volt filament winding to carry the current of around 10 amperes, 8 turns being needed,

detailed above, and the projecting paper cut in with shears as far as the coil at each corner, then folded up over the outside of the coil. The whole is then covered with friction tape, ordinary coil-winding tape,

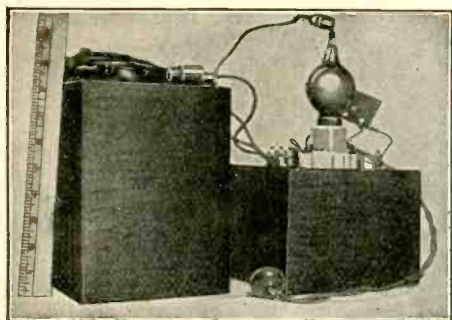

How the Author's Complete Vacuum Bulb Rectifier for Battery Charging Appears. The Size of the Apparatus Can be Judged by the Rule at the Left.

Cross-section of core in square inches.	Turns per volt.	Turns No. 20 DCC for 110-volt power winding.	Turns No. 18 DCC for 15-volt charging winding.	Turns No. 10 DCC for 2-volt filament winding.
1 " by 1 1/4 "	5.5	605	83	11
1 1/4 " by 1 1/4 "	5	550	75	10
1 1/4 " by 1 1/2 "	4.5	495	68	9
1 1/2 " by 1 1/2 "	4	440	60	8
1 1/2 " by 2 "	3.5	385	53	7
2 " by 2 "	3	330	45	6
2 1/2 " by 2 "	2.5	275	38	5

or 4 turns per volt; No. 18 D.C.C. or enameled for the 15-volt winding, to carry the 2-ampere charging current, 60 turns being required; and No. 20 D.C.C. or enameled to carry about 0.5 ampere for the 110-volt winding, 440 turns being required. The 110-volt winding is on one leg, and the other two windings together in one coil on the other leg.

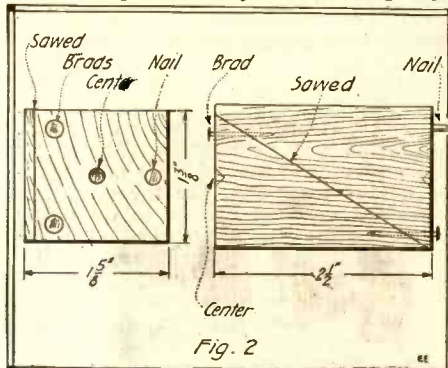

Detail View of Wooden Winding Form on Which Transformer Coils are Wound. The Diagonal Split Allows of Removing the Core From the Coil Easily.

the tube filament and 15 volts for charging. The small tubes are made in two sizes, of 2 and 5 amperes carrying capacity respectively. The outfit illustrated has a 2-ampere tube, costing a little over two dollars, and is suitable for charging storage batteries at a low rate.

The transformer, shown in Figure 1, has extreme dimensions of 5" by 5 7/8" by 2 3/4", and is of the closed core type. The core is 4" by 5" outside dimensions, with a 1 1/2" by 2 1/2" window and a cross-section of 1 1/4" by 1 1/2", built up of L-shaped stampings. For 60-cycle alternating current and a flux of 60,000 lines, the transformer equation $E = 4.44 \Phi f N \times 10^{-8}$

the winding formula $N = \frac{6.25 E}{A}$ where

N is the number of turns required for a given voltage E , and A is the area of cross-section of the core in square inches; that is, the number of turns required for any winding is equal to six and a quarter times the required voltage, divided by the cross sectional area of the core in square inches. Allowing for loss of area in stacking the core, the following table shows the number of turns required for the three windings for various sizes of core, so that material on hand may be used if desired.

The 1 1/4" by 1 1/2" core was the one used in the rectifier illustrated in the photograph, and its construction will be described. Other sizes of iron may be used equally well, with proper allowances in

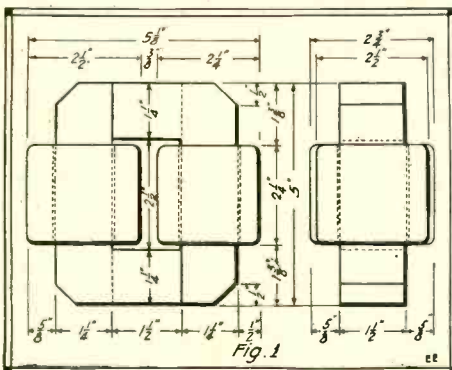

Side and Top Views of Rectifier Transformer.

It should be cut 1/16" larger than 1 5/8", that is, about 1 11/16" to allow for the width of the saw cut which, made diagonally, divides it into two lengthwise wedge-shaped pieces, held together by brads during the winding but easily removed from the finished coils by extracting the brads and pulling out one of the parts. The form may conveniently be placed between centers in a lathe, with a nail projecting from one end to catch in a dog so that it will turn with the chuck, which may be rotated by hand.

In making each of the two coils the form should first be wound with several layers of heavy paper, the ends of which are secured with shellac. This paper should be allowed to extend 1/2" or more beyond the ends of the block, to be used later. The wire is then wound on in even layers 2 1/4" long, to the required number of turns. At the end of each layer the turns may be held from slipping off by 4 short pieces of friction tape, folded once around the end turn (one piece on each side), the tape ends laid back on the surface of the coil, and succeeding turns wound over them to make them fast. When the coil is complete the form is removed from the center as

or cheap cotton tape 1/2" wide or more, threaded thru the coil and over the outside. This makes a neat and solid job. The tape may then be further secured with shellac. Sleeving should be slipped over the leads before putting on the tape. One coil consists of 440 turns, the 110-volt winding; the other coil of the 60-turn 15-volt winding inside, with the 8 turns of large wire for the 2-volt winding on the outside. The first coil will then have two leads, and the second coil four, two of which may be soldered together (the No. 10 wire being left for the lead), as the 2-volt and 15-volt windings have one terminal in common (see diagram in Fig. 3).

After the coils are finished they may be laid alongside of each other on a table, and the core built up inside of them. To make this easy, they should first be lined with heavy cardboard or fiber, projecting 1/8" beyond them at each end. The core is built up of ordinary transformer iron stampings 1 1/4" wide, cut in L-shaped pieces 5" by 2 3/4", the short side of the L being 1 1/2" in length (measuring from the inside edge of the long side of the L), to leave a window 1 1/2" wide by 2 1/2" long, as shown in Fig. 1. Two of the L-shaped pieces form one layer. They abut, and, in the same layer, do not overlap; therefore they should not be placed tightly against each other, but a space of 1/16" or more should be left between abutting edges. These gaps may be easily closed up afterwards with a hammer; but if they are put in tightly together

(Continued on page 958)

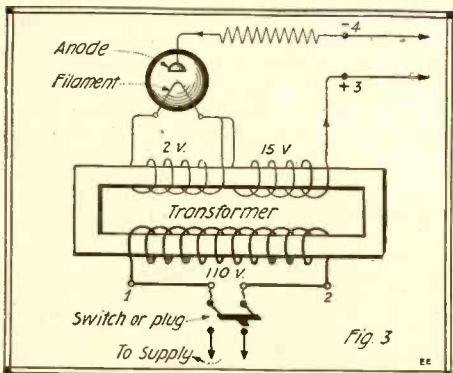

Hook-up of the Single Tube Rectifier for Half-Wave Rectifications of A-C into D-C for Battery Charging.

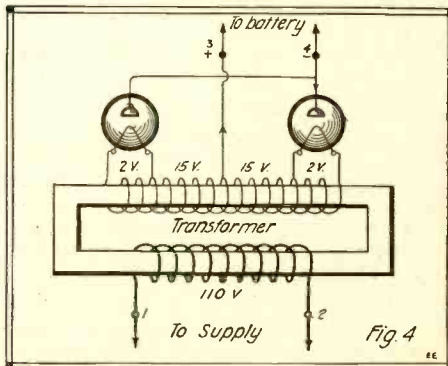

Connections of Two-Bulb Apparatus for Full Wave Rectification of A-C into D-C. This Type is the Most Satisfactory.

Calibrating Electrical Measuring Instruments

By THOMAS W. BENSON

THE experimenter usually has in his possession electrical measuring instruments of somewhat doubtful accuracy. The checking of these is quite a problem when standards are not available but by the method described here it becomes practical to check their readings with a high degree of accuracy.

By making use of a voltmeter we have certain standards that can easily be converted to our purposes, the more common forms of this instrument being the silver, copper and gas voltmeters. The silver voltmeter is unquestionably the most accurate of the three but, like the copper, it demands a sensitive balance to determine the amount of metal deposited. On the other hand the gas voltmeter requires but the measurement of the volume of gas liberated and since such measurement can be made with inexpensive pieces of apparatus this type was selected as the more suitable for general application.

A gas voltmeter can be constructed as shown in Fig. 1. A small glass bottle of wide mouth and two and a half inches high is arranged to be mounted on a base which supports an upright of wood one foot high and two inches wide. The cork for the bottle, which should be of rubber, has cut in it four holes. Two holes take carbon electrodes obtained from small flashlight batteries. These carbons are thoroughly cleaned by boiling in water for fifteen minutes to dissolve any soluble chemical that may be in the pores of the carbon. Flexible leads six inches long are soldered to the brass caps on the carbons before inserting

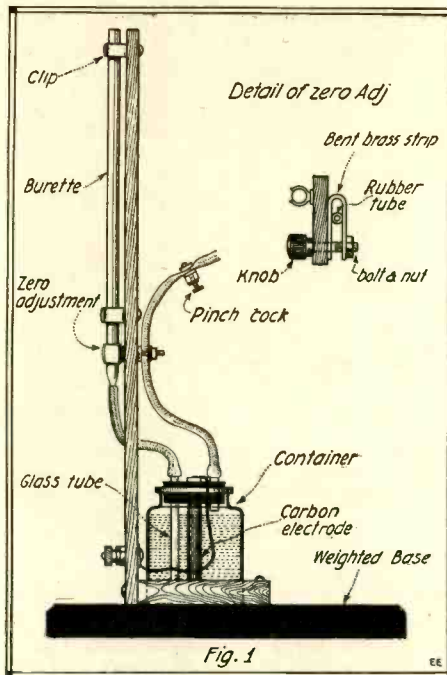

Homemade Calibrated Voltmeter. It Is of the Gas Type and Depends on the Measurement of Gas Liberated.

applying vaseline and binding with silk thread will assure this.

A second rubber tube is slipped over the other glass tube extending from the generator. This passes thru a clip operated by a knob on the front of the upright and is arranged to be closed at the top by a screw pinch-cock.

The adjusting clip is made from a strip of brass one-half inch wide and three inches long. Holes are drilled in the ends and the strip doubled in half. An 8/32 nut is soldered over one hole, a long 8/32 bolt fitted with a knob passes thru the upright and one end of brass strip and threads into the nut. Turning the knob one way or the other compresses or releases the tube.

To set the apparatus up. Assemble as shown in the illustration. From C. P. sulphuric acid and distilled water prepare sufficient 10 per cent electrolyte to slightly more than fill the bottle. Open the pinch-cock on the rubber tubing and pour the solution into the burette till the bottle is just full then close the pinch-cock. Pour in more electrolyte till it reaches the zero

mark on the burette or graduate tube.

The solution must first be saturated with oxyhydrogen gas. Connect the voltmeter to a source of current allowing one ampere to pass for a minute. The solution will rise in the burette in direct proportion to the gas generated, but take care that it does not flow over the top. Cut off the current and gently shake the apparatus for several minutes.

A wad of absorbent cotton can be put in the top of the burette or a short test tube inverted over it to keep out the dust. After each experiment the solution is returned to zero by opening the pinch-cock on the rubber tube, allowing the gas to escape. This should be done carefully so no electrolyte will be forced out of the tube. Fine adjustment of the column is obtained by the clip controlled by the knob on the front of the instrument. Careful workmanship and neat finish gives a very handsome instrument of value to every experimenter.

The instrument is now ready to be used as a standard for calibrating an ammeter. It has been determined by experiment that one ampere will liberate 0.1740 C. C. of oxyhydrogen gas in one second or 10.44 C. C. in one minute. The instrument described has a rating of nearly 60 coulombs, that is, it will measure current values to that amount. The maximum current, however, should not exceed five amperes; at this density the run should not exceed ten or eleven seconds.

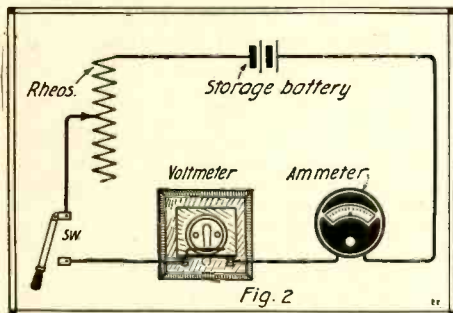

Hook-Up for Checking Ammeter With the Aid of the Voltmeter (at Left). Ammeter to Be Checked Is at Right of Circuit.

them in the rubber stopper. These leads to be connected to binding posts in the completed instrument.

Two glass tubes are put into the other holes, one reaching to within one-quarter inch of the bottom of the bottle, the other being flush with the bottom of the cork, both tubes extending one-half inch above the top of the cork.

The cork can then be fitted tightly into the bottle and sealed by painting the top of the bottle and cork with sealing wax dissolved in alcohol. The result is an air-tight seal, a necessity if the work is to be accurate.

This completes the apparatus for generating the gas, it remains to arrange some method for measuring it. The most suitable instrument is a Mohr burette of 10 C. C. capacity graduated to read .05 C. C. This can be purchased for 75 cents. Two clips are fastened to the upright to hold the burette. A hole is drilled in the upright four inches from the bottom to pass the rubber tube connecting the burette with the gas generator. The joints formed by the rubber and glass tubes must be perfectly tight,

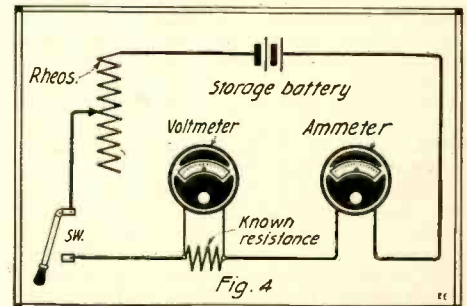

Circuit for Checking Voltmeter, Utilizing a Standard Resistance, and a Voltmeter as Well as Ammeter of Known Accuracy.

To check an ammeter connect as shown in Fig. 2. Two storage cells should be used to supply the current, a rheostat being inserted in the circuit to limit the current. Close the circuit and adjust the rheostat till the ammeter reads one ampere.

Open the circuit and bring the solution in the voltmeter to zero by opening the pinch-cock till it drops to zero. Final regulation is obtained by turning the knob on the adjusting clamp, thus compressing or releasing the tube, causing the column in the burette to rise or fall as necessary.

Now, with a watch in one hand, close the switch when the second hand reaches 60, note on a sheet the reading of the ammeter and open the circuit after 50 seconds. Read the C. C. of gas evolved directly from the level of the column in the burette, the actual amperes in the circuit being obtained by the formula:

$$I = \frac{G}{.174 \times S}$$

Where

G = C. C. of gas evolved as indicated by rise of solution in burette.

S = Seconds circuit is closed.

.174 = C. C. of gas evolved per second per ampere.

(Continued on page 958)

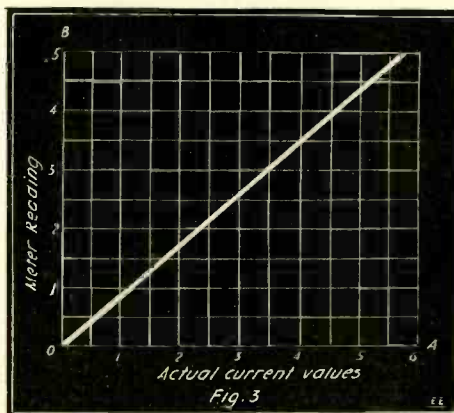

Correction Chart for Checking Up and Calibrating Ammeter. Chart Shows Meter Reading 10 Per Cent High.

Instrument for Measuring Radio-Activity

By IVAN CRAWFORD

THERE are many ways of measuring the Radio-activity of various substances, and perhaps the best is by means of the *gold-leaf electroscope*. The author has described this method of measurement in the January, 1919, issue of this journal. Do not think, however, that this is the only method which will give good results. The instrument which is described in this article is a combination of a torsion balance and an electroscope. With some care very accurate measurements can be made.

The torsion balance as devised by Coulomb consisted primarily of a non-conducting rod, having a small piece of metal on one end, suspended by means of a fine metal wire. A glass rod is arranged so as to have one end in the vicinity of the end of the non-conducting rod. When the glass rod is charged it attracts the metal on the end of the rod, and the force thus exerted is measured by the torsion exerted on the wire. Using this apparatus Coulomb, established the following laws of electrical action:

1. The repulsions or attractions between two electrified bodies are in inverse ratio to the squares of their distance.
2. The distance remaining the same, the force of attraction or repulsion between two electrified bodies is directly as the product of the quantities of electricity with which they are charged.

It will be found that these laws affect the working of the instrument which will now be discussed. For this attraction works also between two bodies, one charged and the other supposed to be uncharged. For a more detailed account of the action of the torsion balance, the reader is referred to any good physics text-book.

The construction of this instrument, which we shall call the "Torsion Electroscope," is illustrated in Fig. 1. The case is made of half inch oak, 12 inches in height, 5 inches broad, and 4 inches deep. The front of this case is a piece of ordinary window glass, which is held by means of spring clips. In the top of the case a small hole is cut, over which a brass strip is fastened. A spring clip or binding post is attached to this, thru which a round brass rod passes, having a hard rubber knob mounted on the upper end. The torsion portion is attached to the lower end of this rod by means of a drop of sealing wax. This permits easy adjustment of the torsion element of this instrument.

This torsion element is constructed as follows: A small lead weight is attached to one end of a silk fiber or hair, the other end of which is attached to the adjustable knob in the top. A small glass slip is at-

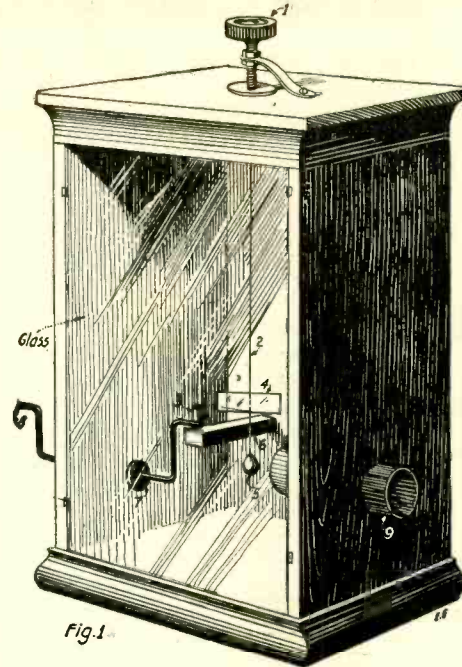

Fig. 1

- 1- Black composition knob. 2- Hair 3- Brass rod. 4- Thin glass slip. 5- Weight. 6- Sulphur insulation. 7- Sulphur insulation. 8- Charging rod. 9- Tube for introduction of active compounds.

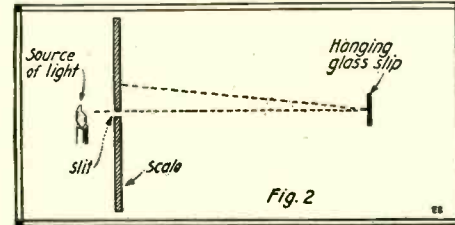

Fig. 2

The Reflected Light Ray System of the Radioscope.

tached to the hair about an inch above the weight. This slip is formed by cutting in two a thin square cover glass, such as is used in microscopical work. A small piece of gold leaf is now attached to one end of this glass slip, which in turn is attached to the hair by using a dab of sealing wax.

A wood support about three inches long is now fastened to the back of the case about three-quarters of an inch below the glass slip. The correct position for this support can only be found by direct experiment, as it varies on different instruments.

A round hole is bored in the end of this support. One end of a round brass rod about an inch and a half long, well smoothed and rounded, is inserted in this hole. The hole is now filled with melted sulfur, which when cold *insulates* this rod from the support. This is very important.

In order to *charge* this brass rod from the outside, a charger is arranged in the side of the case. A round hole about half an inch in diameter is cut in one side of the case, and a No. 14 copper wire past thru this. Melted sulfur is now poured into this hole. The wire is bent as indicated in the illustration, and in this manner the brass rod may be charged from the outside. In the other side of the case a round brass tube is placed in order to introduce *radio-active substances* into the case. This is accomplished by means of glass tubes and slides.

The movement of the glass slip is viewed by the use of apparatus illustrated in Fig. 2. A long cardboard scale is placed about a foot away from the case, having a slit cut in the center. A light placed behind this slit sends a beam of light to the glass slip, from which it is reflected back to the scale. The movement of the slip is thus greatly magnified on the scale.

The instrument is used as follows: The round brass rod is charged by turning the charging wire so that it makes contact with same, and then applying an electrified hard rubber rod to the outside end. The wire is then turned away by means of the charged rod so as not to discharge the rod. The hard rubber knob on the top is now adjusted so that the reflection from the glass slip is in the center of the scale. This means, then, that the *attraction* of the round brass rod for the gold leaf on the glass slip is exactly counterbalanced by the *torsion of the hair*. When a radio-active substance is now introduced into the case, the air is *ionized* by the rays, and the round brass rod slowly loses its charge. This allows the torsion of the hair to turn the slip, which movement is seen on the scale. The speed with which the reflection passes over a set number of divisions on the scale is a measure of the radio-activity of the substance. By this means, then, the radio-activity of substances can be accurately measured by watching the spot of light on the scale.

There are many other uses to which this instrument may be put, such as the measurement of the ionization caused by X-rays, ultra-violet rays, incandescent metals, et cetera, and it would be a useful acquisition for any Amateur Physicist's laboratory.

Wire Terminals from Rifle Shells

Good wire terminals can be made by securing copper rifle or revolver shells and placing them in a vise so as to flatten the cap ends. The holes can then be drilled easily. See illustration herewith.

Contributed by RAYMOND DUSSEL.



Good Wire Terminals or Lugs Can Be Fashioned from Copper Rifle Shells.

Bicycle-Lamp from Old Socket

Here is a drawing and description of a simple bicycle or trouble lamp.

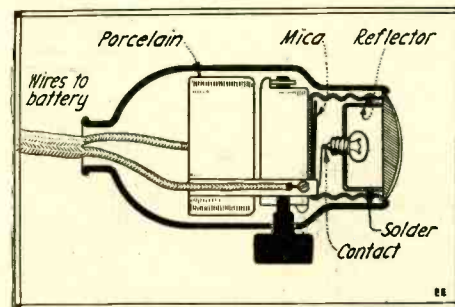

How to Construct a Bicycle-Lamp from a Discarded Socket.

This light can be made from an old electric light key socket and the reflector, together with the glass from a small two-cell tubular flashlight. The reflector is soldered inside of the socket in such a manner that it does not short-circuit it, but when a flashlight bulb is screwed in it, it will make a good connection with the center terminal. The glass is now filed around the edge until it is a tight fit for the small end of the socket case. But be sure it is in good and tight so that it will not be knocked out when the light is carried around. This makes a useful light for a bicycle or a trouble light for a car.

Contributed by CHAS. M. QUEEN.

Selective Switch for Three or More Interphones

Having occasion to use three of the ordinary Interphones, such as are used on lines up to 500 feet in length, I found they were

simply made up of parts obtainable at any electrical supply house. This switch is normally kept at the right, on dead contact point.

When the user wishes to call a station, he moves the switch blade to the point corresponding to the number of the station he

the 'phone to wire No. 5. Connect switch-blade to new wire and also connect new switch contacts to this wire. Other connections are made in duplicate of those in sketch.

Contributed by RAYMOND A. RANSOME.

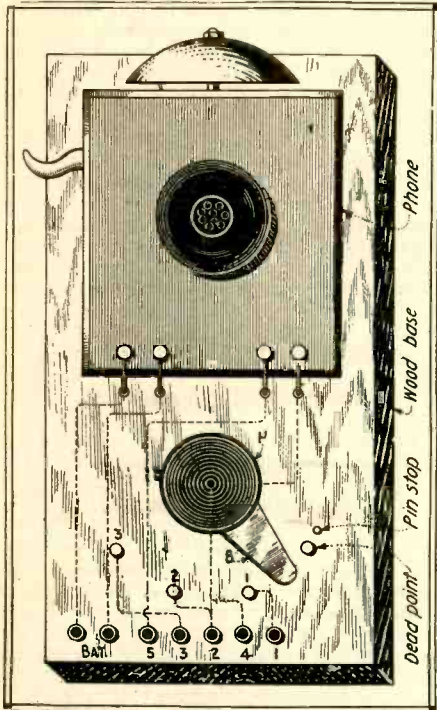

Making an Inter-Communicating Telephone From a Common Battery Type Instrument. A Switch and Base Board Are the Only Extra Parts.

only intended to be used between two stations.

The solution is in the selective switch and wiring diagram illustrated. The switch is

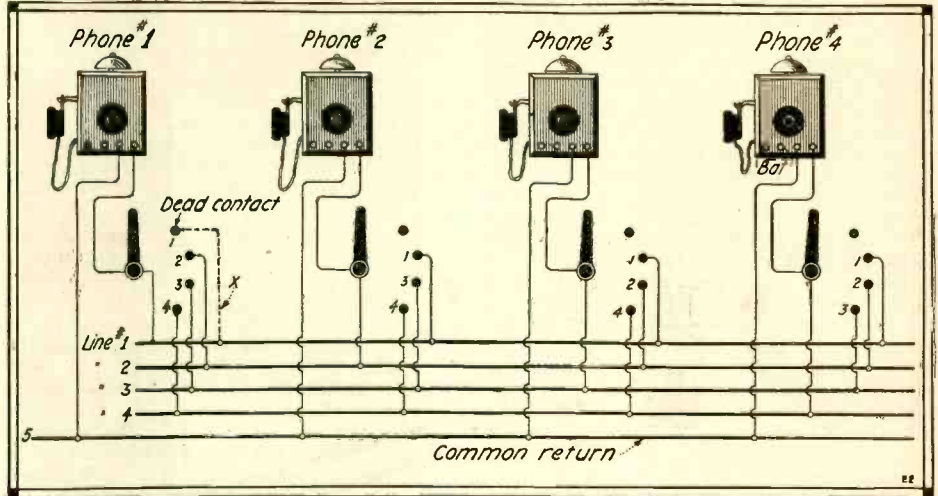

A 4-Station Inter-Communicating Telephone System Employing Simple Battery Instruments, Converted to Multiple Station Types as Shown in Drawing at Left. A Battery Is Used at Each Telephone, the Ringing Buttons Being on the Instruments Themselves.

is calling. The 'phone is then employed in the usual way. Upon finishing the message, the handle H must be turned so that switch-blade B is on dead contact, or as far to right as it will go.

This system takes care of as many 'phones as desired. If the user wishes to connect another 'phone, he needs only to run one additional wire and add one contact to each switch. Connect one side of

[Ed. Note: It is usually found in practice that more satisfactory results are obtained if the "home line" connection "X" is made to the "home point" on the switch instead of directly to the switch-blade as here shown by the full line. Otherwise, when two parties are talking, for instance Nos. 1 and 3, then party No. 2 or 4 can ring in your ear or cause interference.]

Home Made Electric Iron

Here's how to convert your sad iron into a glad iron. This is an electric iron that any amateur electrician can make. It is useful, cheap and can stand a great deal of use and abuse. Its construction is simple, and the parts easy to obtain. The drawing will explain the iron fully. The iron is an ordinary flat-iron fixt up as shown in the drawing.

The nichrome resistance wire for the element may be obtained from an electrical supply dealer by getting him to save the old elements he takes out of the standard electric irons for you. The nichrome wire referred to in the drawing was obtained from a Westinghouse heating element. The material was 1/16" ribbon nichrome. New elements for irons may be bought, but are somewhat expensive. The wire is unwound and flattened out. It is wound on 1/32" mica cut out as per drawing. In rewinding, care should be taken to follow the drawing closely as it is very puzzling at first to bring out

an end of the wire at each side. By carefully following the drawing there should be no trouble in constructing it. A layer of mica is put on both sides for insulation. The bottom plate is made of cold rolled steel and cut out the shape of the iron. To conserve the heat there should be a piece of thin asbestos of the proper thickness placed around the edge between the top and bottom of the iron, indicated at XX.

The connection block is made of transite or asbestos board. A connection plug may either be bought or made. If you have an electric appliance with a plug on it a very good idea is to use it for both, such as I have done. The distance, therefore, between the plugs on the connection block depends on the plug used.

The cap screw should be tightened up real snugly and the bottom filed flush. It should then be smoothed and polished. The iron is now ready for use.

Such an electric sad iron will prove a boon to mother and the girls and you will gain their everlasting gratitude by giving them such a convenience—indeed a necessity, today. The longer the ribbon, the higher its resistance and the lower the current as well as the heat produced.

Contributed by PAUL LIFSCHITZ.

[Editor's Note:—On receipt of stamped, address envelope, names of concerns supplying suitable resistance ribbons and wires will be furnished gratis.]

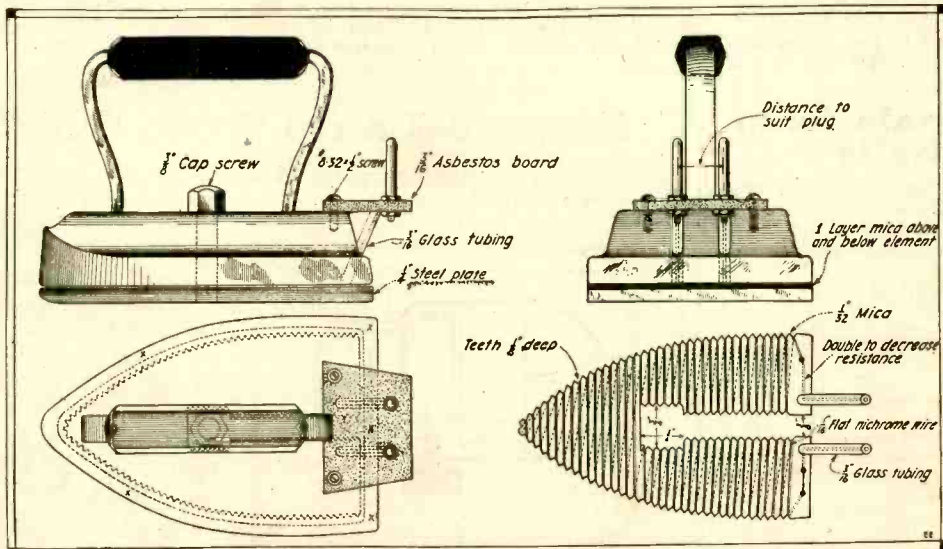

A Good Design of Home Built Electric Sad Iron. The Resistance Wire Is Wound on a Mica Sheet as Indicated.

The Electrical Machinist

By H. WINFIELD SECOR

No. 3—Motor Journals and Bearings.

IN the repairing of electric motors and dynamos, particularly in the smaller sizes, and a great deal of which is encountered in the electrical machine and repair shop, there are a number of interesting wrinkles which we will con-

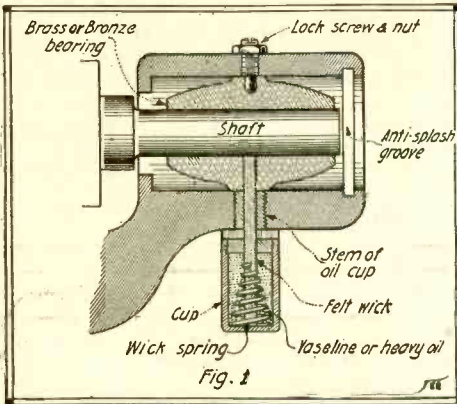

Typical Small Size Motor Bearing, Fitted With Wick Oiling System, Grease Cups, etc.

sider here. At figure 1, is shown a typical small size motor bearing with its oil feed cup of the wick type. This type of bearing is used on many different makes of electric motors of $\frac{1}{8}$ to $\frac{1}{4}$ H.P. It is also used on practically all electric fan motors. This oil cup and bearing design is simple and time has shown that it is thoroughly satisfactory for small and medium size bearings.

The brass cup is threaded to a shoulder provided with a threaded stem which fits up into the bearing in the manner shown. The cup is usually filled with a cheap grade of vaseline or else heavy machine oil. The lubricant is fed to the bearing by capillary attraction thru the wick, and the wick is prest against the journal of the shaft revolving in the bearing, by the wick spring,—this spring being clamped or riveted thru a hole, or otherwise, onto the wick, so as to maintain steady pressure upward on this member.

The bearing housing is, in the better class of motors, carefully designed with

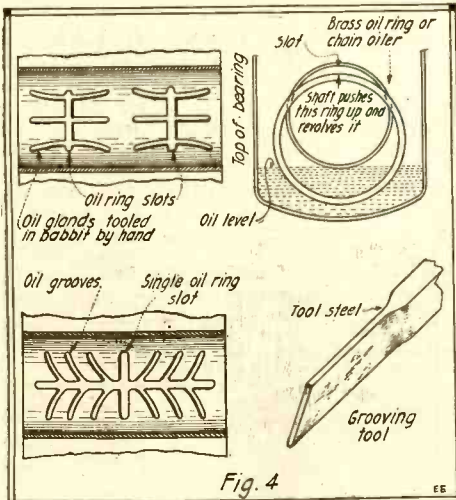

How Rebabbed Bearings are Grooved to Distribute Oil to Shaft Journal From Oil Rings.

oil retaining rings or anti-splash grooves on both front and back, so that in the event that too much oil is fed to the bearing, it will not be thrown out.

The bearing itself is usually of brass or phosphor bronze, preferably the latter, and phosphor bronze bearings are used in all size of motors and dynamos, and other machinery, it having proved one of the very best metals for this purpose.

Many motors and dynamos above $\frac{1}{4}$ to $\frac{1}{2}$ horsepower are provided with babbit metal bearings, and several makes of even the larger size machines are provided with steel and cast iron bearing sleeves, held in the bearing proper by babbit metal, as shown in Fig. 3.

In repairing machines in general, it is usual to try and purchase a new bearing from the manufacturer or from a supply house dealing in these parts, which often saves considerable time and makes a far better job all around. Fan bearings are usually procurable from any fan supply dealer or else from the manufacturer of the fan, whose name appears on the name plate thereon, invariably. The amount of play in the shaft can be easily judged at any time by taking hold of the commutator or the end of the shaft, by working it first sidewise and then up and down, and vertically. If this motion exceeds $\frac{1}{32}$ of an inch in the smaller machines it is not usually permissible to let this pass, and a new bearing should be substituted or else a relined one, more about which will be said anon.

REBUSING WORN SHAFTS.

It is not always the bearing that wears, however, as in some cases the shaft, particularly if it is a very mild or soft steel, will "cut" until it is filled with grooves, even to the point where it resembles a machine screw. Of course it is foolish to place a new bearing or bearings in a machine in which the shaft is worn to such an extent.

Some electrical machinists follow the easiest road in such a case and simply take a pair of somewhat smaller bearings and turn down the shaft to fit it, thus obtaining a new and smooth cylindrical surface on the shaft. This is sometimes permissible, but usually it is unsatisfactory for the reason that the designer of the machine made the shaft of its original diameter so that it would not heat up on long runs, etc. Therefore the original size of the shaft should be retained whenever possible, and it is the standard rule in all first class electrical repair shops, to maintain this practise.

Figure 2 shows how such a worn shaft is "rebused," in this case, with a steel sleeve shrunk onto a turned down journal. At figure A, the worn journal is shown clearly and also the part which is to be cut away in the lathe.

By means of inside and outside calipers, the reduced portion of the journal is machined with a diamond-point shaped tool, until it is of the same diameter as the inside bore of the bushing, finishing the turned down shoulder as smooth as possible and touching it up a bit with a fine-cut file. The steel bushing is then expanded so as to be driven onto the stem without too much pressure, by heating it cherry red in a gas or other flame.

Fig. 2-B shows the steel bushing driven into place on the journal, and it is then allowed to cool. Provided the fit has been properly made, it will be held very firmly on the shaft. The new journal is then turned down to the proper size to fit in the original bearing as shown in Fig. C. Hun-

dreds of armatures have been saved in this way from the scrap pile in several large repair shops with which the writer has been connected, and a first class job is invariably the result. At this point it should be mentioned that the armature must be watched very carefully while machining the

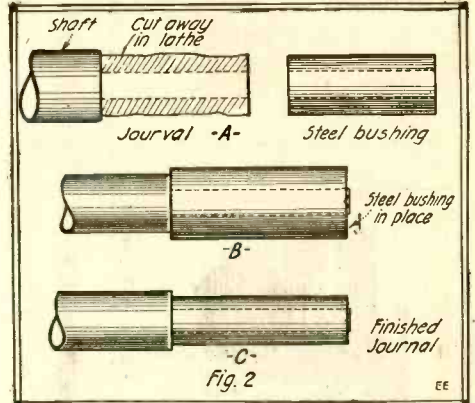

Showing How a Badly Cut Shaft Was Rebused so as to Fit Standard Size Bearing.

shaft in this manner, so that the tool carriage, etc., should not touch the armature and damage the winding. A trick of the electrical machinist in connection with this work is one which, while fraught with the danger of short-circuiting the winding and necessitating the entire rewinding of the armature, is to turn down or file very carefully, the surface of the armature drum. This is sometimes done when after a repair job of this or similar character, the armature is slightly out of center, and comes too close to the pole-pieces of the machine. As before mentioned, it is hardly to be recommended, but as this has been done many times in electrical repair shops, it is mentioned here for what it is worth, and providing the laminations of the arma-

(Continued on page 952)

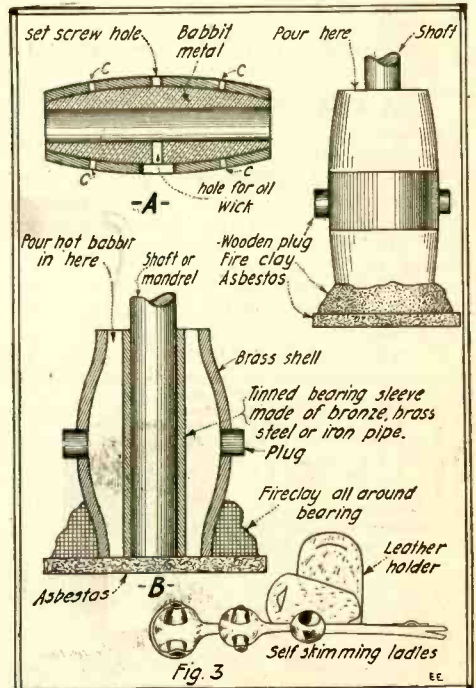

Various Steps Followed In Rebabbing Bearings. At Bottom—New Self-Skimming Ladles and Leather Holders for Ladles.

HOW-TO-MAKE-IT

This department will award the following monthly prizes: First Prize, \$3.00; Second Prize, \$2.00; Third Prize, \$1.00. The purpose of this department is to stimulate experimenters towards accomplishing new things with old apparatus or old material, and for the most useful, practical and original idea submitted to the Editors of this department, a monthly series of prizes will be awarded. For the best idea submitted a prize of \$3.00 is awarded; for the second best idea a \$2.00 prize, and for the third best prize of \$1.00. The article need not be very elaborate, and rough sketches are sufficient. We will make the mechanical drawings. Use only one side of sheet. Make sketches on separate sheets.

FIRST PRIZE, \$3.00

USING MAGNETO ON TOY TRANSFORMER.

An inexpensive source of current for our young Experimenters can easily be ob-

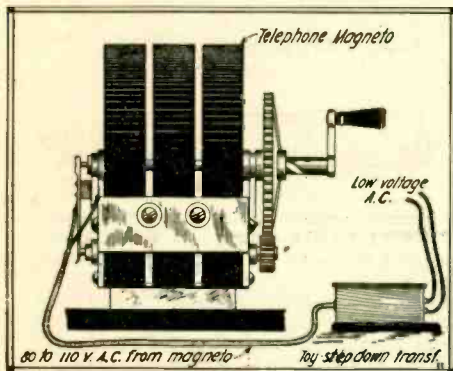

A Clever Stunt—Using the Magneto on a Step-Down Transformer for Ringing Bells, Operating Small Motors, Etc.

tained with the following apparatus: A 110-volt telephone magneto generator, and a toy step-down transformer are all that is necessary. The plug should be removed from the transformer and the wires connected to the magneto as shown in diagram. The magneto may be operated by crank handle or attached to sewing machine, water motor, or other surplus power. The current obtained from the terminals when the magneto is run at a moderate rate of speed, is strong enough to ring bells, operate buzzers, etc., and should prove very useful when a small amount of current is required.

Contributed by JOHN P. SORENSEN.

A TEA-KETTLE ALARM.

Now that the winter days are here, the housewife will be anxious to have a kettle alarm undoubtedly, one that will tell her when the water is boiling, instead of having to wait in the kitchen to ascertain this fact. This electric alarm device should be of convenience to her. The aluminum which is heated by the hot steam expands, thereby making a circuit which rings the bell.

Contributed by GARRETT WOLPERT.

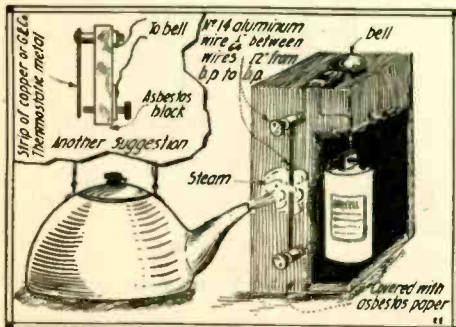

When the Steam From the Tea Kettle Expands the Metal Strips, They Touch and Close the Alarm Bell Circuit.

SECOND PRIZE, \$2.00

A HIGH-POWER PHOTO PRINTER OF TRIED DESIGN

Having been a reader of ELECTRICAL EXPERIMENTER for some time, being an engineer by profession, also a hobby rider, the writer is taking the liberty of submitting to this Department a device which it is thought many people inclined to do photographic printing will appreciate.

The accompanying sketch explains the device in detail. It is designed from one which was constructed from shop odds-and-ends, and has for some time been doing continuous daily service in one of the Government photographic laboratories at Washington, D. C.

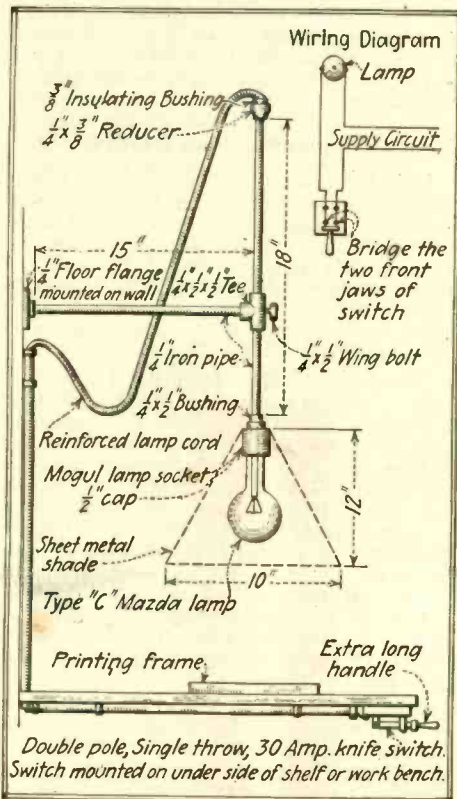

A Rapid Photo-Printer Which Has Been Tried by the Author.

Printing machines, boxes and other devices have their advantages, but this device is possesst of a number of valuable features.

Some features: Inexpensive to make; readily adjustable; very little maintenance required; simple to operate; has maximum factor of safety; all forms of "dodging" and "shading" printing readily performed; if desired medium lamp socket may be used in place of Mogul socket and intensity of printing light easily varied by changing various sizes of light bulbs or an adapter may be used in the Mogul socket to accommodate bulbs with medium-sized bases.

Contributed by

C. A. PURDY.

THIRD PRIZE, \$1.00

THE SIMPLEST BELL—WORKS BY GRAVITY.

Herewith is a sketch of a gravity-operated bell which I have made.

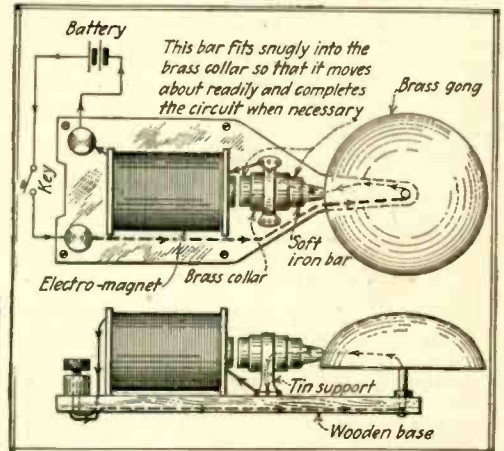

Very Simple Form of Electric Bell—the Circuit Is Made and Broken by the Rise and Fall of the Hammer by Gravity.

The simplicity of this bell enables anybody to make one for his own use. It consists of an electro-magnet, an iron bolt-head or bar (which is able to slide readily thru a brass collar) and a brass bell or gong.

When the circuit is closed the magnet is energized and attracts the iron core. This opens the circuit as the core is pulled away from the gong; and the weight of the hammer forces it down upon the bell, thus completing the circuit once more. This action is continuous. This type of bell does not necessitate a spring.

Contributed by MANUEL E. SPRING.

LAMP RECEPTACLE A HANDY MATCH HOLDER.

A match holder may easily be made from the porcelain portion of a discarded electric light receptacle. A piece of cigar box or other wood may be fastened to the bottom by means of screws. A piece of sandpaper may be glued to the side if desired.

Contributed by ALTON D. SPENCER.

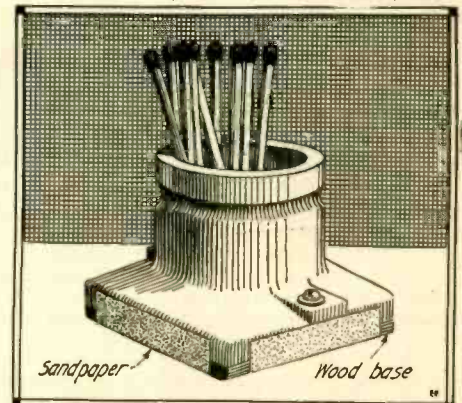

Porcelain Lamp Receptacle Serves as an Effective Match Holder.



EDITED BY S. GERNSBACK

SILVER PLATING SCIENTIFICALLY DONE.

Silver plating by electrolysis, the amateur usually finds a difficult operation. But this is because he does not know and observe the necessary precautions. In electroplating of all kinds the prime consideration is absolute cleanliness.

Set up your plating bath as shown in the diagram, using about 8 gravity cells or 4 storage cells. An ammeter connected as shown is highly desirable. A solid silver anode about the size of a quarter must be suspended at the positive pole and the object to be plated at the cathode or negative pole.

First polish the object to be plated after

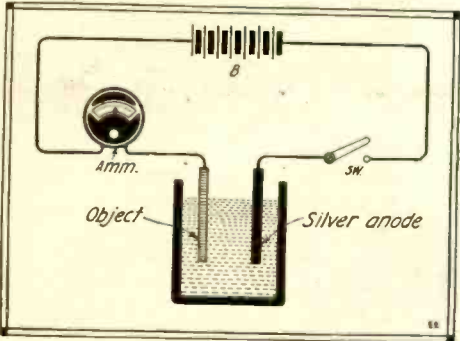

Diagram Showing How to Set Up the Silver-plating Outfit.

which remove the grease that will surely adhere to it by dipping in water and then for a half minute in a cleaning solution made as follows:

Caustic soda.....100 grams
Water (preferably distilled).....1000 c.c.
The temperature of this solution should be about 40 degrees Centigrade, or 104 degrees Fahrenheit. Remove the object, rinse in clear water and then to remove certain oxides that still remain on the surface dip for a half minute in the following solution:

Potassium cyanide (very poisonous) 25 grams
Water (preferably distilled).....1000 c.c.
After removing from this solution rinse as before in clear water and avoid throat handling with the fingers, which will again leave grease upon the surface.

Now to roughen the surface so the silver will get a firm grasp place the object for a few seconds in the following solution:

Mercury (dissolved in dilute nitric acid) 1 gram
Water2000 c.c.
Then quickly rinse in about 2 quarts of clean water.

The plating bath itself is made as follows: Dissolve 56 grams of silver nitrate in a small volume of water and likewise 50 grams of common table salt in another equal volume of water. Mix the two solutions and white silver chloride will precipitate. Filter this precipitate in the ordinary way with funnel and filter paper, or better still thru clean unbleached muslin. Wash the residue left on the filter by pouring water thru it.

Then make another solution of 225 grams of potassium cyanide in 1600 c.c. of water and in this solution dissolve the residue of silver chloride from the previous operation.

Heat the plating solution to about 45 degrees Centigrade or 113 degrees Fahrenheit and place in the plating jar. Having placed

the object to be plated at the cathode, close the switch and allow a current of 2 amperes to flow for 30 seconds.

Then remove the work and rub with very fine sand to determine whether the silver is depositing evenly. If it is not, repeat the whole process, starting with the first cleaning solution and ending with the electrolytic deposition of silver having as before a current of 2 amperes.

Now cut out all but one cell and with a current of about 3/10 of an ampere continue the process until the requisite thickness of silver has been deposited.

Remove the object, rinse in water, burnish and buff it. Rubbing with rouge—red oxide of iron—is the best method of buffing.

In using cyanides exercise the utmost care. Do not inhale cyanide fumes, for they are poisonous.

Contributed by FLOYD L. DARROW.

THE CRITICAL STATE OF MATTER.

When a gas is at the critical temperature and at the critical pressure also, the increase of pressure or decrease of temperature will convert it into a liquid. When in this condition a gas is said to be in its critical state.

The phenomena of the critical state can be beautifully shown as follows:—Select a test tube at least 8 in. in length and 1 in. in diameter. This should be filled with paraffine. Also procure a glass tube about

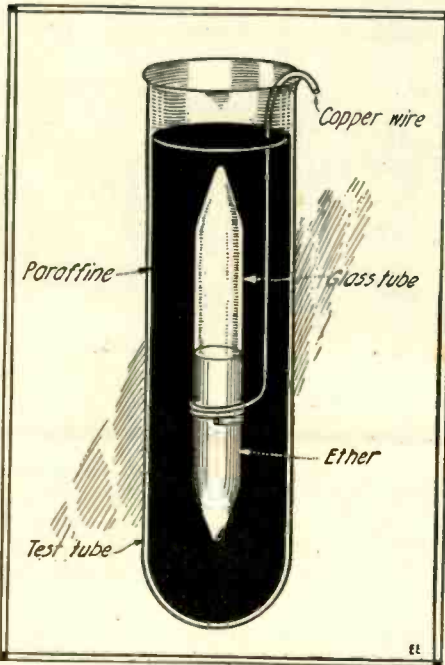

A Fine Experiment to Demonstrate the Critical State of Matter. Caution! Use Wire Netting Over Your Gas Flame When Sealing Ether Tube. Very Inflammable.

4 in. long and 5 mm. outside diameter. Seal one end by holding in a flame. Fill one-half full with ether, and seal other end with blowpipe. The paraffine is now melted by holding test tube in flame, and the small tube suspended in it by means of a wire, as shown in illustration. On continuing to heat the wax the ether will go thru the critical state.

The first indication of a change of state is the disappearance of the meniscus (the upper curved surface of a liquid), immediately following this flickering striae appear, unrest pervades the tube, and then the liquid has become a gas.

Contributed by ERNEST LINDER.

NOVEL DRYING TUBE FOR GAS GENERATOR.

Large or medium size test tubes break quite frequently, and these tubes may be put to good use by making drying tubes

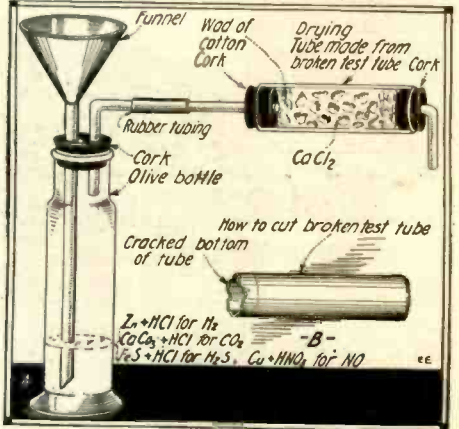

Gas Should Be as Dry as Possible. This Inexpensive Gas Dryer Should Be Welcome in Every Laboratory.

from them. This is done by cutting off the cracked part (B). Procure two corks to fit the ends, each having a hole thru which a small straight or curved piece of tubing passes. (A). Insert one of the corks, and on top of this a small wad of cotton. Then fill the tube with calcium chloride, leaving enough room for another wad of cotton and the other cork. This dries the gases very well.

The generator can be made from a small olive bottle. (A). Bore two holes in its cork, and in one insert a funnel tube, thru the other a delivery tube. This apparatus when made costs practically nothing. Even the funnel can be made from glass tubing, with a little care.

If it is charged with hydrochloric acid (or sulfuric) and zinc; hydrogen is generated, and is freed from moisture on passing thru the drying tube. It is then good for the marsh gas test, it being necessary to have the gas dried for this test. If charged with calcium carbonate or marble, and hydrochloric acid, carbon dioxide is generated. If iron sulfid and hydrochloric acid are placed in it, hydrogen sulfid is produced, and this apparatus can be utilized for making nitrous oxide by charging it with scrap copper and dilute nitric acid. Of course, separate ones can be made for each gas, which would be better, as the material is not very expensive.

Contributed by EDWARD MARENZANA.

CEMENT TO MEND LEAKY BOILERS.

Powdered litharge, 2 parts, very fine sand, 2 parts, slaked quick lime, 1 part. Mix all together. To use, mix the proper quantity with boiled linseed oil and apply quick. It gets hard very soon.

possible to revolve the loop 300 degrees with ease. Contrary to popular belief the loop is not exposed outside of the compass house. Instead, and as will be noted from the accompanying figure, the loop is inclosed within the house and thus protected from the elements. The house or cabin is built entirely of wood and other non-mag-

netic materials. The receiving apparatus which accom-

panies the loop is situated in the lower part of the room and consists of a specially

shacks along the coast are even remotely associated with radio work.

The receiving apparatus which accom-

panies the loop is situated in the lower part of the room and consists of a specially

shacks along the coast are even remotely associated with radio work.

The receiving apparatus which accom-

panies the loop is situated in the lower part of the room and consists of a specially

shacks along the coast are even remotely associated with radio work.

The receiving apparatus which accom-

panies the loop is situated in the lower part of the room and consists of a specially

shacks along the coast are even remotely associated with radio work.

The receiving apparatus which accom-

panies the loop is situated in the lower part of the room and consists of a specially

say, it is surrounded from all sides by a grounded copper netting. This precaution is necessary in order that possible stray external oscillations be warded off from the receiver, otherwise these undesirable currents would influence the receiving apparatus and render loop bearings inaccurate.

Fig. 6 is a schematic circuit diagram of the radio compass. It will be noted that no ground circuit is employed and that the loop leads are connected directly to the loading coil of the secondary inductance, instead of the primary, as is customary in other receiving circuits. No use is made of the primary; the loop circuit being a direct-coupled one.

THEORY OF OPERATION.

In order to properly understand how the radio compass functions, it is perhaps not untimely to explain a few fundamental facts concerning its theory.

To begin with, one may as well be reminded that present day investigators have decided that the radiated oscillations from any radio transmitter travel over the earth's surface in undulating waves having a broad flat front; in other words sine waves, similar to alternating currents, shown in Fig. 2. The distance from A to B is equal to the actual wavelength of that particular transmitter, which in this case we assume to be 600 meters.

Now if the plane of the loop windings is set at right angles to the advancing wave (Continued on page 949)

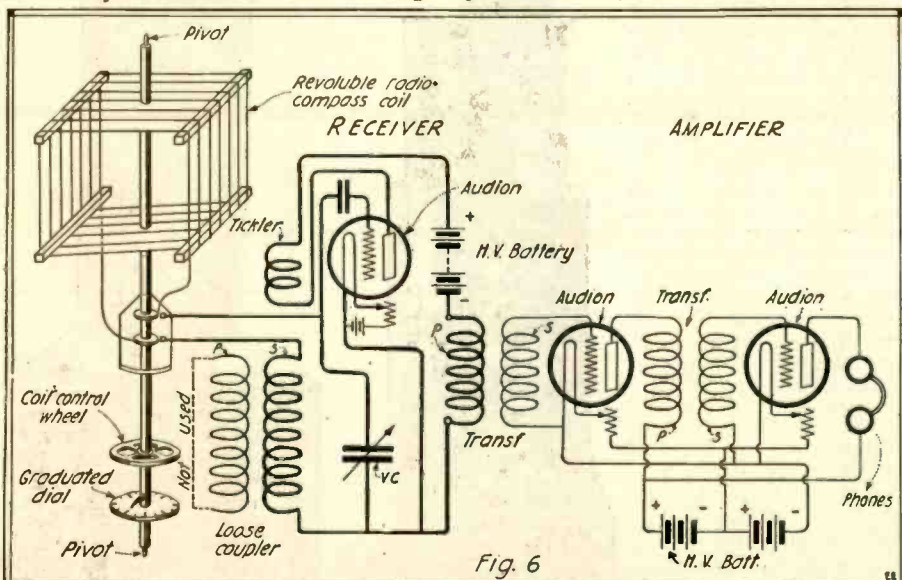
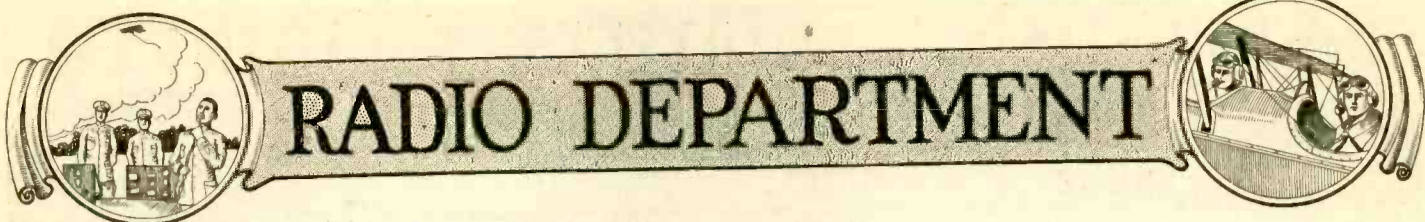

Fig. 6

The Connections Used in U. S. Naval "Radio Compass" Stations. The Details of the Loop Antenna Are Given in the Text.

RADIO DEPARTMENT

The Radio Compass

By **PIERRE H. BOUCHERON**, Ensign U. S. N. R. F.

IN the bewildering maze of inventions and discoveries which have been developed during the very short years following the entry of the United States into the World War, there stands out an instrument which has the

What It Is—What It Does—How It Does It—Who Makes Use of It
the navigation of ships almost fool-proof.

and receiving "radio-goniometers." The receiving goniometer was later modified and adopted by the Marconi Co., and at the beginning of the war was considered the most developed and accurate radio compass of the day. It took a war to bring the de-



An Oscillion Radio Telephone and Telegraph

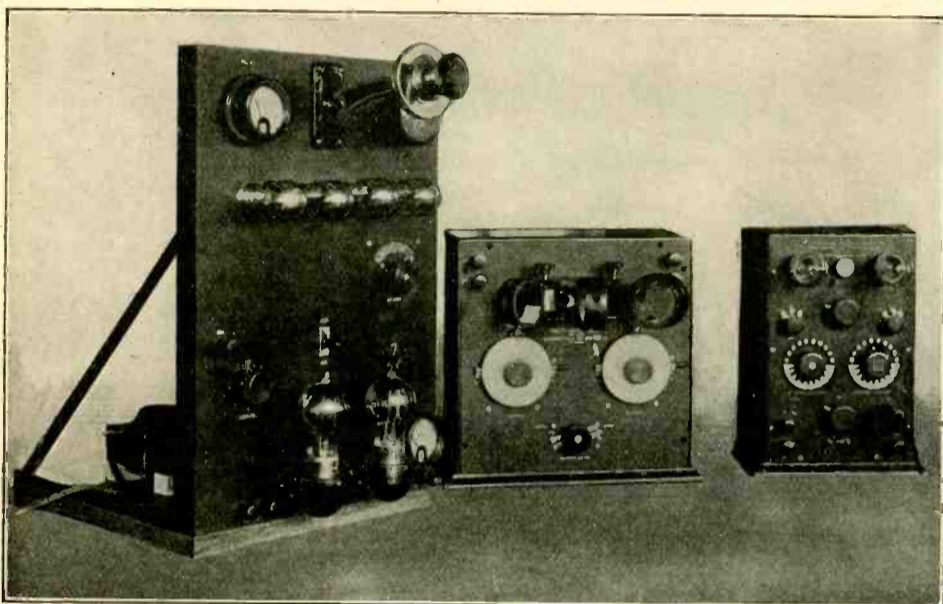

The New De Forest Radio Phone, So Simple That a Child Can Operate It. It Works on A. C., Thanks to the Two Rectifier Tubes Seen at the Bottom of the Apparatus at the Left. Just Press a Button and Talk—More Simple Than the Regular Telephone, Eh?

ALTHO the A. C. Oscillion Radiophone Transmitter is something entirely new on the radio market, it has been so carefully designed and constructed that it is claimed to be a practical instrument which may be relied upon to give excellent service over short ranges. The operation

of the instrument is quite simple. All that is necessary is to connect the power leads of the set to the ordinary house lighting circuit, connect *antenna* and *ground* to the terminals of the set, push a button and *talk*.

The set needs to be adjusted but once.

This may be done when it is installed and once these adjustments have been made it will need no further attention. Absolutely no knowledge of radio telephony is necessary to successfully operate the set, and the non-technical man can run it just as well as the most up to date radio engineer. It is as simple in operation as the ordinary house telephone.

One of the advantages of this radio telephone which will be duly appreciated by those who have had experience with the older types is the remote control system, by which the antenna is automatically connected to either the transmitter or receiver, by merely pushing a button.

The telephone is designed primarily for 200 meter transmission, but sets can be made to operate on other wavelengths when desired. One 6-volt storage battery is needed in connection with the telephone to operate the microphone and the remote control relay. Any standard storage battery will be satisfactory for this work. Using this radio telephone in conjunction with standard receiving equipment ranges of ten miles and over may be reliably covered with a moderate sized antenna.

The panel on which the apparatus is mounted is of Bakelite 14x20 inches. It sets on an oak base 14x15 inches so that the complete set occupies a minimum of space. At the top of the panel is mounted a microphone transmitter of the usual type on an arm, to the right and left of which is located the plate circuit milliammeter and the filament ammeters respectively.

(Continued on page 954)

New Undamped Radio Receiver

Have you enjoyed the thrill of listening to the piercing whistle of the numerous undamped wave stations now operating here and abroad? Well, the pleasure is all yours, especially so as the number of stations using this method of transmission is increasing yearly, already all the Government land stations of importance are equipped for sending and receiving, while all the battleships are equipped for receiving, their transmitters being installed as quickly as time will allow.

The tone of the undamped signals can be varied from the lowest known to inaudibility; it is therefore possible to select any pitch best suited for receiving. This phenomenon is indeed interesting and in strong contrast to the spark method whose tone is fixt.

A glance at the illustration will disclose the advantages of the vertical mounting over the cumbersome horizontal method which occupies unnecessary space on the operating table, besides being harder to operate.

The principle is regenerative in action, resulting in amplification. In its construction a high grade of insulating material is used upon which are mounted all the metal parts carrying the oscillating currents. The windings are machine wound with enameled wire on substantial tubes. The compound switch permits fine adjustment on the primary inductance. The counter-balanced secondary is a unique feature which eliminates all difficulty in tuning, instantly responding to the slightest touch and remaining in any position. The balancing weight is contained in the long brass tube which permits the secondary to be loose-coupled six inches, resulting in highly selective tuning.

The set has a wave length range up to 18,000 meters on a moderate size antenna.

The detector is of the panel type, using the tubular bulb producing a pure electron

discharge. The telephone battery is enclosed in the cabinet and has a pressure of 40 volts, which can be finely adjusted by the 19-point high voltage switch.

To renew the batteries it is only necessary to remove several screws on the panel and base, thereby displacing the cabinet and making renewal easily accomplished. All connecting posts are clearly marked in white letters, these being engraved in the panel. The oscillating inductance is machine wound with enameled wire on a substantial tube fitted with a positive contact switch, which allows of sufficiently fine variation. The entire set is furnished in a mahogany-finished cabinet, all metal parts being nickelled. The height of the apparatus is 32 inches.

Loose couplers have from time to time demonstrated their efficiency in being able to tune out all those stations not desired and allowing those which the operator intends to receive from to come in with marked clarity and intensity. Many have raised objections to their use, however, stating that they were inefficient because of their coupling, but very few have been able to produce other apparatus to replace them, and which would be so universally accepted "the best ever." So it stands to reason that they are to remain.

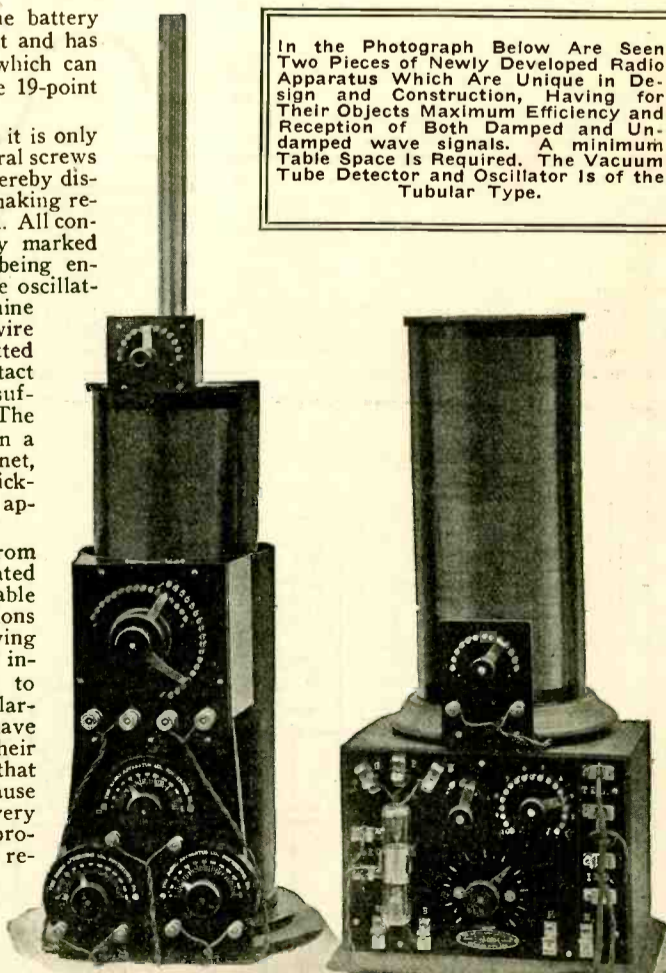

In the Photograph Below Are Seen Two Pieces of Newly Developed Radio Apparatus Which Are Unique in Design and Construction, Having for Their Objects Maximum Efficiency and Reception of Both Damped and Undamped wave signals. A minimum Table Space Is Required. The Vacuum Tube Detector and Oscillator Is of the Tubular Type.



EDITED BY S. GERNSBACK

SILVER PLATING SCIENTIFICALLY DONE.

Silver plating by electrolysis, the amateur usually finds a difficult operation. But this is because he does not know and observe the necessary precautions. In electroplating of all kinds the prime consideration is absolute cleanliness.

Set up your plating bath as shown in the diagram, using about 8 gravity cells or 4 storage cells. An ammeter connected as shown is highly desirable. A solid silver anode about the size of a quarter must be suspended at the positive pole and the object to be plated at the cathode or negative pole.

First polish the object to be plated after

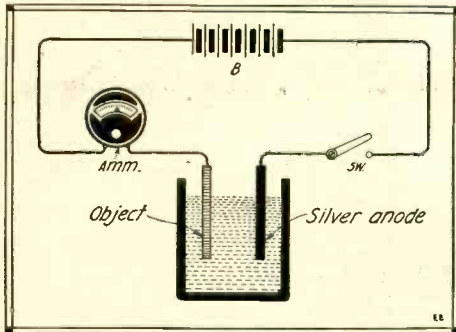

Diagram Showing How to Set Up the Silver-plating Outfit.

which remove the grease that will surely adhere to it by dipping in water and then for a half minute in a cleaning solution made as follows:

Caustic soda100 grams
Water (preferably distilled).....1000 c.c.
The temperature of this solution should be about 40 degrees Centigrade, or 104 degrees Fahrenheit. Remove the object, rinse in clear water and then to remove certain oxides that still remain on the surface dip for a half minute in the following solution: Potassium cyanide (very poisonous)

25 grams
Water (preferably distilled).....1000 c.c.
After removing from this solution rinse as before in clear water and avoid thruout handling with the fingers, which will again leave grease upon the surface.

Now to roughen the surface so the silver will get a firm grasp place the object for a few seconds in the following solution: Mercury (dissolved in dilute nitric acid)

1 gram
Water2000 c.c.
Then quickly rinse in about 2 quarts of clean water.

The plating bath itself is made as follows: Dissolve 56 grams of silver nitrate in a small volume of water and likewise 50 grams of common table salt in another equal volume of water. Mix the two solutions and white silver chloride will precipitate. Filter this precipitate in the ordinary way with funnel and filter paper, or better still thru clean unbleached muslin. Wash the residue left on the filter by pouring water thru it.

Then make another solution of 225 grams of potassium cyanide in 1600 c.c. of water and in this solution dissolve the residue of silver chloride from the previous operation.

Heat the plating solution to about 45 degrees Centigrade or 113 degrees Fahrenheit and place in the plating jar. Having placed

the object to be plated at the cathode, close the switch and allow a current of 2 amperes to flow for 30 seconds.

Then remove the work and rub with very fine sand to determine whether the silver is depositing evenly. If it is not, repeat the whole process, starting with the first cleaning solution and ending with the electrolytic deposition of silver having as before a current of 2 amperes.

Now cut out all but one cell and with a current of about 3/10 of an ampere continue the process until the requisite thickness of silver has been deposited.

Remove the object, rinse in water, burnish and buff it. Rubbing with rouge—red oxide of iron—is the best method of buffing.

In using cyanides exercise the utmost care. Do not inhale cyanide fumes, for they are poisonous.

Contributed by FLOYD L. DARROW.

THE CRITICAL STATE OF MATTER.

When a gas is at the critical temperature and at the critical pressure also, the increase of pressure or decrease of temperature will convert it into a liquid. When in this condition a gas is said to be in its critical state.

The phenomena of the critical state can be beautifully shown as follows:—Select a test tube at least 8 in. in length and 1 in. in diameter. This should be filled with paraffine. Also procure a glass tube about

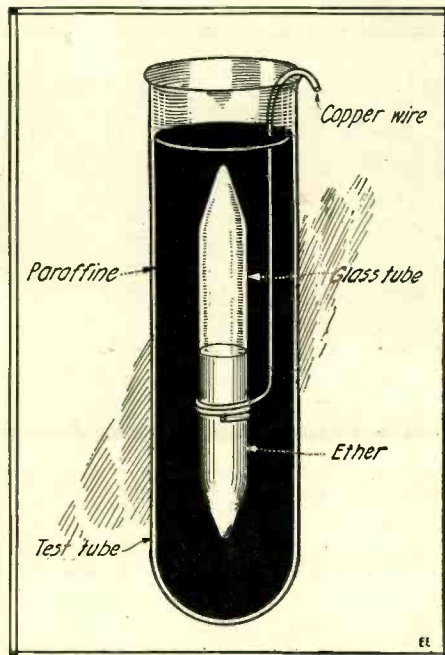

A Fine Experiment to Demonstrate the Critical State of Matter. Caution! Use Wire Netting Over Your Gas Flame When Sealing Ether Tube. Very Inflammable.

4 in. long and 5 mm. outside diameter. Seal one end by holding in a flame. Fill one-half full with ether, and seal other end with blowpipe. The paraffine is now melted by holding test tube in flame, and the small tube suspended in it by means of a wire, as shown in illustration. On continuing to heat the wax the ether will go thru the critical state.

The first indication of a change of state is the disappearance of the meniscus (the upper curved surface of a liquid), immediately following this flickering striae appear, unrest pervades the tube, and then the liquid has become a gas.

Contributed by ERNEST LINDER.

NOVEL DRYING TUBE FOR GAS GENERATOR.

Large or medium size test tubes break quite frequently, and these tubes may be put to good use by making drying tubes

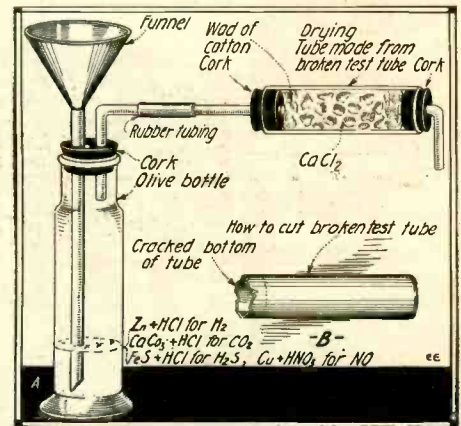

Gas Should Be as Dry as Possible. This Inexpensive Gas Dryer Should Be Welcome in Every Laboratory.

from them. This is done by cutting off the cracked part (B). Procure two corks to fit the ends, each having a hole thru which a small straight or curved piece of tubing passes. (A). Insert one of the corks, and on top of this a small wad of cotton. Then fill the tube with calcium chloride, leaving enough room for another wad of cotton and the other cork. This dries the gases very well.

The generator can be made from a small olive bottle. (A). Bore two holes in its cork, and in one insert a funnel tube, thru the other a delivery tube. This apparatus when made costs practically nothing. Even the funnel can be made from glass tubing, with a little care.

If it is charged with hydrochloric acid (or sulfuric) and zinc; hydrogen is generated, and is freed from moisture on passing thru the drying tube. It is then good for the marsh gas test, it being necessary to have the gas dried for this test. If charged with calcium carbonate or marble, and hydrochloric acid, carbon dioxide is generated. If iron sulfid and hydrochloric acid are placed in it, hydrogen sulfid is produced, and this apparatus can be utilized for making nitrous oxid by charging it with scrap copper and dilute nitric acid. Of course, separate ones can be made for each gas, which would be better, as the material is not very expensive.

Contributed by EDWARD MARENZANA.

CEMENT TO MEND LEAKY BOILERS.

Powdered litharge, 2 parts, very fine sand, 2 parts, slaked quick lime, 1 part. Mix all together. To use, mix the proper quantity with boiled linseed oil and apply quick. It gets hard very soon.



RADIO DEPARTMENT

The Radio Compass

By PIERRE H. BOUCHERON, Ensign U. S. N. R. F.

IN the bewildering maze of inventions and discoveries which have been developed during the very short years following the entry of the United States into the World War, there stands out an instrument which has the

What It Is—What It Does—How It Does It—Who Makes Use of It
the navigation of ships almost fool-proof.

and receiving "radio-goniometers." The receiving goniometer was later modified and adopted by the Marconi Co., and at the beginning of the war was considered the most developed and accurate radio compass of the day. It took a war to bring the de-

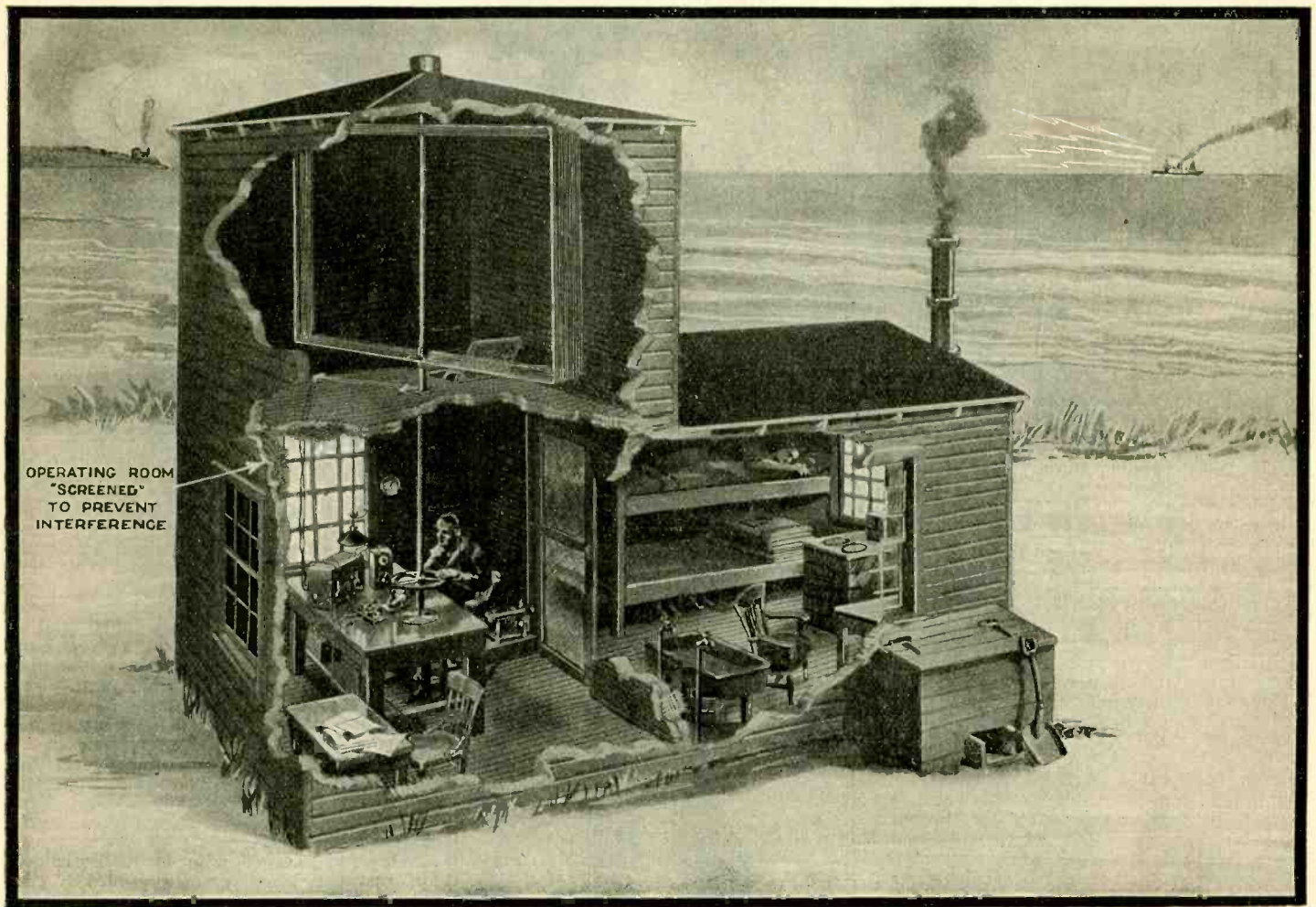

Copyright, 1919, by E. P. Co.

This View of a Typical "Radio Compass" Station as Maintained by the U. S. Navy Along Our Seacoasts is Correct in Detail and was Drawn by the Artist From Sketches of Actual Stations Furnished by the Author. These Ship Locating Stations Provide An Invaluable Service to All Mariners Approaching Large Harbors, Such as That at New York City, and the Layout of the Several Radio Checking Stations is Shown in the Map on the Opposite Page. The Loop Antenna is Swung on Its Pivoted Vertical Shaft Until the "Weakest" or Critical Sign is Heard from the Ship and the Position of the Coil, in Geographical Degrees, is Read Off the Scale and This Information Telegraphed to the Central Checking Station in New York City. When All the Stations Have Been Heard From the Resultant Information or the Exact Location of the Ship is Radioed Her Captain by the Navy Station.

unique feature of being at once a formidable aid to naval and aerial maneuvering during war-time, and war having ended, takes a prominent place as a new and valuable aid to the navigation of all maritime nations. Behold, that important and valuable instrument is—the *Radio Compass*.

It is perhaps a strange fact that this invention comes to the aid of a science which, altho a very ancient one, has changed very little in its broad fundamental principles. Modern navigation methods differ slightly from those of olden times and for that reason the radio compass may be considered as one of the first practical inventions of the day designed to aid and make

HISTORY.

Before serious attempts were made at radio direction finding, much experimenting was conducted by such pioneers as Messrs. Hertz, Zenneck, Marconi and Pickard to discover methods of directing transmitted waves in certain desired directions. That is, large metal screens were employed to deflect the emitted waves in single lines of directions; these screens or reflectors having the effect of causing little or no radiation in one direction—the maximum energy being reflected to the opposite direction. Messrs. Bellini and Tosi did their share in developing the present day radio compass by devising their so-called transmitting

vice up to its present degree of perfection, and the U. S. Navy Department, with the assistance of Dr. F. A. Kolster of "Kolster Loop" fame and other U. S. Bureau of Standards experts, as well as Lieut. C. W. Horn of the Third Naval District sector, is directly responsible for its present efficiency. The adage "Necessity is the mother of invention" proves its truth in the fact that upon the United States' entry into the war, Navy radio found itself confronted with the immediate necessity of supplying itself with accurate means of locating enemy radio stations, be they high-power long distance shore stations—which seemed to spring up like mushrooms over-

night—or raiders, submarines, etc. The result is that today the American Atlantic coast is literally dotted with groups of radio compass stations ready to aid any vessel equipt with radio, merely for the asking. The radio compass is being installed on the Pacific coast as well; and while an invaluable boon to peace-time navigation, will also prove itself indispensable during war-time by readily locating the positions of hostile warships approaching the America coasts. For, much as may be said to the contrary, there are times when war-craft are obliged to use their radio apparatus, and vigilant radio compass operators stationed along the coast will readily determine their approximate positions and courses so that effective counter-maneuvers may be directed against their approach.

GENERAL DESCRIPTION.

The radio compass is nothing more than a highly developed receiver employing a so-called "loop" instead of the usual straight antenna and ground. The loop consists of a box-cage arrangement built of light wood six feet square, upon which is wound 12 turns of insulated stranded copper wire No. 12 B. & S., gage, making all told approximately 288 feet of wire. The framework of the loop is supported upright by a long brass shaft reaching from the top of the loop to the bottom of the compass house. The two loop wires lead to collector-rings, the brushes of which further lead to the receiver, thereby enabling the loop to swing at all angles. The compass dial is installed in a stationary position convenient to the operator and has a reading scale graduated from 0 to 360 degrees, corresponding to a ship's compass. An adjustable pointer is made fast to the brass shaft supporting the loop and running thru the center of the dial; this pointer pointing to zero of the scale when the plane of the loop is pointing directly at right angles to north. This adjustment, of course, is made at the time the loop is erected.

In order to eliminate all possible magnetic influences, all parts of the loop and surrounding objects are devoid of steel or iron fittings; non-magnetic metals, such as brass and aluminum being used thruout instead. The upper and lower ends of the brass shaft rest upon bearings, making it possible to revolve the loop 360 degrees with ease. Contrary to popular belief the loop is not exposed outside of the compass house. Instead, and as will be noted from the accompanying figure, the loop is inclosed within the house and thus protected from the elements. The house or cabin is built entirely of wood and other non-mag-

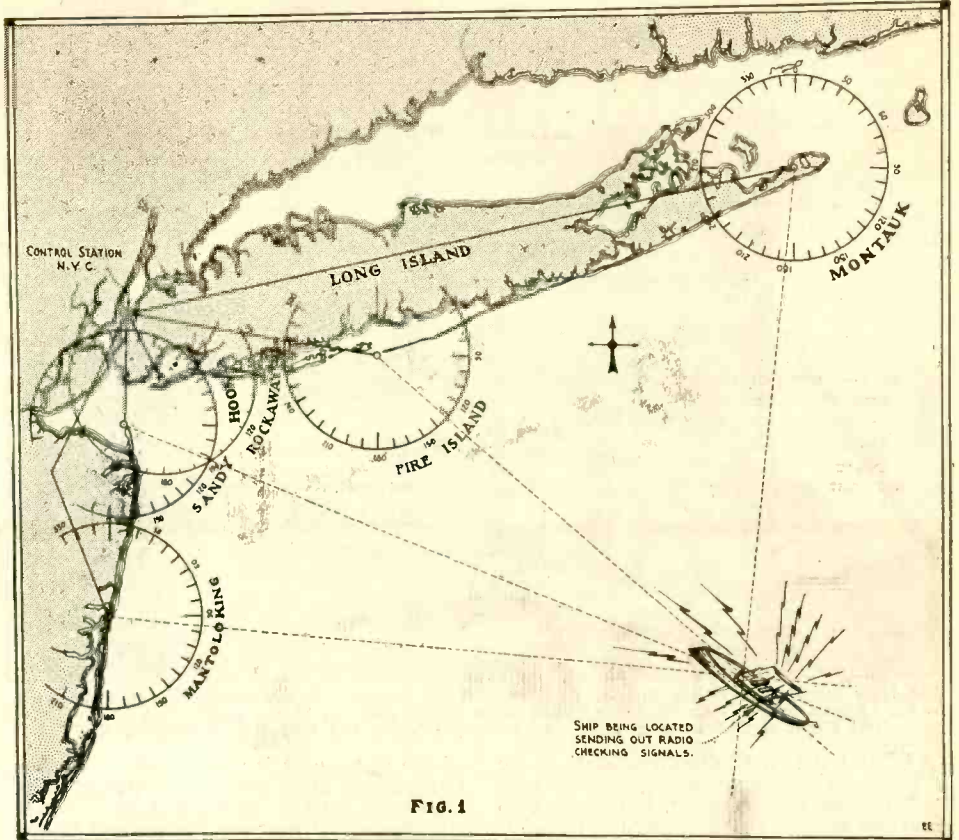

FIG. 1
How the Five "Radio Compass" Stations for Locating Incoming Ships Are Spread Out in the Vicinity of New York Harbor. Lines Drawn on the Chart From Each Station Intersect at a Point Indicating the Position of the Ship Sending Out the Signals.

netic materials; copper nails being employed thruout in construction. Unlike the regular land radio stations there is no visible external evidence that the queer looking

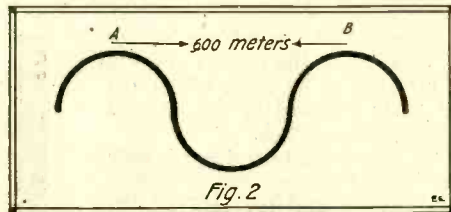

Fig. 2
Illustrating the "Wave Length" of a Radio Wave, or Oscillation.

shacks along the coast are even remotely associated with radio work.

The receiving apparatus which accompanies the loop is situated in the lower part of the room and consists of a specially

designed set having a primary, secondary, loading coil, vacuum tube connected to act either as detector, amplifier or oscillator, as well as the usual receiving appliances. Next to the receiver proper is connected a Navy-Standard type two-step amplifier with a plugging device for the very sensitive pair of high resistance telephone receivers furnished with each installation. This two-step amplifier is a very necessary adjunct when it is considered that the minimum amount of received energy is the one utilized when bearing readings are made.

The operating room containing the receiver is carefully "screened." That is to say, it is surrounded from all sides by a grounded copper netting. This precaution is necessary in order that possible stray external oscillations be warded off from the receiver, otherwise these undesirable currents would influence the receiving apparatus and render loop bearings inaccurate.

Fig. 6 is a schematic circuit diagram of the radio compass. It will be noted that no ground circuit is employed and that the loop leads are connected directly to the loading coil of the secondary inductance, instead of the primary, as is customary in other receiving circuits. No use is made of a direct-coupled one.

THEORY OF OPERATION.

In order to properly understand how the radio compass functions, it is perhaps not untimely to explain a few fundamental facts concerning its theory.

To begin with, one may as well be reminded that present day investigators have decided that the radiated oscillations from any radio transmitter travel over the earth's surface in undulating waves having a broad flat front; in other words sine waves, similar to alternating currents, shown in Fig. 2. The distance from A to B is equal to the actual wavelength of that particular transmitter, which in this case we assume to be 600 meters.

Now if the plane of the loop windings is set at right angles to the advancing wave (Continued on page 949)

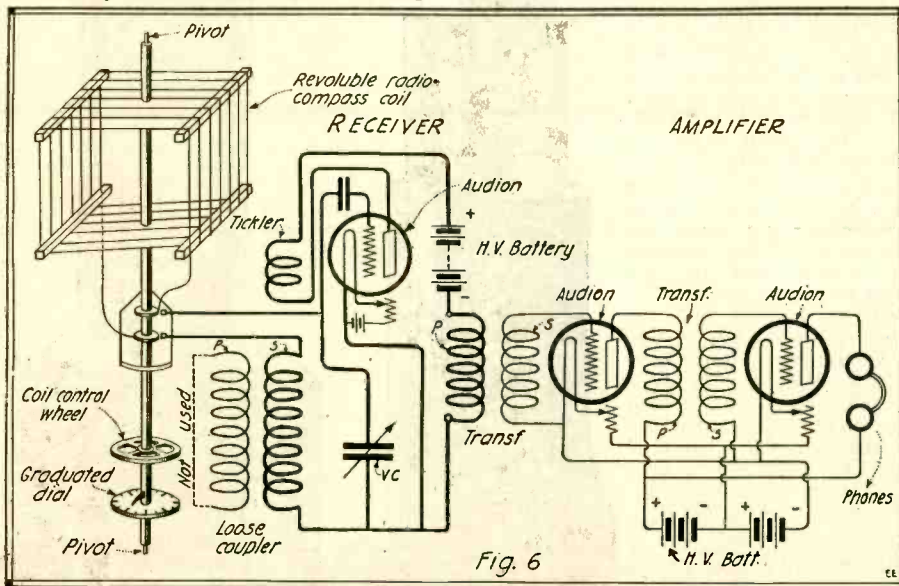
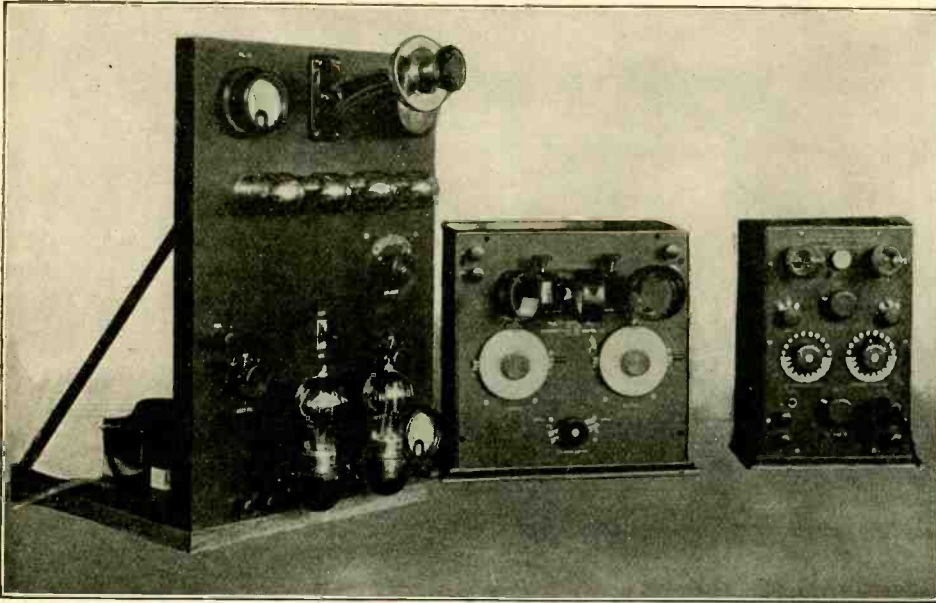

Fig. 6

The Connections Used in U. S. Naval "Radio Compass" Stations. The Details of the Loop Antenna Are Given in the Text.

An Oscillion Radio Telephone and Telegraph



The New De Forest Radio Phone, So Simple That a Child Can Operate It. It Works on A. C., Thanks to the Two Rectifier Tubes Seen at the Bottom of the Apparatus at the Left. Just Press a Button and Talk—More Simple Than the Regular Telephone, Eh?

ALTHO the A. C. Oscillion Radiophone Transmitter is something entirely new on the radio market, it has been so carefully designed and constructed that it is claimed to be a practical instrument which may be relied upon to give excellent service over short ranges. The operation

of the instrument is quite simple. All that is necessary is to connect the power leads of the set to the ordinary house lighting circuit, connect *antenna* and *ground* to the terminals of the set, push a button and talk.

The set needs to be adjusted but once.

This may be done when it is installed and once these adjustments have been made it will need no further attention. Absolutely no knowledge of radio telephony is necessary to successfully operate the set, and the non-technical man can run it just as well as the most up to date radio engineer. It is as simple in operation as the ordinary house telephone.

One of the advantages of this radio telephone which will be duly appreciated by those who have had experience with the older types is the remote control system, by which the antenna is automatically connected to either the transmitter or receiver, by merely pushing a button.

The telephone is designed primarily for 200 meter transmission, but sets can be made to operate on other wavelengths when desired. One 6-volt storage battery is needed in connection with the telephone to operate the microphone and the remote control relay. Any standard storage battery will be satisfactory for this work. Using this radio telephone in conjunction with standard receiving equipment ranges of ten miles and over may be reliably covered with a moderate sized antenna.

The panel on which the apparatus is mounted is of Bakelite 14x20 inches. It sets on an oak base 14x15 inches so that the complete set occupies a minimum of space. At the top of the panel is mounted a microphone transmitter of the usual type on an arm, to the right and left of which is located the plate circuit milliammeter and the filament ammeters respectively.

(Continued on page 954)

New Undamped Radio Receiver

Have you enjoyed the thrill of listening to the piercing whistle of the numerous undamped wave stations now operating here and abroad? Well, the pleasure is all yours, especially so as the number of stations using this method of transmission is increasing yearly, already all the Government land stations of importance are equipped for sending and receiving, while all the battleships are equipped for receiving, their transmitters being installed as quickly as time will allow.

The tone of the undamped signals can be varied from the lowest known to inaudibility; it is therefore possible to select any pitch best suited for receiving. This phenomenon is indeed interesting and in strong contrast to the spark method whose tone is fixt.

A glance at the illustration will disclose the advantages of the vertical mounting over the cumbersome horizontal method which occupies unnecessary space on the operating table, besides being harder to operate.

The principle is regenerative in action, resulting in amplification. In its construction a high grade of insulating material is used upon which are mounted all the metal parts carrying the oscillating currents. The windings are machine wound with enameled wire on substantial tubes. The compound switch permits fine adjustment on the primary inductance. The counter-balanced secondary is a unique feature which eliminates all difficulty in tuning, instantly responding to the slightest touch and remaining in any position. The balancing weight is contained in the long brass tube which permits the secondary to be loose-coupled six inches, resulting in highly selective tuning.

The set has a wave length range up to 18,000 meters on a moderate size antenna.

The detector is of the panel type, using the tubular bulb producing a pure electron

discharge. The telephone battery is enclosed in the cabinet and has a pressure of 40 volts, which can be finely adjusted by the 19-point high voltage switch.

To renew the batteries it is only necessary to remove several screws on the panel and base, thereby displacing the cabinet and making renewal easily accomplished. All connecting posts are clearly marked in white letters, these being engraved in the panel. The oscillating inductance is machine wound with enameled wire on a substantial tube fitted with a positive contact switch, which allows of sufficiently fine variation. The entire set is furnished in a mahogany-finished cabinet, all metal parts being nickelled. The height of the apparatus is 32 inches.

Loose couplers have from time to time demonstrated their efficiency in being able to tune out all those stations not desired and allowing those which the operator intends to receive from to come in with marked clarity and intensity. Many have raised objections to their use, however, stating that they were inefficient because of their coupling, but very few have been able to produce other apparatus to replace them, and which would be so universally accepted "the best ever." So it stands to reason that they are to remain.

In the Photograph Below Are Seen Two Pieces of Newly Developed Radio Apparatus Which Are Unique in Design and Construction, Having for Their Objects Maximum Efficiency and Reception of Both Damped and Undamped wave signals. A minimum Table Space Is Required. The Vacuum Tube Detector and Oscillator Is of the Tubular Type.

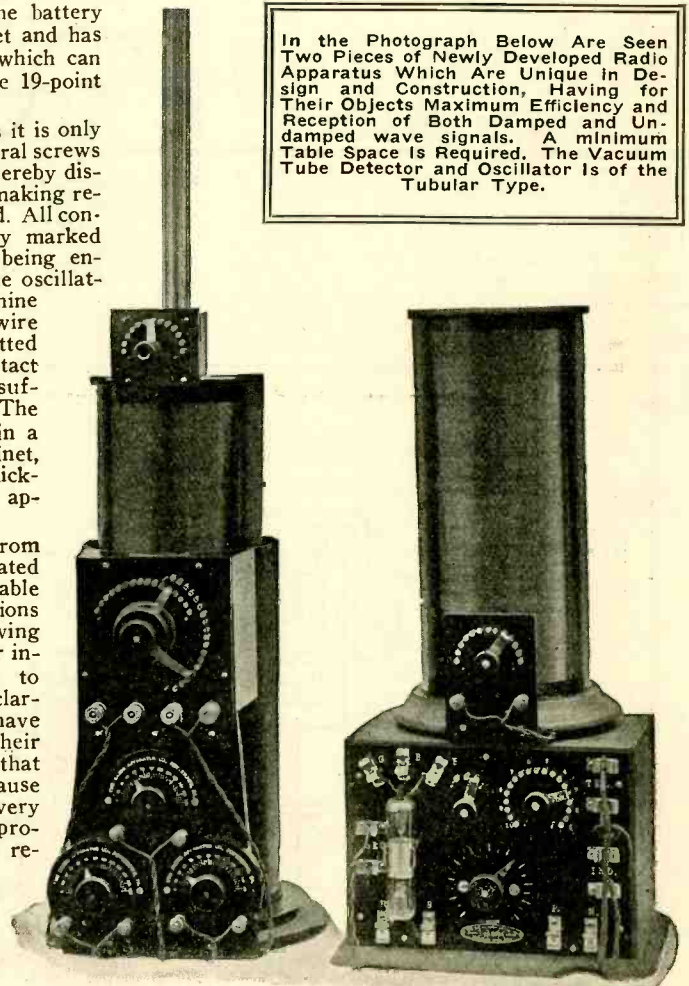

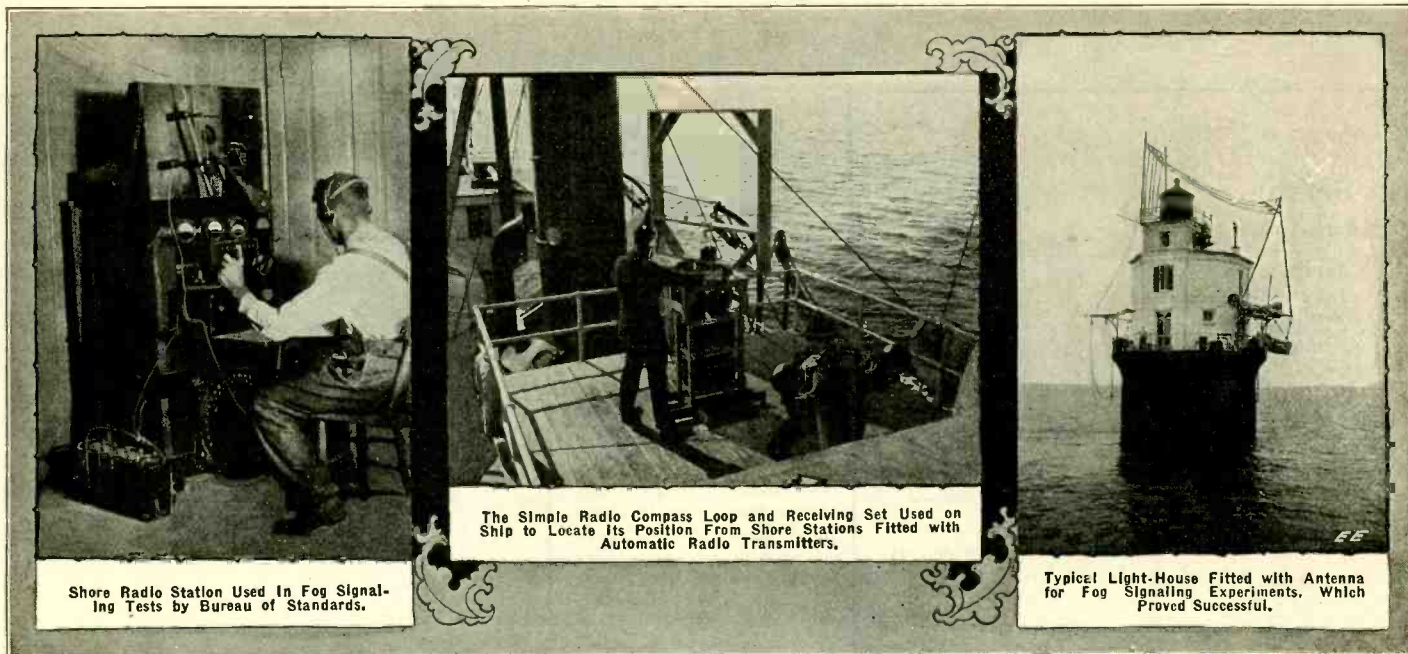

Shore Radio Station Used In Fog Signaling Tests by Bureau of Standards.

The Simple Radio Compass Loop and Receiving Set Used on Ship to Locate its Position From Shore Stations Fitted with Automatic Radio Transmitters.

Typical Light-House Fitted with Antenna for Fog Signaling Experiments, Which Proved Successful.

Radio Fog Signaling A Success

THE Bureau of Standards, of Washington, D. C., is carrying on experiments in cooperation with the Bureau of Lighthouses, to establish a radio fog signaling system. This system, when perfected, will give a navigator a reliable signal under any conditions of fog and make him independent of the lighthouse light. The principal use is the sending out of a radio signal automatically from a lighthouse and the reception of this signal upon a ship by a very simple radio direction finder. If a number of the important lighthouses on the Atlantic coast are equipt with this apparatus, the safety of navigation will be greatly advanced.

In the experiments radio transmitting apparatus were placed at three lighthouses in Chesapeake Bay, and the radio receiving apparatus and direction finder installed on a lighthouse tender. Three lighthouses are used so as to give comparative information on different types of modern transmitting equipment to determine which is the best suited for this work. The apparatus is of a special type developed by the Bureau of Standards as a result of some of its researches on radio problems during the war.

The Navy Department already has a fog signaling system under way which is, however, considerably more complicated and elaborate than the one upon which the present experiments are being made. The Navy system requires the use of several receiving stations on the shore and requires the boat to have radio transmitting equipment.

The Bureau of Standards system requires only a single radio station on shore and the ship to have simple receiving apparatus. The simplicity and low cost of apparatus required on the ship is such that it will be possible for practically every ship to be equipt and obtain the advantage of the radio fog signaling system.

FOG SIGNALING EXPERIMENTS ON CHESAPEAKE BAY

A set of experiments was made by the Bureau of Standards during September to November, in cooperation with the Bureau of Lighthouses, to test the practicability of radio fog signals from lighthouses to en-

able ships to locate their positions by use of a radio direction finder. The experiments aimed at determining the practicability of simultaneous signals from several lighthouses, the trial of automatic transmitting sets, the comparison of damped

three isolated lighthouses, each located off shore, on Chesapeake Bay, between the Potomac River mouth and Norfolk. The installation took about a month. It was found necessary to work at shorter wave lengths than had been planned, because the limited space forbade erection of sufficiently large antennas. A great many practical difficulties had to be met and overcome during the installations.

Two of the three specially designed transmitting sets were rotary gap spark sets. These gave more satisfactory signals than the third set, which utilized a large electron tube. Ample power was radiated by the electron tube set, but evidently the radio wave was not modulated in such a way as to affect the receiving apparatus used as much as the spark set. This will be investigated further.

Signals from the lighthouses were received with a direction finder on board a lighthouse tender. A four-stage amplifier, developed in the laboratory, was used on the direction finder. Experiments were made to find the best location on the ship for the direction finder. Calibrations were made to correct for the distorting effects from neighboring objects on the ship acting as receiving antennas.

Comparisons were made between the radio bearings of the lighthouses and the bearings obtained by magnetic compass and by visual observation. The radio method located the ship to better than one-half mile at fifty miles from the lighthouse, and proportionately better when nearer, which is eminently satisfactory to navigators. Difficulties connected with simultaneous operation of lighthouse stations were overcome by a time schedule of transmission. It was observed that radio waves apparently travel much more readily along the coast than inland.

It was concluded that this method of fog signaling is thoroly practicable. Radio signals sent out during fog by lighthouses can be received by any ship having a radio compass (direction finder). This is a simple and inexpensive apparatus. With this system, a ship can always determine its position with accuracy when near shore, without use of the regular ship's compass.

In January Radio Amateur News

- The Priess Loop Set—Part II.*
By Walter J. Henry
- How to Build Arc Generators*
By H. Winfield Secor
- The Design of Multiple Stage Amplifiers*
By Prof. C. L. Fortescue, M.D., E.E.
- Static Elimination*
By Greenleaf W. Pickard
- The Construction of a Radiophone*
By E. S. Rogers
- A Case of Nerves*
By Julian K. Henney
- Radio Telephone on Mount Hood*
- Designing an Amateur Transmitting Antenna*
By E. T. Jones
- Multiple Loop Aerial Switch*
By John G. Merne
- Junior Radio Section*
By W. A. Heppner

and undamped wave transmitting sets, the trial of an improved direction finder, and the determination of the accuracy of location of a ship by the radio signals.

Radio transmitting sets were installed at

New 165 Ft. Portable Radio Mast

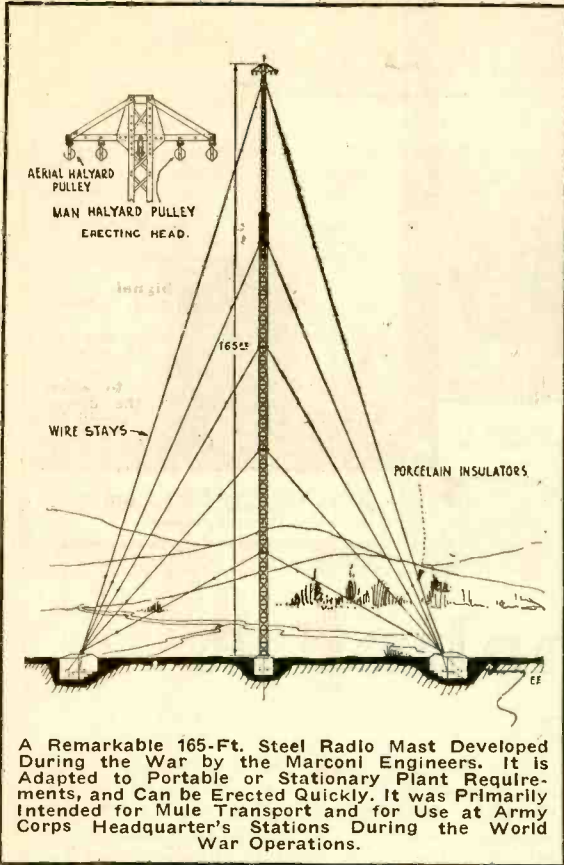

The English Marconi Company has evolved a new type of mast which has found great favor both for portable and stationary plants. It is so arranged that it may be guyed to any temporary position such as occurs with a signal corps company, or it may be used in conjunction with the main station 100 miles back from the fighting lines. This type of mast is also applicable to small commercial stations. It consists mainly of a number of steel sections with a working scaffold. The raising of these sections takes place much along the same lines as the tubular Marconi masts as used in the New Brunswick station wherein men working in this cage raise themselves a number of feet and place a small section of the mast into position and raise themselves so on upward. The mast is then guyed at points where needed as the construction goes on, and within a short time a tall but rigid mast is the finished product,—lightly constructed, but rigid.

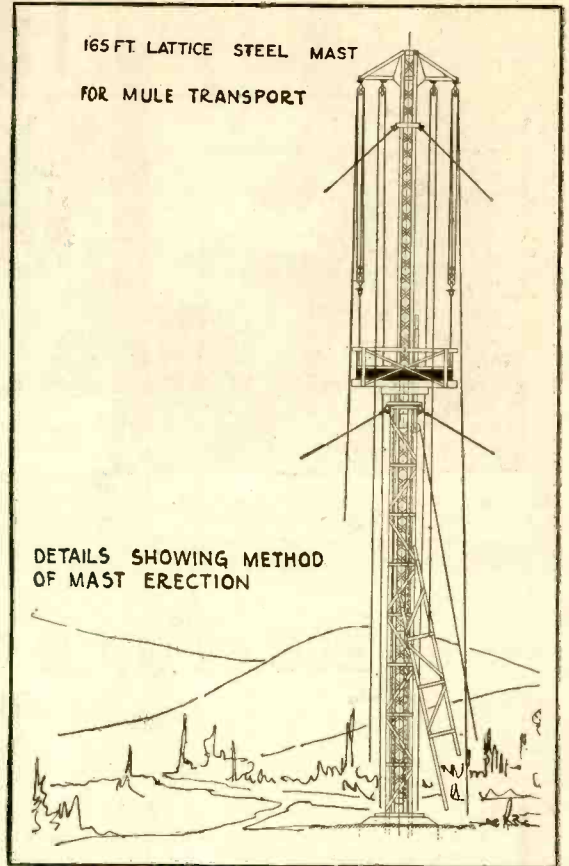

Automatic Aerial Switch

The following is a description of a very simple automatic aerial switch which I have devised and constructed and which works very well. The object of this switch is to provide means of simultaneously sending and receiving with the ordinary wireless set.

Referring to the accompanying sketch, the rotary drum carrying the embedded copper contacts H, D, E, F, and G is pivoted in the center in brass casting A. A is grounded and carries a pivoted arm with a roller contact. Casting B also carries a pivoted arm and is connected to the aerial leads.

When an ordinary telegraphic key is depressed a local circuit of D.C. is completed thru the electro-magnets I. This pulls down the armature attached to the bar, which in turn revolves the fiber wheel sufficiently to bring copper contacts G and E in contact with the aerial and ground. G.E. being the sending set aerial and ground terminals, this connects it to the aerial

and ground. It also completes the circuit thru the primary winding of the transformer by roller on C, coming in contact with H, which are in series with this circuit. This contact is not made until shortly after the sending set is connected to the aerial and ground, as can be seen by the ar-

angement in the accompanying drawing.

As soon as the key is released the fiber wheel returns to its former position, due to the adjustable spring shown, and thus connects the receiving set to the aerial and ground thru contacts F and D. The wiring diagram clearly shows how this instrument works.

There are a number of different arrangements for "listening in" while transmitting on a radio set. These include the break-in key system, having auxiliary contacts on the key, which short-circuit the receiving set, detector, etc., and then there is the Fessenden stunt of using a revolving commutator provided with a set of brushes, connected in such a way that first the transmitting set, and then the receiving set, are put into circuit successively and in rapid sequence. The experimenter will find these break-in systems worth while studying, for they are the coming thing in all modern radio stations, both amateur and commercial.

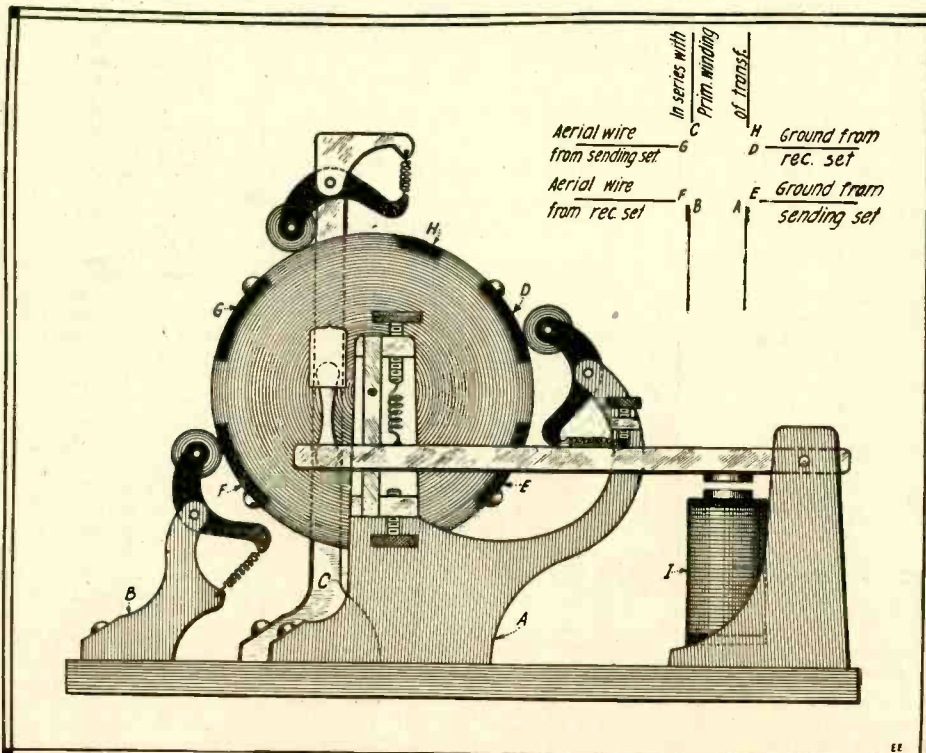

A Design for an Automatic Aerial Switch Intended to Provide Means for Simultaneously Transmitting and Receiving Radio Messages.

Contributed by
ERNEST OKE.

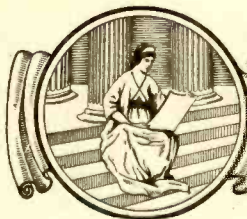

LATEST PATENTS

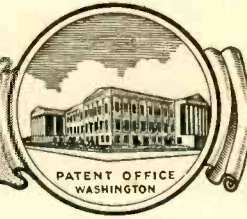

Wave Motor.
(No. 1,318,469, issued to John F. Wilkinson.)

This invention covers a means for utilizing the rise and fall as well as the lateral surging movements of tidal waters, for produc-

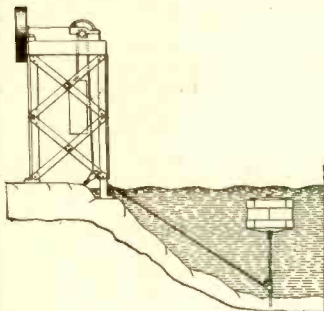

ing power. Considered as a unit, of which any number may be used of course, there is a primary power cable attached to and partially wound upon the main shaft. Attached to the outer end of this cable is a hollow air-tight float. As the tidal or other movements of the water occur, the float naturally moves in or out, or up and down, and transmits the power thus gained to the main power shaft thru a special clutch, which causes the power from the float cable to be transmitted to the machinery in a unidirectional or continuous form, no matter which way the cable moves,—inward or outward.

Electric Riveting.
(No. 1,322,848, issued to E. Jannez von Henke.)

An improved technique and method of applying electric riveting to sheet metal, particularly heavy plates. As the drawing indicates, there is provided an annular contact block, electrically connected with the transformer secondary,

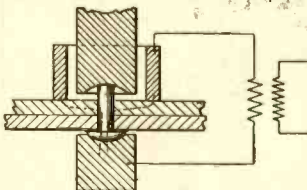

while a second electrode is placed under the rivet as shown. As the rivet blank is inserted cold, it can be given a tight fit within the holes in the plates, so that when the circuit is established, a heavy current will flow from the top contact block, thru the plate, across the joint between the rivet shank and the wall of the hole, thence thru the rivet shank and thence to the lower contact block.

Transformer Protector.
(No. 1,317,767, issued to C. H. Thordarson.)

This idea aims to provide a protection in transformers between the low tension winding and the high tension winding. The inventor proposes to connect the coils of the low tension winding with the low tension current source, and to a

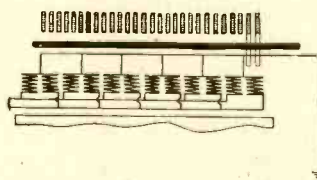

grounded conductor, in such a manner as to prevent destructive stresses or surges being set up in the low tension winding, due to ex-

cessive surges thrown on the high tension winding. He further aims to provide an efficient electro-static shield between the high and low tension windings, also an arrangement of the low and high tension windings such that in a ratio transformer, the voltage of the high tension winding is maintained straight, and the low and high tension windings are automatically balanced.

Combined Telephone and Phonograph.

(No. 1,323,710, issued to John F. Malthaner.)

A very clever invention whereby a "dictaphone" may be used for recording ordinary telephone conversation, or else employed in the regular manner, as may be desired. In other words, the inventor provides a unique scheme whereby telephone conversations may be recorded upon the record cylinder of a commercial dictating machine, so arranging the electrical circuits that under ordinary dictating conditions, cer-

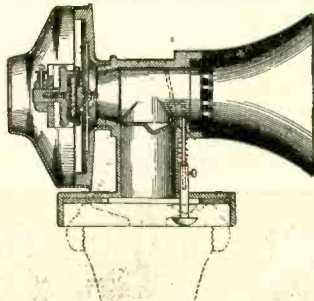

tain parts of the apparatus used for receiving and transmitting telephone messages may be used by the dictating machine. The dictating machine has only to be slightly modified, and fitted with a small electro-magnet so as to be operated by the telephone currents. In order to avoid any objections of telephone companies, no mechanical or electrical connection between the telephone proper and the recorder or dictaphone is necessary.

Telephone Receiver.
(No. 1,321,171, issued to Maximilian Weil.)

A scheme for utilizing aural receivers in conjunction with the usual telephone and in which

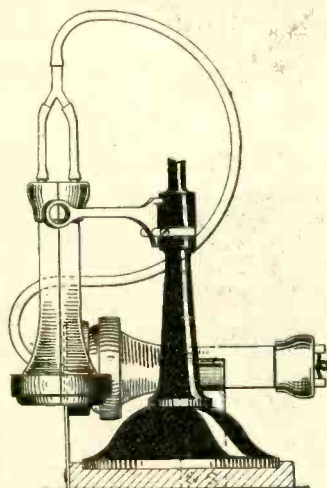

scheme the usual electro-magnet receiver is supported in a guide or support on the base of the instrument in alignment with an acoustic receiving chamber. This acoustic receiving chamber communicates with a special form of aural receiver, which is held to the ear or ears. The sound waves are trans-

mitted thru a rubber tube and in one form of the invention, the aural receiver is made in two halves, which may be separated and one half held to each ear.

System of Acoustic Signaling.
(No. 1,320,686, issued to John Hays Hammond, Jr.)

Relates particularly to a method for transmitting signals of varying

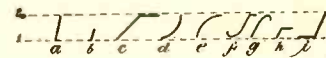
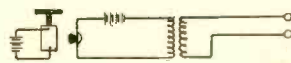
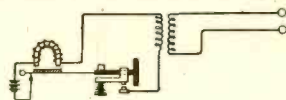

characters, such as pitch and intensity, and receiving and interpreting them, so that they will produce characteristic tones or visible characters. These audible or visible characters form a telegraphic shorthand system. A transmitter may be used, capable of producing variable tones ranging in frequency from 200 to 500 per second, for example. The intermediate frequency changes may be made as slowly or as quickly as desired; thus a character such as shown at A, may be transmitted by starting with a frequency of 200 per second—raising it as quickly as possible to 500 per second—and then cutting it off.

Electric Ship Detector.
(No. 1,319,145, issued to Reginald A. Fessenden.)

Professor Fessenden's scheme here shown, covers the detection and location of ships and other



marine bodies, particularly when an approaching ship is located over a mine and in such a position that it will be exploded if the mine is detonated. The device proper comprises a large diaphragm, which the inventor has found very sensitive to distant sounds, and on the inside of this diaphragm there is mounted an inertia type carbon microphone, such as the Skinderviken.

Musical Composition Scheme.
(No. 1,323,218, issued to Thomas A. Edison.)

This scheme devised by Mr. Edison, relates to the rendering of musical compositions by a plurality of players, such as an orchestra, and is arranged so as to provide a method for enabling the various players to maintain uniform pitch and tempo while jointly rendering a composition. The orchestra in this

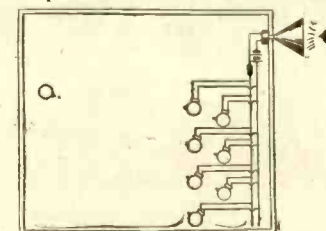

case has to be supplied with an auxiliary leader, who is a master

artist or player and termed the "pitch leader". The rendition of the master artist or player is telephonically and also individually transmitted to each player of a stringed instrument in the orchestra.

Electric Auto Signal.
(No. 1,317,906, issued to J. J. Benedict.)

A novel device which may be used night or day on the rear of automobiles to warn the driver of a vehicle in the rear as to when and in what direction the driver ahead intends to turn. As will be observed, the signal is in the form of a human hand and an electric light mounted on it, makes it readily visible at night, so that any movements of the signal will be at once noticed. The lamp on the sig-

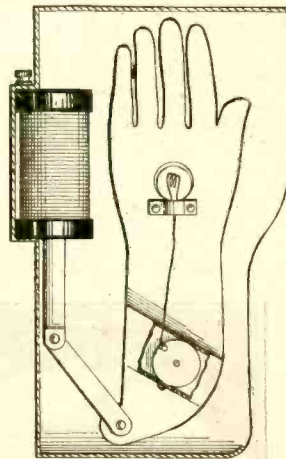

nal is not lighted when the signal is in the normal condition. The hand or semaphore is operated by an electric magnet or solenoid; this solenoid being operated from the car battery by means of a push button conveniently located.

Sound Transmitter and Receiver.
(No. 1,321,197, issued to H. J. W. Fay.)

An improved device for the transmission and reception of sound waves thru water. It comprises a device analogous to a telephone receiver with such structural changes as will adapt it when used as a transmitter to produce a maximum of mechanical vibrations with a minimum of electrical energy to cause said vibrations, as the telephone

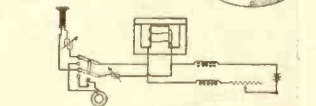
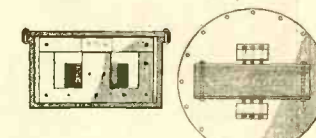

receiver may convert mechanical vibrations, such as sound waves received thru the water, into electrical energy, and such electrical current when used to actuate a telephone receiver, will enable one to detect vibrations of very minute intensity. When used as a producer of sound waves in water, a source of high frequency alternating current is employed. The frequency of this current should be equal to the natural mechanical period of the diaphragm. The value of the condenser in the circuit is adjusted until the power factor of the current flowing thru the helix is substantially unity.



WITH *The* AMATEURS

Our Amateur Laboratory Contest is open to all readers, whether subscribers or not. The photos are judged for best arrangement and efficiency of the apparatus. To increase the interest of this department we make it a rule not to publish photos of apparatus unaccompanied by that of the owner. Dark photos preferred to light-toned ones. We pay \$5.00 each month for the best photo or photos and \$2.00 to each "Honorable Mention." Address the Editor, "With the Amateurs" Dept.

"Amateur Electrical Laboratory" Contest

**THIS MONTH'S \$5.00 PRIZE WINNER—
R. N. RHODES**

THE accompanying photos are views of my electrical "Lab." I have been for a number of years a close student of electricity. I am sixteen years of age, a high school student, and greatly interested in the scientific arts. I have seven different kinds of motors—one an induction motor, volt-ammeter, test tubes, electric bells, all kinds of copper wire, and small electrical fittings, etc. The electrical division contains among other things, 50 watt step down transformer, a four magnet generator which I use to test coils, lights, etc., and have lots of fun using it for a "shocking machine." Among the home-made apparatus are:—an electric stove, a rectifier to change A.C. to D.C. and charge small storage batteries, also an arc light, and polarity indicator. I have also a collection of miscellaneous articles, commonly known as "junk." The usual collection of "miscellaneous" comprises telephone parts, coils, binding posts, aluminum, and other numerous accessories. I also have tools of all kinds, hand drill, gasoline blow torch, etc. The static machine is of the Wimshurst type. I made this machine out of two seven-inch grafonola records and with brass fittings that are found in every Amateur's work-shop. It has sixteen tinfoil sectors on each plate and is insulated from the frame by rubber covered knobs.

In the photo to the right can be seen my cabinet, which I made to hold small articles. It has 75 drawers, made of cigar boxes. The drawers are properly labeled. To the right of it is my home-made book-case, and I have 44 scientific books, as well as files of Popular Mechanics, the ELECTRICAL EXPERIMENTER, and "Hawkin's Electrical Guides."—R. N. Rhodes, Fordyce, Arkansas.

**HONORABLE MENTION, ANTHONY MAG
\$2.00 PRIZE PAID EACH "HONORABLE MENTION"**

I HAVE a large portable garage for my "Lab," and have gas and electricity installed therein. In my electrical section, I have a large grinding machine with three grind stones of various sizes and coarseness attached to it. This machine is run by a 1/4 H.P. motor. I also own a large work bench and strong anvil vice. On the right of this bench can be seen my switchboard which controls the motor, lights, transformers, etc. On my bench are seen a number of generators, motors, a circuit breaker, two transformers, one storage battery, and various tools. Here I construct apparatus which I often sell and trade. On the shelves I have resistances, three ammeters, two voltmeters, galvanometers, wire, tinfoil, lamps, a lamp bank, switches, static electricity apparatus, electroscopes, receivers, transmitters, buzzers, bells, electrolytic interrupter, Leyden jars, glass plate condensers, step-up transformer, two telephones, et cetera.

In my chemical section, I have over two hundred and fifty chemicals and a great deal of apparatus, such as ring stands and rings, a large microscope—which is invaluable to me, a large gas and electric furnace, beam balance and weights, condensers, flasks, beakers, evaporating dishes, test tubes, test papers, graduates, pipettes, blow pipes, sand baths, etc. Under my microscope I test cloth, etc., and the chemicals that I make, I test and sell.

A book case and desk add to the many conveniences of the "Lab," and it is here that I do all my writing and calculating. I have a number of mechanical drawing instruments and I develop and print my own photos. I also have electrical, chemical and wireless books.—Anthony Mag, 4212 Penn Ave., Pittsburgh, Pa.

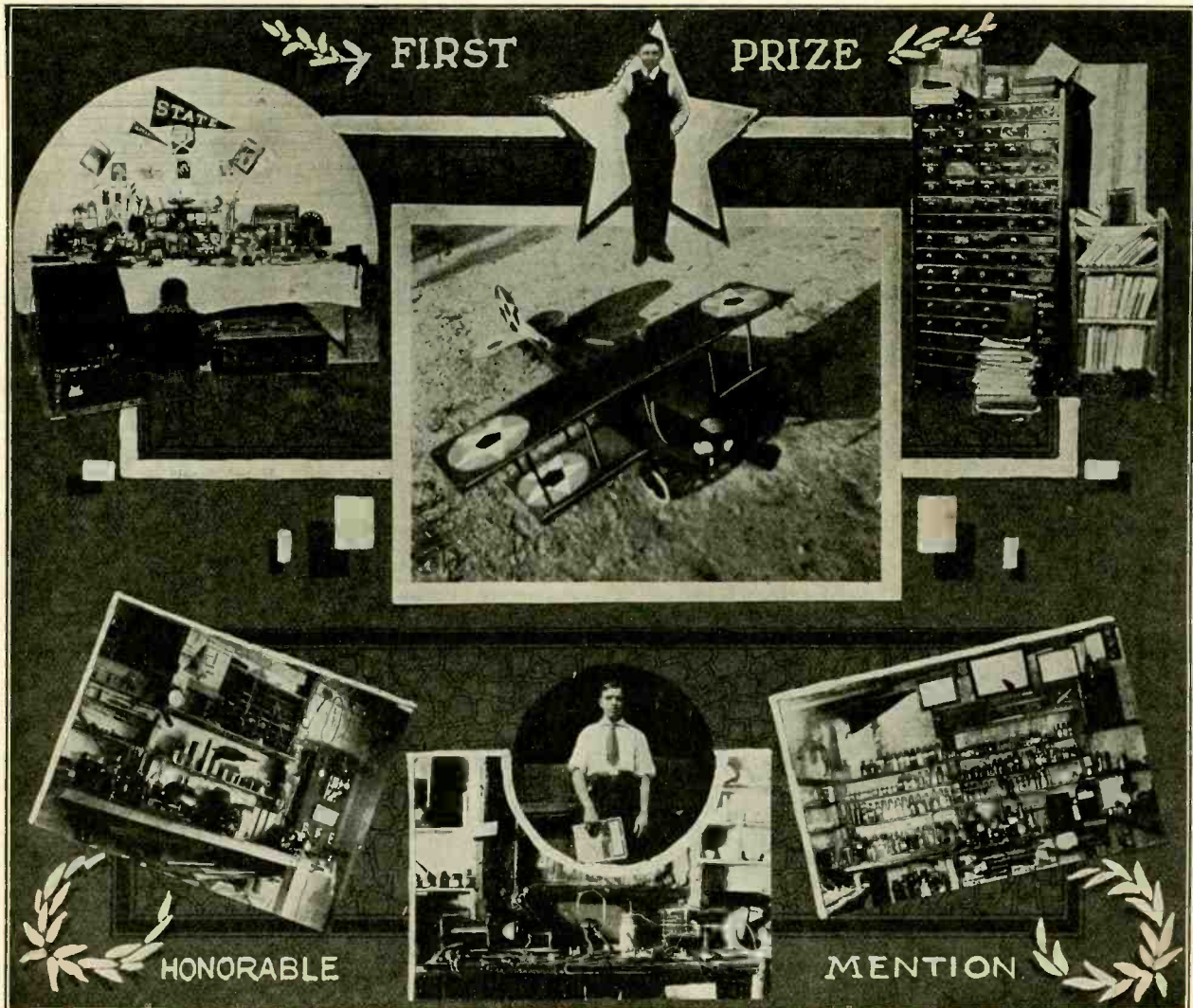

Science in Slang

By EMERSON EASTERLING



“HE Great White Way!” We had just turned into that modern accomplishment of the great God Obdura Mazda, and Bender had let loose with a young yelp.

“And we owe it all to Tommie Edison,” put in Punk.

“If you want to have it that way,” interposed a voice—and a body also interjected itself in between the members Punk and Bender.

“What the ——!” I exclaimed, seeing Jazz Stokes, “I thought you were at the power plant seeing the watts wattle along the wires.”

“I was,” he returned. “But I had to see the silk legs for a change—so I dropt down to the little metrop.”

“We have nothing to do now but walk down to the theatre—we’ve gone on a strike with the cab drivers, I mean we walk—so let loose with some of your bull and enlighten us about the in(can)descent light stuff. I’m dark on the subject,” Punk rambled along.

“Yes,” put in Bender. “Get back to the very beginning. This bird Thade here is writing your palaver up for the ELECTRICAL EXPERIMENTER, and the darn fool seems to be getting away with it.”

“Well,” began Stokes, “to be real historic, our friend Sir Humphry Davy way back in 1810 in the Jack Ox country pulled the first boner in the electric light stuff when he heated a platinum wire until it glowed out the primeval electro-spectro-radiation. It was primary stuff; any kid does it now—but, get the point, it was the *first* stuff in that line.

“When we discuss the practical electric light we stick up Tommy Edison as the *old man*. He had a lot of guys in his laboratory carbonizing everything around the place that could be made into a filament—why, he had a bunch of hoosiers galloping into the wilds of India and South America in quest of the elusive bamboo specie—he figured that bamboo was the stuff for the filament in his new impossibility. He would get a light about assembled and — whoof! she would go fluey!—he mopped his dome, gave a verbal recitation in slang, and began at the first act with the tragedy again. If at first you don’t succeed, etc. He didn’t write that. He executed it. After some forty seven fizzles he had the luck to get the juice squirting through his model of what the candle gave way to.

“For forty-eight hours he, and some of his attendants, sat gazing at the red-white glow on the wires and he seeing in it what

Light on Electric Light

we witness along this thoro-fare; finally, they satisfied themselves that the thing had ‘got on’ and that they had gotten away with their stunt and so they hit the pad for the big snooze that they had neglected. When they rubbed their orbs after the series of selections at nasal delivery, they saw that the light still burned. It was the light that

thing. This was way back in 1882. Today—but you can see for yourself.

“For a long while before Edison came around with his impossibility, the public spraddles around in the flickering flare of the old arc lights. We had the great minds like Gramme, Thomson, Houston, both singly and combined, to be thankful to for the flickerers. Gramme is guilty for the reason for the arc lights on the corners and such guys as Brush and the others for the lights themselves.

“Edison had the right idea when he took out his patent. If you should investigate you will find that it covers the whole system of generation, distribution and what else he could stretch it to mean. He got a blanket patent, all wholesale, no retail either. He did not patent the light alone, to reap the millions off it. He patented the system, to reap billions from.

“A young American over in England, in 1845, got out a joke patent on the light question. We might have heard from the chap in other lines but he kicked the old oaken tub at the age of twenty-five—so —

“In the old days before the transformer transformed the D.C. to A.C. we —

“Say,” I interrupted, “but you put us wise to that a couple of issues ago and I have to have new junk or the space will be taken up with ‘How to convert junk into wireless apparatus’ or ‘What I did with MY old buzzer’—get the idea?”

“Pardon me, Emerson, but we will then indulge in the subject of lights, electric, and those caused by electricity: firstly, we have two kinds—what? No, not *good* and *no good*. We have the arc and the incandescent—that is mainly—a vapor light is in reality an arc of great length—perhaps you think differently.

“In the arc class we have the Carbon arc, the flaming arc (carbon) and the same in both the open and enclosed type and the magnetic and mercury arcs and the quartz eradicators of darkness; also they come in the glass variety, all sizes and half a dozen colors; six shades of the colors around the high speed end of the spectrum. To be explicit: three tones of violet and three of the same with spasms of green and yellow.

“Cooper Hewitt is the guy who gets most of the credit for the vapor type as he gassed the world in the movie realm when he sneaked in and set up his brand of the artificial daylight and made it possible for the directors to get in on the night shift at the studio.

“When we get onto the incandescent type we have to dwell on the first dim carbon lamp made from grandma’s old shoe lace

(Continued on page 933)



“When We Discuss the Practical Electrical Light, We Stick Up Tommy Edison as the OLD MAN. Why He Had a Bunch of Hoosiers Galloping into the Wilds of India and South America in Quest of the Elusive Bamboo—for he Figured that Bamboo Was THE Stuff for His Lamp Filament. It Was! Tom then Gussed that If the Gas Companies Could Pipe Gas Around and Peddle it to Unsuspecting Consumers—Why Couldn’t He Do the Same With Electric Juice? He Did, You Betcha!”

never failed. And we still have it.

“From that day on Tom has had his finger in the light game. It started when he figured that if the gas companies could pipe gas around and peddle it to unsuspecting consumers—why couldn’t he do the same with the juice?”

“He could and did, you betcha!”

“Working with this in mind he constructed the Pearl Street central station with the big clumsy generators and every-



THE ORACLE

The "Oracle" is for the sole benefit of all electrical experimenters. Questions will be answered here for the benefit of all, but only matter of sufficient interest will be published. Rules under which questions will be answered:

1. Only three questions can be submitted to be answered.
 2. Only one side of sheet to be written on; matter must be typewritten or else written in ink, no penciled matter considered.
 3. Sketches, diagrams, etc., must be on separate sheets. Questions address to this department cannot be answered by mail free of charge.
4. If a quick answer is desired by mail, a nominal charge of 25 cents is made for each question. If the questions entail considerable research work or intricate calculations a special rate will be charged. Correspondents will be informed as to the fee before such questions are answered.

ONE FILAMENT BATTERY FOR TWO AUDIONS.

1033) Joseph R. Matteson, Philadelphia, Pa., asks:

Q. 1. Give diagram for using a common filament battery and two audions.

A. 1. Herewith is a hookup showing how to use a 9,000 ohm auto or a two-coil transformer, with an iron core, so that one storage battery will light the filaments of two audion bulbs. The diagram clearly explains connections.

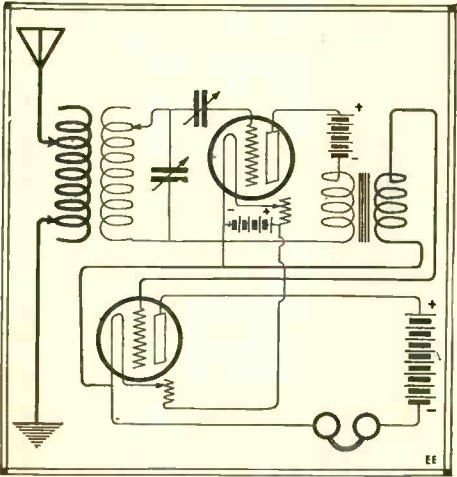

Circuit Employing Common Battery for Two Audions. A Common Battery for the Plate Circuits of Two or More Audions is Quite Common.

ELECTRIC SPARKS FROM WATER AND GAS PIPES.

(1034) H. L. Allen, Jr., Arctic Center, R. I., writes "The Oracle":

Q. 1. Stating a peculiar case where electric sparks were obtained from a gas pipe and a heating furnace, in the same house.

A. 1. With reference to the peculiar electrical problem you describe, as near as we can judge from the meager details given, the spark obtained between the gas burner and the base of the heater in the house in which there was no electrical installation of any kind, undoubtedly can be accounted for by electrical leakage currents or straight ground currents. The electrical railway and trolley systems are particular offenders in this direction, and there was a case similar to this one on the outskirts of an Eastern city some years ago, where sparks such as you describe occurred, and where there was no electrical installation or wiring for over a quarter of a mile. It was possible to light a 110-volt lamp by connecting the lead wires to the water-pipes.

This peculiar phenomenon was finally accounted for by the fact that one of the trolley feed cables had broken down, thus causing a large part of the current thru the main line to pass thru the ground, adjacent to the trolley system.

Poorly bonded trolley or electrical railway tracks also cause this trouble in many instances. The heavy return current which normally is supposed to pass thru the rails to the power house being unable to negotiate the high resistance fish plate, joints at the junction of the rail sections, hence leaking away thru the ground and causing very serious disturbances in many cases.

In this same direction another peculiar incident may be mentioned where a trolley

WANTED!!!

"ODD PHOTOS" AT \$1.00 EACH

Here's what we want! What have you got?

ELECTRICAL PHOTOS—

New photos of Lightning; new and unusual Electrical Apparatus and Machinery; Electric Signs; Electric Autos; Electric Clocks.

SCIENTIFIC PHOTOS—

New Scientific Apparatus; Results; Effects; Motion Pictures; Stunts.

OPTICAL PHOTOS—

Peculiar stunts obtained with various lens arrangements; odd film effects caused by unusual conditions; novel micro-photographic subjects.

ASTRONOMICAL PHOTOS—

New eclipse photos; star and moon effects caught by the camera; comets; shooting stars; progressive moon studies; moon and star photos.

FREAK PHOTOS—

Odd double and triple exposure effects; novel and striking effects due to unusual exposures.

MECHANICAL PHOTOS—

Electrical and Mechanical apparatus of unusual news interest.

RADIO PHOTOS—

New stations, both commercial, government, and private. Owners of private or amateur stations will find a special contest for these photos on another page of this issue.

And don't send us plate or film "negatives"; send unmounted or mounted "prints", preferably a light and dark one. Enclose stamps if photos are to be returned and place a piece of cardboard in the envelope with them to prevent mutilation.

Address photos to—Editor "Odd Photos", Electrical Experimenter, 233 Fulton Street, New York City.

feed cable or auxiliary feed wire broke down, causing a heavy current to pass thru the ground to the trolley rail or return circuit, and a team of horses approaching the trolley crossing at this point were instantly killed by the difference of potential created when they rested their front feet on the trolley rail, while their hind feet rested on the earth. This may seem a little peculiar

at first thought, but it is well to remember that the ground is not a very good conductor, especially in small areas. If you have ever stood on the ground with ordinary nailed-sole shoes, and touched an electric light socket or live wire of 110 to 220 volts potential, you have undoubtedly found that you will get a very strong current thru the body, and if the ground happens to be damp, the stronger the current received. Also if the shoes are damp, you will get a stronger current than if they were dry. On a perfectly insulated electrical distribution system, you should not receive a shock by touching one side or the other of the live circuit, and while in contact with the ground thru your shoes, but if the system is grounded on one side (or it may be grounded as in the three-wire system for lightning protection), then, of course, when touching one of the live wires of the proper polarity, you will form a complete circuit thru your body down to earth and thru the soil, back to the grounded conductor connecting to the other side of the circuit.

The problem of electrolysis is a large one and is engaging the attention of all city engineers, for these stray currents play great havoc with the buried metal pipes and conduits forming the water and sewerage system of cities. A stray current will often pass from a poorly bonded railway track to a metal pipe line; where this current leaves the pipe, it carries some of the metal along with it, thus slowly decomposing the pipe. Some of these pipes are so riddled with holes as to be veritable sieves, when they are finally located and unearthed. The trolley companies have to keep constant watch on the copper cable or wire bonds joining the ends of their trolley rails, for these reasons.

DYNAMO VOLTAGE QUERY.

(1035) A. L. Haynes, Clifton, Kansas, writes the Oracle:—

Q. 1. With reference to a transformer for boosting the voltage of a D.C. dynamo while it is accelerating.

A. 1. Concerning data for a small step-up transformer to be used on a direct-current generator, would say that this is impossible, as a transformer must be operated on alternating current in any case.

The best thing you could do in this direction, probably, would be to arrange the field winding on your machine so that the field coils could be connected in parallel, while the machine is accelerating, and in series after the machine had attained normal speed. This will have the effect of causing the field coils during the acceleration period to take more current, thus producing a stronger field, which in turn would produce a higher voltage in the armature. Later, when the machine had attained normal speed, a specially arranged quick-throw switch could be utilized to throw the field coils in series, causing them to take less current and to produce a normal field strength.

Why Electrical Workers Are Needed.

Consider for a moment what part electricity plays in every-day life, in the comfort, convenience, pleasure and even health of the whole civilized world.

Think of having to ride in horse cars again—

of writing a letter every time you now phone—

of waiting days for what the telegraph does in a few minutes—

of no automobiles or moving picture shows—

Electricity takes millions to and from work. Without it the automobile and airplane would be impossible—the telephone and telegraph would be useless. All the civilized world relies on it for light, heat, transportation and communication. In a thousand ways electricity is used in factories, offices and in the homes.

Electricity is almost as essential as the air we breathe. Business would be almost at a standstill if deprived of its energy.

To say that electricity is still in its infancy is no exaggeration. Every day brings into practical use some new method of controlling it, some new device or appliance for using it. In industrial work there are still scores of operations where electricity will be utilized sooner or later. The day is coming when the railroads will entirely replace steam with electricity. Doctors, dentists and scientists are only beginning to realize the possibilities of electrical energy.

These facts merely touch the high spots, yet they prove beyond a doubt that electricity plays a vital part in business, in our individual lives, and that there is unlimited scope for those who make electricity their life work.

The electrical worker provides other men light to work by, the telephone and telegraph to convey their orders, the power to run their machines and transport their goods. He supplies power in the homes to operate washing machines, vacuum cleaners; for ironing, heating and ventilating. In short, it is the electrical worker who makes it possible for the world to live more comfortably, to enjoy more pleasures and to do a bigger, more profitable business.

Try to realize just what it would mean if the world were deprived of this wonderful energy and you will have a better idea of its importance and understand why the electrical worker is *always* needed.

What Electricity Offers You

Once you have mastered the A-B-C of electricity you are confronted with unlimited opportunities for advancement. You can specialize in extending and perfecting the wonders already accomplished in the field. You may take up those branches of electrical and mechanical work which cover the design and manufacture of electrical apparatus or start in to qualify for a well-paid position in the designing, construction, operating or consulting branches of the electrical engineering profession, and to fit yourself eventually for a position as Distribution, Operating, Testing, Erecting or Designing Engineer.

In the automobile, airplane, telephone and telegraph lines there is also great scope for the trained electrician. Many wonders of electricity have yet to be unfolded—its uses multiplied—and opportunities still greater for those who can qualify.

With all these indisputable facts—things you absolutely know to be true—can you doubt for a moment that in choosing electricity for your lifework you are making a wise choice?



How You Can Qualify

You don't have to interfere with your present work while qualifying for a good electrical position. The American School can give you just the training you need in your SPARE TIME. Our electrical courses have been specially prepared for home study—are written so you can understand everything quickly—and from your first lesson until you get your Diploma expert instructors coach you. Our training will enable you to get into the game RIGHT.

Read This Guarantee—Then Act

"We guarantee at any time during the first year of your enrollment to refund the entire amount paid if, immediately upon the completion of ten examinations, you notify the School that you are not satisfied with your course."

AMERICAN SCHOOL OF CORRESPONDENCE
Dept. G 261 CHICAGO

TRAINING—THE KEY TO SUCCESS
Please send me booklet and tell me how I can fit myself for the position marked X

- .. Electrical Engineer
- .. Electric Light and Power Superintendent
- .. Hydroelectric Engineer
- .. Wireless Operator
- .. Mechanical Engineer
- .. Heating and Ventilating Engineer
- .. Sanitary Engineer
- .. Master Plumber
- .. Civil Engineer
- .. Structural Engineer
- .. Western Union Course
- .. Telephone Engineer
- .. Draftsman and Designer
- .. Automobile Engineer
- .. Automobile Reprisman
- .. Airplane Mechanic
- .. High School Course
- .. Architect
- .. Building Contractor
- .. Lawyer
- .. Business Manager
- .. Certified Pub. Acct't
- .. Accountant and Auditor
- .. Bookkeeper
- .. Gen'l Education Course
- .. Com. School Branches
- .. Fire Insurance Adjuster
- .. Shop Superintendent
- .. Steam Engineer
- .. Stenographer

Name.....
Address.....

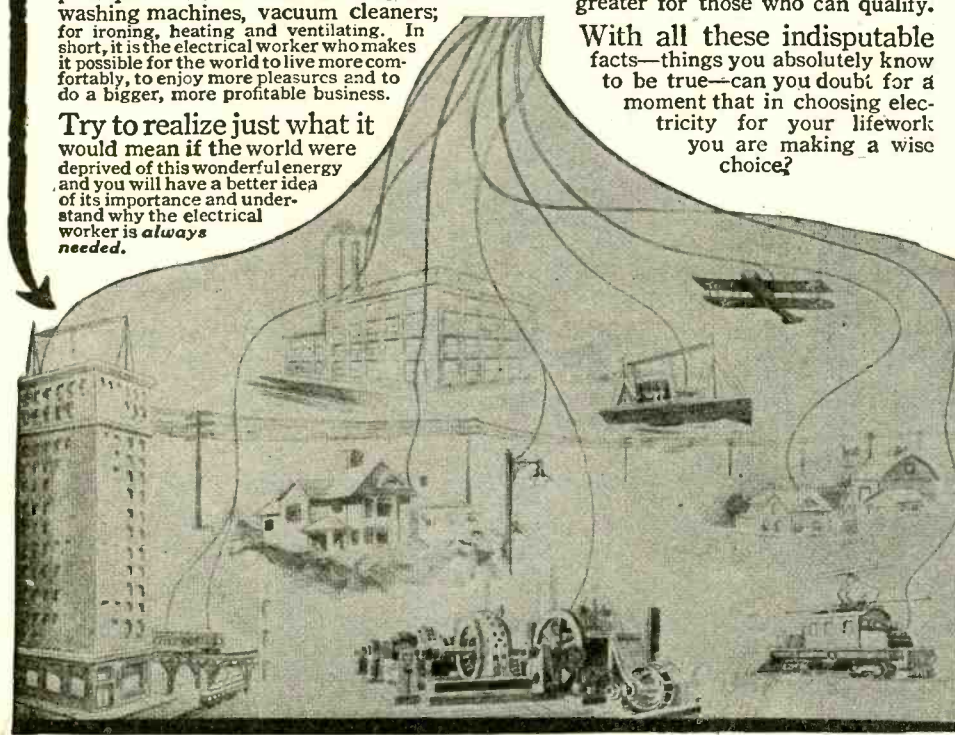

BE AN EXPERT



Auto and Tractor Mechanic
Earn \$100 to \$400 a Month

Young man, are you mechanically inclined? Come to the Sweeney School. Learn to be an expert. I teach with tools not books. Do the work yourself, that's the secret of the

SWEENEY SYSTEM
of practical training by which 5,000 soldiers were trained for U. S. Government and over 20,000 expert mechanics. Learn in a few weeks; no previous experience necessary.

FREE Write today for illustrate or catalog showing hundreds of pictures men working in new Million Dollar Trade School.

LEARN A TRADE

Sweeney

SCHOOL OF AUTO-TRACTOR-AVIATION
66 SWEENEY BLDG. KANSAS CITY, MO.

AN EASY WAY TO MAKE MONEY

Don't be content to plod along on a small salary. Be independent. Go in the tire repairing business. One man says "I made \$60.00 the first day." Others average \$200 to \$500 a month. Very little capital needed. Jobs plentiful. Every motorist a possible customer. No experience needed. We teach you.

SHALER Tire Repair Outfit

Improved Wrapped Tread Method
Used by Tire Manufacturers



Does as good work as the big high priced vulcanizing outfits. A boy can use it. It's the only vulcanizer that has Automatic Heat Control, and can't undercure or overcure a tire. Requires no watching or regulating.

FREE Book
"How to Open a Tire Repair Shop." It tells how to make big money. Don't delay. Write quick.

C. A. SHALER CO.
2209 Fourth St. Waupun, Wisconsin

SLIGHTLY USED TIRES STANDARD MAKE

Size	New Tube	Price	Size	New Tube	Price
30x3	.. \$1.85	.. \$ 4.50	33x4 1/2	.. \$3.00	.. \$10.25
30x3 1/2	.. 2.00	.. 5.00	35x4 1/2	.. 3.50	.. 10.50
31x3 1/2	.. 2.25	.. 5.50	35x5	.. 3.75	.. 11.00
32x3 1/2	.. 2.25	.. 6.00	36x5 11.50
31x4	.. 2.75	.. 6.50	37x5	.. 4.00	.. 12.00
32x4	.. 2.40	.. 7.50			
33x4	.. 2.70	.. 8.50			
34x4 1/2	.. 2.85	.. 10.00			

Special-Brand New
32x3 1/2, Cord. \$12.25

Order now. Shipment made the same day. \$1 deposit required with each tire order. C. O. D. subject to your examination. Specify whether you desire to have clincher or straight side tire.

Special cash discount of 5 per cent if full amount accompanies order.

CENTRAL TIRE & VULCANIZING CO.,
2309 S. STATE ST., Dept. E. E. CHICAGO

STARTS ANY COLD MOTOR IN A JIFFY

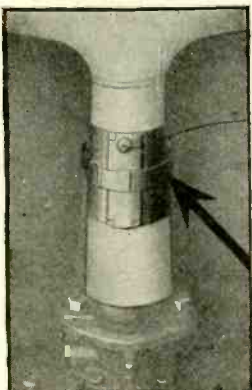

This Electric Intake Heater attaches to intake manifold or carburetor—no drilling, tapping or alterations. Operates from dash switch. Quick starting made sure in coldest weather. For any car with storage battery..... **\$3.50**

Write for descriptive matter

Dealers and Agents get our proposition

Electric Intake Heater Co.
120 Cortland St. Jackson, Mich

TIRES 1/3 LESS

Perfect, new tires, all sizes, non-skid or plain, fabric or cord. Prepaid on approval. 8000 to 10,000 Miles Guaranteed

30,000 Customers. Catalog Free. Agents Wanted. Service Auto Equipment Corporation
995 Service Bldg., Kansas City, Mo.

Popular Astronomy

By Isabel M. Lewis, M. A.

(Continued from page 887)

Let the mirror be fixt at equal distances from A and B in the two systems. A and B will agree that AM equals BM' for the two lengths can be directly compared by assuming A to come into coincidence with B and M with M' as the systems pass. That is, two observers on relatively moving systems will agree in their estimate of the length of a line that lies perpendicular to their line of motion.

Now let A thinking himself at rest note how long it takes for a ray of light to pass from A to M and back in his system. Say he concludes that it takes one second to travel to M and back over the path AMA. Let B thinking himself at rest perform the same experiment in his system. He also will find that it takes one second by his clock for light to travel to M' and back (since the two observers agree on the velocity of light and the equality of AM and BM'). B assumes that the path of the ray of light in his system is BM'B (= to AMA) thinking he is at rest, but A who has been watching B's experiment from S thinks that the path of the ray of light in B's system is BPB' where BB' represents the motion of B relative to A during the interval in which the ray of light is passing to B's mirror and back. A is surprised that B should report that the experiment takes one second, the same time that A found for his experiment, since to A the two paths AMA and BPB' appear unequal in length; so A is forced to conclude that B's time intervals are longer than his own; that is, that B's clock is slower than his clock and B comes to the same conclusion in regard to A's time intervals. That is, the two observers are in hopeless disagreement as to the actual length of the second. From a reference to Fig. 2 we find that the ratio of B's time interval to A's time interval as it appears

of the Kaufman-Bucherer experiments on the mass of electrons shot off from radioactive substances or in cathode rays.

A still more startling conclusion arrived at is that mass itself is a manifestation of a certain form of energy and that "the increase of the kinetic energy of a particle, in ergs, is equal to the increase in mass, in grams, multiplied by the square of the velocity of light," and as a direct result, assuming that matter and energy are different names for the same thing, one gram of matter represents 10²¹ (ten to the twenty-first power) ergs of energy. We must come to the conclusion also that the two laws of the conservation of mass and of the conservation of energy are one and the same thing.

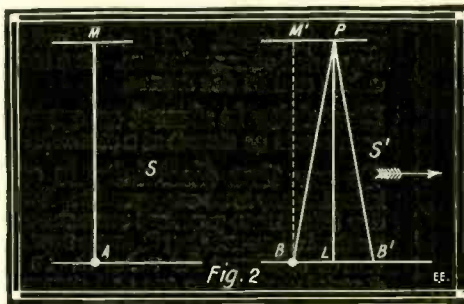

$$(AM)^2 = (BM')^2 = (PL)^2 = (BP)^2 - (BL)^2$$

$$(AM)^2 = 1 - (BL)^2$$

$$\frac{(BP)^2}{(AM)^2} = 1 - \frac{(BL)^2}{(AM)^2}$$

Now BL is to BP as v is to c, Where v is the Velocity of B Relative to A, and c is the Velocity of Light.

Therefore $\frac{AM}{BP} = \sqrt{1 - \frac{v^2}{c^2}}$

and 2 AM is to 2 BP, or AMA is to BPB', as $\sqrt{1 - \frac{v^2}{c^2}}$ is to 1. But A and B Both

Agree that Light Takes One Second to Travel the Two Paths Unequal in Length, Therefore B's Second Must Appear to A to Be Longer Than A's Second in the Ratio

$$\frac{1}{\sqrt{1 - \frac{v^2}{c^2}}}$$

If the motion of the stars thru space is slightly accelerated instead of being uniform, and if increase of mass and energy due to this fact can be changed into energy of radiation, there is then a source of supply of the radiant energy of the sun and stars that can be drawn upon for infinite ages.

It is also possible to deduce from the form of the factor $\sqrt{1 - \frac{v^2}{c^2}}$ that figures

so prominently in the theory of relativity, the fact that no material body can possess a velocity equal to or greater than the velocity of light, for if $V = C$ the expression for the mass of a body moving relative to an observer with the velocity of light because infinite and its length in the line of motion vanishes. Is, then, a ray of light an infinitesimal portion of an infinite mass or energy?

Granted that there can be no velocity equal to or greater than the velocity of light, at what speed, then, does gravitation itself act, which has always been assumed to be instantaneous in its effect?

It can be seen from what we have been able to state, in a more or less detached and incomplete manner, concerning some of the chief deductions to be made from the principle of relativity, that it deprives us of our most cherished ideas concerning the absolute nature of time and space and removes the possibility of the simultaneous happenings of events at different places.

(Continued on page 918)

to A is $1 : \sqrt{1 - \frac{v^2}{c^2}}$ where C is the

velocity of light and V the velocity of B relative to A. That is the amount by which B's clock is slower than A's depends on the relative velocity of A and B.

By similar processes of reasoning we can deduce equally startling conclusions as to the length of a given line in B's system lying parallel to the direction of motion and find that we must come to the conclusion that a moving yard stick (or other unit of length) is shortened parallel to its

line of motion in the ratio of $\sqrt{1 - \frac{v^2}{c^2}} : 1$

as compared with the same rod at rest. That is, the shape of a body relative to a stationary observer is changed in proportion to its velocity relative to the observer, all lines in the body parallel to its direction of motion being contracted in the ratio

$$\sqrt{1 - \frac{v^2}{c^2}} : 1$$

There is, therefore, no absolutely rigid body and the shape of a body depends on its velocity relative to the observer and is different for different systems of reference. A body that appears to us to be circular, say when at rest, will appear spheroidal in shape when moving rapidly and its shorter axis will lie parallel to its direction of motion.

Another startling conclusion to which we are forced by similar processes of reasoning is that the mass of a body at rest is less than its mass when in motion in the

ratio $\sqrt{1 - \frac{v^2}{c^2}} : 1$ depending on its velocity relative to the observer.

This conclusion of relativity has received striking confirmation in the results



Be a Draftsman

Raise Your Income

Get into this paying profession and have positions opened to you by manufacturers, architects, railroads, contractors—by every kind of a corporation where mechanical design and construction are carried out. Draftsmanship puts you in the class of specialists, raises you above the crowd of job hunters, makes you a man whose services are needed.

You have the same opportunity to get the training that other men had who took the Chicago "Tech" Course in Draftsmanship and are now drawing large salaries and holding important, responsible positions. You also can learn how to earn

\$25 to \$100 a Week

Not enough really skilled draftsmen are available to fill the places open now. All you need is training to be prepared to answer the call that will mean more money for you. Begin your training without delay. Don't waste time waiting. The Chicago "Tech" experts are ready today to give you the thorough, practical instruction which will enable you to step into the drafting room of some big organization prepared to do the kind of work that earns high salaries and leads to advancement. At least write. Mail the coupon below or a letter stating which branch specially interests you.

Drawing Outfit

(No Extra Charge)

Every student of the Chicago "Tech" Home Study Course in Draftsmanship receives this drawing outfit—set of instruments in case, drawing board, T square, triangles, scale, curve, drawing paper, pencils, etc. or a cash credit in case he already has an outfit. These instruments are of the same make and sizes as used by high salaried experts in drafting rooms of factories, shops, railroads, etc. You use them while learning—then take them right into your practical work.



Come to Chicago "Tech" OR TRAIN AT HOME

Chicago "Tech" has its students everywhere. If you can't come to Chicago, take the Home Study course. The same professors who direct the resident courses will teach you by mail. You will have their personal direction, you will learn the most modern methods—all this while holding your present job. We train hundreds of ambitious men—and see them quickly rise to success. You therefore need not be denied this technical education. Sign and mail the coupon.

Get Practical Training from Practical Men

NO TIME PUT IN ON NEEDLESS STUDIES

Enrollment with Chicago "Tech" means getting direct personal instruction from men who for years have planned and directed big architectural and engineering work in leading cities. They have weeded out useless theories and needless studies and will give you the kind of instruction which will enable you to work beside the most experienced men. That is one reason why you can get a complete, thorough technical training here in such a short time. Also the reason why Chicago "Tech" men are in such great demand. They go into work prepared to give the kind of service wanted. This is the training you are offered either at the college or by mail. And this is the time to enroll when there is such a pressing need for highly trained draftsmen. Use your spare hours to fit yourself for a bigger salary—a more important position. Chicago "Tech" offers you the opportunity. WRITE.

EASY PAYMENTS

Low tuition fees and easy terms of payment. Pay as you go along. Get training which will soon repay in extra earnings all the cost of the course. You know the salaries received by skilled technical men today. Get information on the opportunities which are opened wide to you by Chicago "Tech". We will give you all this information about fees, terms, etc., and send testimonials from Chicago "Tech" graduates on how they have profited from our instruction, if you will send the coupon.

FREE TEST LESSON

Other institutions ask you to pay first—and then to find out later how well qualified you are for this profession. We send the free lesson first and place you under no obligation at all. Discover your qualifications before you pay anything. And see for yourself just what Chicago "Tech" offers you in training which will bring a ready market for your services and open opportunities which are closed to the untrained man. The coupon will bring all the facts about the course, the small fee, and the easy terms.

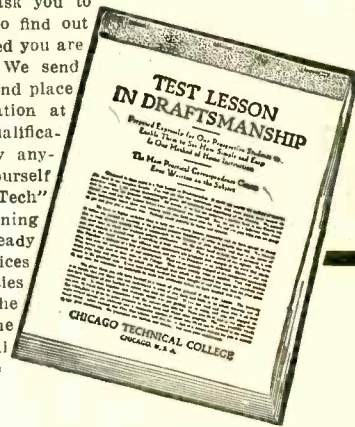

Auto and Gas Engine Course

All about automobile mechanism—its construction, operation and REPAIR—taught by mail. You train directly under the Chicago "Tech" automobile experts. Learn all about Principles of the Automobile, all about Gas Engines, Power Plants, Transmissions, Lubrication, Cooling, Batteries, Starting and Lighting Systems, etc.

KNOW HOW TO FIX TROUBLES

Most complete instruction in auto repair work. Equips you for high pay or to start a business. Big demand for trained repair men.

Aeronautics

Complete, practical instruction in Aeronautic Engineering. Every principle made clear. Construction of every type of machine fully explained. This course equips you for expert work. Get the catalog and information. Send coupon.

WRITE

Below we list our principal courses in Drafting and several others. Just mark X in the [] to show which course interests you and we will send catalog and information about that particular subject. If in doubt about yourself, tell us your ambitions and we will advise you. Sending this coupon may mark a turning point in your career. May lead to a larger measure of success than you have expected. We can train you as we have trained others. Send the coupon today.

CHICAGO TECHNICAL COLLEGE

145 Chicago "Tech" Building, Chicago

Without obligation upon me, send your Catalog on subject indicated below. Also FREE Lesson if Inquiry is on Drafting or Plan Reading.

Mark X opposite work in which you are especially interested.

- | | |
|---|---|
| <input type="checkbox"/> Architectural Drafting | <input type="checkbox"/> Plan-Reading—Buildings |
| <input type="checkbox"/> Machine Drafting | <input type="checkbox"/> Plan-Reading—Shop Men |
| <input type="checkbox"/> Electrical Drafting | <input type="checkbox"/> Estimating |
| <input type="checkbox"/> Structural Drafting | <input type="checkbox"/> Surveying |
| <input type="checkbox"/> Sheet Metal Drafting | <input type="checkbox"/> Autos and Gas Engines |
| <input type="checkbox"/> Builders' Course | <input type="checkbox"/> Aeronautics |

Name.....

Address.....

City..... State.....

College or Home Study? State which.....

CHICAGO TECHNICAL COLLEGE
145 Chicago "Tech" Building, Chicago

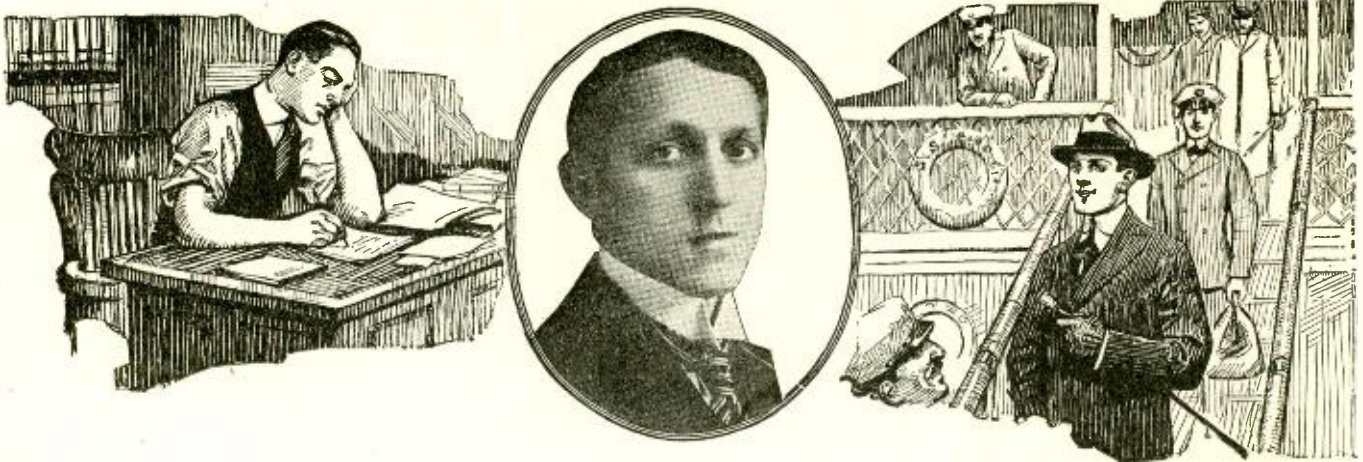

A New Idea that Makes Men Rich

SEVEN men tried out this idea. Each was earning less than \$40.00 a week in a routine position. To-day five of these men draw salaries ranging from \$8,000 to \$40,000 a year, the sixth is wealthy, and the seventh is worth a half-million dollars. How they did it and how you, too, can duplicate their amazing success.

YOU men and women who are eager for success—I wish you could have been with me one memorable evening last week. For then I had spread before me seven of the most remarkable cases of success of which I've ever heard.

It all came about in this way. At a convention in New York I met two old friends who had at one time worked for the same firm. Each of these men had since won remarkable success. As we sat in my room at the hotel, my two friends—Perry and Gordon—got to talking about old times and the men they used to work with. The talk turned to what their former associates were doing now. "Let's see," said Gordon, "there's Bill Baley—now he's vice-president of a bank at \$10,000 a year. Lawrence is general manager of a machinery house at \$18,000 a year. Yawman is foreign Sales Manager for an automobile concern and makes \$40,000 a year. Stanton is manager of the New York branch and last year made in salary and commission over \$28,000. Burton is in the wholesale business for himself and tells me that in the past three years he has cleaned up a fortune. Even old Harry Carter, whom everybody thought a dud, is Secretary of a concern down South and knocks out \$8,000 a year. And Zimmerman, our old boss, is director of more concerns than I can think of and is rolling in money."

"**F**UNNY thing," said Perry, "every man who worked in that department under Zim has made a conspicuous success. In the ordinary course of events you'd naturally expect one or two of the men to win out while the others would plug along and never amount to anything unusual. But every one of these men has since made a name for himself. I wonder if it just happened or if there is a reason."

"I used to think about that a lot myself," cut in Gordon, "and I believe I've found the answer. It's Zim, our old chief. That's who we've all got to thank for our success."

"Remember what a slave driver we used to think him. When he wanted a thing done it had to be done, done quickly and done right. He'd tell us some of the most impossible things, and he made us do them. Excuses didn't go. We nicknamed him 'Old Must.' Must do this—must do that. No excuses. Simply must do it. We knew it couldn't be done. Yet we got it done—always!"

"We couldn't kick because he drove himself as much as he drove us. Remember the line of talk

he used to hand us day in and day out. 'It must be done. You can do it. Get a grip on yourselves, boys. Throw your Will into action. Drive! Will-power will carry you through.'

"I never took much stock in that Will talk those days. I thought it was just one of Zim's pet theories. But now I see that Zim was right—wonderfully right."

"The reason why our department always broke records, and why every man in that department has since made a big success is because Zim put the drive into us—he taught us how to use our Will-power. That's what put us all where we are—the winning drive that comes from Will-power."

WHEN you come right down to it the only real difference between men is not birth nor education nor luck, but Will-power. The successful man is successful because he knows how to use his Will. He compels success.

The unsuccessful man is unsuccessful because he does not know how to use his Will and is forced to meekly bow down to circumstances. Not one man in a hundred knows how to use his Will. That is why more men are not successes. Nearly every successful man has a highly developed Will—the stronger the Will the greater the success. Natural ability amounts to but little unless backed by a dominant, compelling, driving Will.

The Will is the motive power of the brain. Without a highly-trained, inflexible Will, a man has about as much chance of attaining success in life as a locomotive has of crossing the continent without steam. The biggest ideas have no value without Will-power to "put them over." Yet the will, although heretofore entirely neglected, can be trained into wonderful power like the brain or memory. And by the very same method—intelligent exercise and use.

If you held your arm in a sling for two years it would become powerless to lift a feather, from lack of use. The same is true of the Will—it becomes weak from lack of use. Because we do not use our Wills properly—because we continually bow down to circumstances—we become unable to assert ourselves. What our Wills need is practice.

Develop your Will-power and money will flow in on you. Rich opportunities will open up for you. Driving energy you never dreamed you had will manifest itself. You will thrill with a new power—a power that nothing can resist. You'll have an influence

over people that you never thought possible. Success—in whatever form you want it—will come as easily as failure came before. And those are only a few of the things Will-power will do for you. Just how to develop the Will into a mighty, irresistible force—how to make it do all these things for you—is fully explained in that wonderful book "Power of Will."

SOME of the things "Power of Will" has done for people are astounding. I would hardly believe them if I hadn't seen them with my own eyes. Adding ten, twenty, thirty or forty dollars a week

to a man's income is a mere nothing. That's merely playing at it. In one case I took a rank failure and in a few weeks had him earning as high as \$2,000 a week. Listen to this:

A young man in the East had an article for which there was a nation-wide demand. For twelve years he "puttered around" with it—barely eking out a living. Then he read "Power of Will." Today this young man is worth \$200,000. He is building a \$25,000 home—and paying cash for it. He has three automobiles. His children go to private schools. He goes hunting, fishing, traveling, whenever the mood strikes him. His income is over a thousand dollars a week.

In a little town in New York lives a man who two years ago was pitied by all who knew him. From the time he was fourteen he had worked and slaved—and at sixty he was looked upon as a failure. Without work, in debt to his charitable friends, with an invalid son to support, the outlook was pitchy black. About this time he ran across a copy of "Power of Will."

In two weeks he was in business for himself. In three years his plant was working night and day to fill orders. During 1916 the profits were \$20,000. During 1917 the profits ran close to \$40,000. And this genial 64-year-old man is enjoying pleasures and comforts he little dreamed would ever be his.

AMAZING things like these "Power of Will" has done for men and women in all walks of life. There is no sound reason why it will not bring about the same surprising results for you. You at least owe it to yourself to find out. And I'm willing to prove it to you wholly at my expense. You can easily make thousands—you can't lose a cent. Here is my offer:

Send no money—no, not a cent. Merely clip the coupon and mail it to me. By return mail you'll receive not a pamphlet, but the whole "secret" told in this wonderful book, "Power of Will."

Keep it five days. Look it over in your home. Apply some of its simple teachings. If it doesn't show you how you can increase your income many times over—just as it has for thousands of others—mail the book back. You will be out nothing. But if you feel that "Power of Will" will do for you what it has done for over a quarter of a million others—if you feel as they do that it's the next greatest book to the Bible—send me only three and a half dollars and you and I'll be square.

If you pass this offer by, I'll be out only the small profit on a three and a half-dollar sale. But you—you may easily be out the difference between what you're now making and an income several times as great. So you see you've a lot—a whole lot—more to lose than I. Mail the coupon or write a letter now—you may never read this offer again.

PELTON PUBLISHING CO.

30-A Wilcox Block Meriden, Conn.

PELTON PUBLISHING COMPANY,
30-A Wilcox Block, Meriden, Conn.

You may send me "Power of Will" at your risk. I agree to remit \$3.50 or remail the book to you in five days.

Name
Address
City..... State.....

A Few Examples

Personal Experiences

Among over 350,000 users of "Power of Will" are such men as Judge Ben B. Lindsay, Supreme Court Justice; Parker, Wu Ting Fang, ex U. S. Chinese Ambassador; Assistant Postmaster Britt; Gov. McKelvie of Nebraska; General Manager Christenson of Wells-Fargo Express Co.; E. St. Elmo Lewis, former Vice Pres. Art Metal Construction Co.; Gov. Ferris of Michigan, and many others of equal prominence.

\$300 Profit From One Day's Reading

"The result from one day's study netted me \$300 cash. I think it a great book and would not be without it for ten times the cost."—A. W. Wilke, Faulkton, So. Dakota.

Worth \$15,000 and More

"The book has been worth more than \$15,000 to me."—Oscar B. Sheppard, 1417 E. Locust St., Decatur, Ill.

Would Be Worth \$100,000

"If I only had it when I was 20 years old, I would be worth \$100,000 today. It is worth a hundred times the price."—S. W. Taylor, The Santa Fe Ry., Millans, Tex.

Salary Jumps from \$150 to \$800

"Since I read 'Power of Will' my salary has jumped from \$150 to \$800 a month."—J. F. Gibson, San Diego, Cal.

From \$100 to \$3,000 a Month

"One of our boys who read 'Power of Will' before he came over here jumped from \$100 a month to \$3,000 the first month, and won a \$250 prize for the best salesmanship in the state."—Private Leslie A. Still, A. E. F., France.

BATTERY CHARGING PAYS BIG PROFITS

HB Users Make \$100 to \$350 Clear Profit Every Month
 NOW is the time to make BIG profits in battery charging. Cars are stored for winter with batteries to keep in condition. Who gets this big, money-making business? You or your competitor who is farsighted enough to install a sturdy, reliable HB Battery Charger? Is it good business for you to pass by the opportunity to add \$100 to \$350 EXTRA PROFIT to your income every month? Start NOW to get those big battery charging profits. It costs only 10c to 15c each to charge batteries—customer pays 75c to \$1.50. HB Chargers are sturdy, dependable and absolutely reliable. No expensive renewals or repairs. Big, quick, clean profits, easily made.

CHOOSE THE SIZE YOU NEED

HB 500-Watt Charger
 Recharges 1 to 8 6-volt batteries or their equivalent at a time. Furnished complete with clear, black electrical, slate switch-board, with mountings of ammeter, field rheostat, voltage lamp, two controlling switches. A big money-maker for a small battery business.

\$15.00 Cash; Balance on Easy Monthly Terms

HB 16-Battery Charger
 Recharges 1 to 16 6-volt batteries at once or their equivalent in 12 or 24-volt batteries. Furnished complete with 2 independent charging panels, each with a capacity of 8 batteries. A splendid machine for a live, energetic garage owner wishing to get big profits.

Small Cash Payment, Balance on Easy Monthly Terms

HB 32-Battery Charger
 Recharges 1 to 32 6-volt batteries or equivalent at a time. Four separate charging lines, each capable of charging up to 8 batteries. Ideal equipment for big garage or battery service station. Will make as high as \$250 to \$450 a month clear profit.

Small Cash Payment, Balance on Easy Monthly Terms

Sold on Trial Under HB Absolute Money-Back Guarantee
 All HB Equipment is sold under our absolute guarantee of complete satisfaction. You run no risks. If not satisfied after using any HB Equipment 10 days, you may return it and receive all you paid us. The HB monthly payment plan is an additional guarantee.

Select the Charger You Need. Check the Coupon Below.
 Mark on this coupon the HB Charger you are interested in. Tear it out and mail TODAY. Be the first in your town to have an HB Charger. Don't delay. Act now.

-----TEAR OFF HERE-----

HOBART BROS. CO., Box 17E TROY, OHIO
 Send me information about the HB equipment checked below, and tell me about the HB Money-Back Guarantee and Trial plan:

- ..HB 8-Battery Charger ..HB Belted Charger
- ..HB 16-Battery Charger ..(Used where electric current is not available.)
- ..HB 32-Battery Charger

Your Name
 AddressState

Magnetic Storms

By Prof. Lindley Pyle

(Continued from page 876)

displays. At such times conditions on the sun are no doubt such as to affect either directly or indirectly the magnetic field of

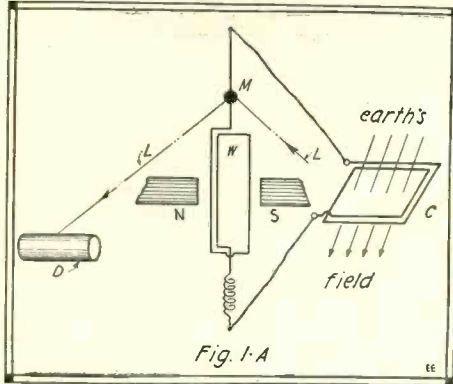

Apparatus Used in Recording "Magnetic Storms." Suspended Coil of Wire, W; Mirror, M, Attached to W.

the earth. Direct evidence of this was obtained August 3, 1872, when Young, at Sherman, Idaho, observed a solar outburst during an eclipse of the sun. At the same instant magnetic observatories in England recorded magnetic disturbances. On the other hand Professor Francis E. Nipher, the American investigator and scientist, has noted "magnetic effects" arising from purely local weather conditions.

To obtain an automatic registration of the irregular and continuous changes occurring in the earth's magnetic field, the writer assembled the the apparatus photographed and diagrammed in Figs. 1 and 1-A. A simple coil of wire C, is laid upon a table and its terminals are connected to a sensitive electric indicator, or galvanometer. See Fig. 1-A. That part of the galvanometer

that moves when a current traverses the galvanometer is equipt with a small mirror. Within the black box is a strong source of light placed behind a pin-hole. Light passing thru the pin-hole traverses the lens shown in the photograph, falls upon the galvanometer mirror and is reflected to a revolving cylinder D, driven by clock-work and covered with photographic bromide paper. One has in fact upon the paper the bright image of the illuminated pin-hole. In practise the cylinder with its light-sensitive paper is protected from any stray light by a cover equipt with a narrow slit thru which the light enters to fall upon the moving paper. Subsequent chemical development of the paper yields a permanent record of the behavior of the beam of light, which wags to and fro in accordance with the behavior of the galvanometer mirror. In accordance with Faraday's laws of induced currents there is an electromotive force induced in the coil which is proportional at any instant to the rate of change of the number of lines of the earth's magnetic field linking with the

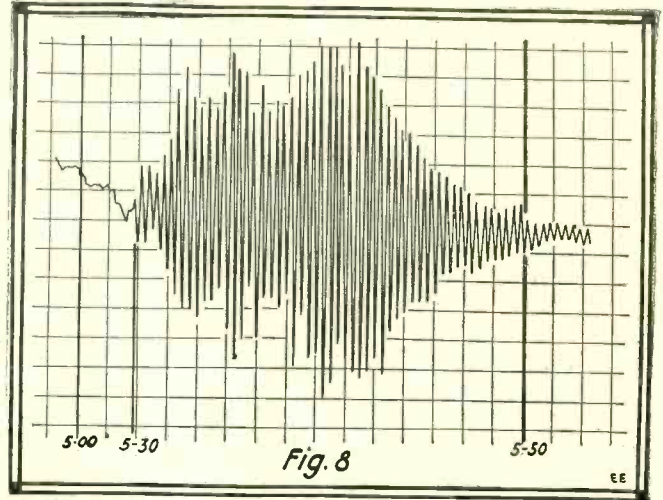

A Wonderful Record of a Magnetic Storm Due to the "Sun-Set" Effect.

coil. Consequently every change in the earth's magnetic field is accompanied by a current flow thru the galvanometer and a motion of the spot of light on the moving paper. No doubt the fluctuations recorded in Fig. 2 are in large part due to effects of electric car lines about 700 feet distant from the apparatus. In certain work by the U. S. Government car effects have been noted at a distance of 13 miles from the car lines. This method of registration of magnetic storms is not new. It was first put into practise in a certain Polar

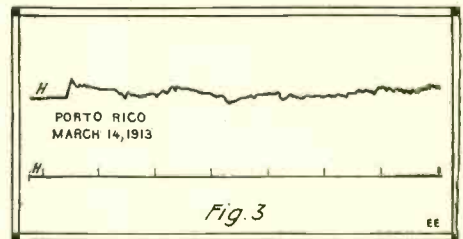

Portion of Automatic Record of a "Magnetic Storm" of 98 Hours' Duration, Taken at Vieques, Porto-Rico.

Expedition of 1882-83, when a single insulated wire was laid out upon the polar ice to enclose an area of approximately three square miles. The Einthoven type of galvanometer is the best type to use in con-

(Continued on page 922)

Be a Doctor of Chiropractic

The greatest professional opportunity today, for the following reasons:

- 1.—The demand for practitioners is greater than the supply.
- 2.—The profession is not overcrowded nor will it be for years to come.
- 3.—Greater financial returns because of greater service to the public.
- 4.—It is attracting the support of the most intelligent people because it is based upon scientific knowledge of the human body both in health and in disease.
- 5.—Because we invite investigation for every statement we make and extend the privilege of a personal visit to our classes to permit you to form your own opinion as to the training you receive here.

Midwinter enrollment. Special inducements for enrollment in this class. Write or call for particulars at once, as this opportunity will not last long

New York College of Chiropractic

Dr. M. CARNOT, President

WRITE FOR BOOKLET X

1416 Broadway, cor. 39th St., N. Y. C.

Bryant 6956-6957

New Method Makes Music Amazingly Easy to Learn

Learn to Play or Sing in Spare Time at Home. Every Step Made Simple as A B C by Print-and-Picture Lessons That You Can't Go Wrong On.

TRY IT ON APPROVAL.

Entire Cost Only a Few Cents a Lesson — and Nothing Whatever to Pay Unless You Are Satisfied.

How often have you wished that you knew how to play the violin or piano—or whatever your favorite instrument may be—or that you could take part in singing?

How many an evening's pleasure has been utterly spoiled and ruined by the admission "I can't sing," or "No, I am sorry, but I can't play."

At all social gatherings, some one is sooner or later sure to suggest music. When the others gather around for the fun, the one who can take no part feels hopelessly out of it—a wall flower—a mere listener and looker on!

Or those long and lonesome evenings at home, when minutes seem like hours—how quickly the time would pass if you could spend it at the piano or organ—or in making a violin "talk," or in enjoying some other instrument.

And now—at last—this pleasure and satisfaction that you have so often wished for can easily be added to your daily life.

No need to join a class or pin yourself down to certain hours for lessons or practice. No need to pay a dollar or more per lesson to a private teacher. Neither the question of time nor expense is any longer a bar—every one of the obstacles that have been confining your enjoyment to mere listening have now been removed.

My method of teaching music by mail—in your spare time at home, with no strangers around to embarrass you—makes it amazingly easy to learn to sing by note or to play any instrument.

You don't need to know the first thing about music to begin—don't need to know one note from another. My method takes out all the hard part—overcomes all the difficulties—makes your progress easy, rapid and sure.

Whether for an advanced pupil or a beginner, my method is a revolutionary improvement over the old methods used by private teachers. The lessons I send you explain every point and show every step in simple Print-and-Picture form that you can't go wrong on—every step is made as clear as A B C. My method makes each step so easy to understand and practice that even children only 7 to 10 years old have quickly become accomplished players or singers under my direction by mail. Also thousands of men and women 50 to 70 years old—including many who had never before tried to play any instrument or taken a lesson of any kind—have found my method equally easy. My method is as thorough as it is easy. I teach you the only right way—teach you to play or sing **by note.**



No "trick" music, no "numbers," no makeshifts of any kind.

I call my method "new"—simply because it is so radically different from the old and hard-to-understand ways of teaching music. But my method is thoroughly time-tried and proven. Over 225,000 successful pupils—in all parts of the world, and including all ages from boys and

girls of 7 to 8 to men and women of 70—are the proof. Read the enthusiastic letters from some of them, which you will find printed at the right—samples of the kind of letters I am receiving in practically every mail. My file contains thousands of such letters. Largely through the recommendations of satisfied pupils, I have built up the largest school of music in the world.

But I don't ask you to judge my methods by what others say or by what I myself say. You can take any course on trial—singing or any instrument you prefer—and judge entirely by your own progress. If for any reason you are not satisfied with the course or with what you learn from it, then it won't cost you a single penny. I guarantee satisfaction. On the other hand, if you are pleased

with the course, the total cost amounts to only a few cents a lesson, with your music and everything also included.

When learning to play or sing is so easy, why continue to confine your enjoyment of music to mere listening?

Why not at least let me send you my free book that tells you all about my methods? I know you will find this book absorbingly interesting, simply because it shows you how easy it is to turn your wish to play or sing into an actual fact. Just now I am making a special short-time offer that cuts the cost per lesson in two—send your name now, before this special offer is withdrawn. No obligation—

simply use the coupon or send your name and address in a letter or on a postcard. Instruments supplied when needed, cash or credit.

U. S. School of Music

1331 Brunswick Bldg.

New York

SUCCESS

"Since I've been taking your lessons I've made over \$60 with my violin. Your lessons surely are fine." — Melvin Freeland, Macopin, N. J.

"When I started with you I knew nothing about the Cornet or music, but now I can play almost any piece of music." — Kasson Swan, Denmark, Col. Co., Nova Scotia.

"I want to extend the heartiest approval of your Piano Course. It has done more for me than years of other lessons." — Moxie N. Lewis, 319 Jefferson, Neosha, Mo.

"The folks at home are delighted to hear me play the Organ so well. You have a wonderful system of teaching music." — M. F. Allard, Caracas, N. B.

Learn to Play by Note For Beginners or Advanced Pupils

- | | |
|-------------|---------------|
| Piano | Harmony and |
| Organ | Composition |
| Violin | Sight Singing |
| Viola | Guitar |
| Banjo | Ukelele |
| Tenor Banjo | Hawaiian |
| Mandolin | Steel Guitar |
| Clarinet | Harp |
| Flute | Cornet |
| Saxophone | Piccolo |
| Cello | Trombone |



Mr. David F. Kemp, President

U. S. School of Music, 1331 Brunswick Bldg., New York City.

Please send me your free book, "Music Lessons in Your Own Home," and particulars of your Special Offer.

Name.....

Address.....

City.....State.....

Make \$2,500 to \$4,000 a Year in

HAYWOOD'S TIRE SURGERY

5,000 More Miles To Old Tires

Stations Needed Everywhere

You know that 4,000 to 5,000 additional tire mileage means to motorists. Haywood's Tire Surgery is a new tire repair method that gives new life and thousands of miles of additional service to tires which before would be thrown in the junk pile. Think of what this means, man, as a money making opportunity. Think of the business that is going begging to pay you big money if you're ready to act.

HAYWOOD'S TIRE SURGERY Is a Wonderful Business

Easy to Learn—No Experience Necessary

Uncountable millions of tires are cut, torn, gashed and bruised, broken down, worn out, yet with the Haywood method of tire surgery all these tires, no matter how far gone, can be put back into service. Every town, every hamlet, every city needs Haywood Tire Surgeons, and it's that we are offering you—a business of your own—a business that is already making hundreds of men rich and so will make you.

YOU CAN LEARN IN A WEEK. Walk right into \$2500 to \$4000 a year—be independent in business for yourself. Let us send you all the facts.

Mail Coupon—Get My Free Book

Just put your name and address on the coupon below, send it to me by return mail, and I'll send you without obligation full particulars of this money making opportunity. My Free Book explains everything. Tells how to start business with very little money. Now you can easily and quickly learn all about tires and my method of Tire Surgery. It will tell you how to handle every detail of the business. In fact, how to succeed and make money. Don't wait. Write me today. The postage for a stamp or post card will prove the best investment you ever made.

M. HAYWOOD
Founder of
Tire Surgery

M. HAYWOOD, President

HAYWOOD TIRE & EQUIPMENT COMPANY
1209 CAPITAL AVENUE INDIANAPOLIS, INDIANA

Mail To-day For All Facts

M. HAYWOOD D, President
HAYWOOD TIRE & EQUIPMENT COMPANY
1209 Capitol Avenue, Indianapolis, Indiana

Dear Sir—Send me quick, without obligation, full particulars of Tire Surgery.

Name _____

Address _____

Earns \$800 Month

This is **E. T. Buchmann**



He is a Tire Surgeon at Chicago. He says: "Am earning \$800.00 per month, and confining myself solely to re-building of Tires by Haywood Method."

\$6,500.00 Home Paid For

John W. Blair, Toledo, Ohio, says: "When I started three years ago, I had just \$50.00 left after paying for my outfit. I now have a \$6,500.00 home paid for, \$1,000.00 in one bank, and deposits in several others."

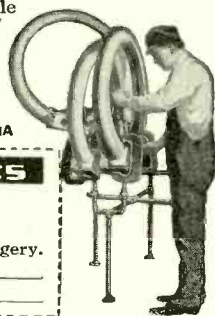

OPEN A TIRE REPAIRING SHOP!!
BUSINESS GOOD AND FAST GROWING

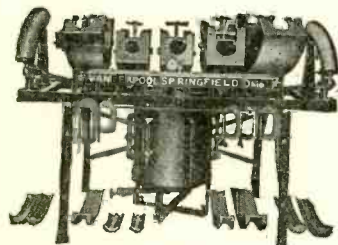

VANDERPOOL VULCANIZER (5 Cavity), has capacity of \$100 worth of work a day. We are the pioneers in the manufacture of the Dry Cure Vulcanizer.

With the **VANDERPOOL VULCANIZER** no experience is necessary. We give you free instructions. Write today for **FREE TIRE REPAIRING MANUAL** and full particulars. If others can be successful, so can you be. Write today.

In answering address Dept. R. 20

WM. VANDERPOOL CO., - - Springfield, O.

"The Eastern" is a Large Achromatic Telescope

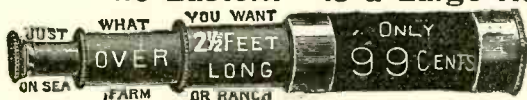

MADE UPON NEW SCIENTIFIC PRINCIPLES.

Positively such a good Telescope was never sold for this price before. Eastern Telescopes are made by one of the largest manufacturers of telescopes in America; we control entire production; measure closed 9 inches and open over 3 feet in 4 sections. They are nicely brass bound, with scientifically ground lenses. Guaranteed by the maker. Every sojourner in the country or at the seaside resorts should certainly secure one of these instruments, and no farmer should be without one. The scenery just now is beautiful. A Telescope will aid you in taking views. Objects are brought to view with astonishing clearness. Sent by mail or express, safely packed, prepaid, for only 99 cents. Our new Catalogue of Watches, etc., sent with each order. This is a grand offer and you should not miss it. We warrant each telescope just as represented or money refunded. Send 99 cents by Registered Letter, Post Office Money Order, Express Money Order, or Bank Draft payable to our order, or your newsdealer or store-keeper will order one for you. Whether consumer or dealer, send cash with order. To dealers 6 for Four Dollars.

EASTERN NOVELTY CO., 67: 172 E. 93d STREET, NEW YORK.

Magnetic Storms

(Continued from page 920)

nection with the test coil, since the moving part consists of but a single, very thin conducting filament stretched across the gap of a powerful magnet. The filament being

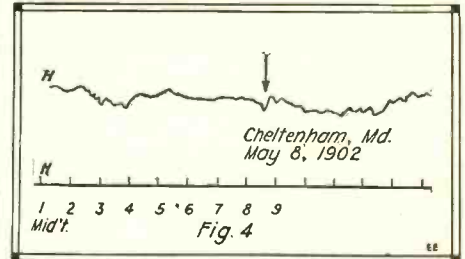

Record Taken in Maryland of Magnetic Disturbance that Accompanied the Eruption of Mt. Pelée, Martinique, in 1902.

so light follows accurately even extraordinarily rapid variations in the earth's field.

Fig. 3 is a portion of an automatic record of a "Magnetic Storm" of 98 hours' duration taken at the Magnetic Observatory at Vieques, Porto Rico, March 14, 1913. This record differs from that of Fig. 2 in that it is a record obtained from a mirror attached directly to a suspended magnetic needle arranged to move under the varying pull of the earth's field. Also it differs in the rate of motion of the recording paper, being only about one-thousandth the rate used in the case of Fig. 2.

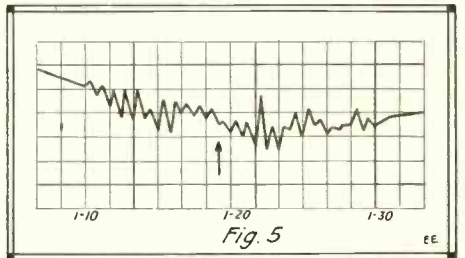

Record Taken by Prof. Nipher of a Magnetic Disturbance Arising from a Violent Squall of Wind.

VOLCANIC ERUPTION CAUSED MAGNETIC DISTURBANCE

Fig. 4 is a careful copy of an automatic record taken at the U. S. Magnetic Observatory at Cheltenham, Md., May 8, 1902. It records the magnetic disturbance that accompanied the eruption of Mt. Pelée, Martinique (see arrow). This magnetic disturbance was recorded simultaneously at Cheltenham and at Baldwin, Kansas, and occurred as nearly as could be determined simultaneously with the eruption. This disturbance was purely a magnetic one and not a mechanical one due to any transmitted earthquake shock.

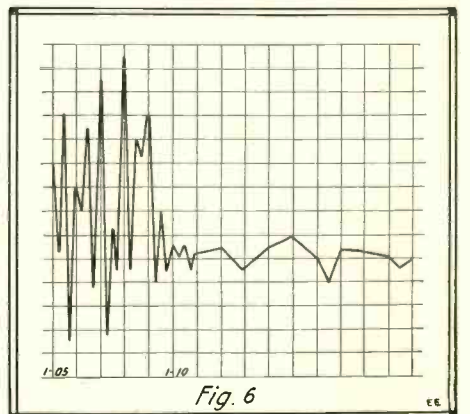

Magnetic Disturbance Produced by Sunlight Shining Thru Rainfall; After a Record by Prof. Nipher.

The greater part of our magnetic storms come from causes outside the earth's crust. Recent researches by Professor Nipher have extended markedly our knowledge of the origin of disturbances impressed upon the

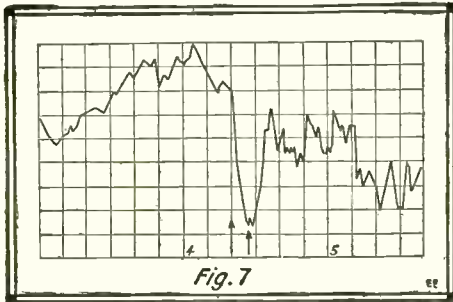

Illustrating the Effect Upon the Strength of the Earth's Magnetic Field of a Large, Dense and Sharply Defined Cloud Passing over the Sun.

earth's magnetic field. In a series of important papers published by the Academy of Science of St. Louis, Professor Nipher has shown conclusively that magnetic storms may arise from wind effects, rain storms, and cloud shadows. He has produced magnetic effects from flames and explosions and has observed magnetic effects due to sounds.

A WIND SQUALL CAUSES "MAGNETIC STORM"

Fig. 5 is one of Prof. Nipher's records of a magnetic disturbance arising from a violent squall of wind. The beginning of disturbances was noted nine minutes before the wind squall reached the observing sta-

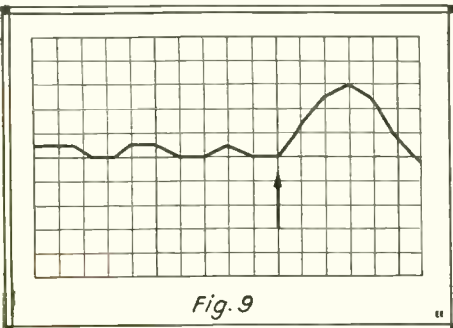

Record Produced by a Flame Creating a Magnetic Disturbance Close to the Recording Station.

tion (time of arrival indicated by the arrow) and the disturbances continued for eight minutes after the squall had past the station. Quoting from one of the original papers,—“When small clouds are scattered over the sky and a local fall of rain occurs at the observing station, the sunlight passing thru the air, thru which the rain drops fall, a very marked magnetic storm is produced.” Such a disturbance is reproduced in Fig. 6. Fig. 7 represents the effect upon the strength of the earth's magnetic field of a large, dense, and sharply defined cloud passing over the sun. The sun disappeared at 4:20 and reappeared at 4:28,—indicated

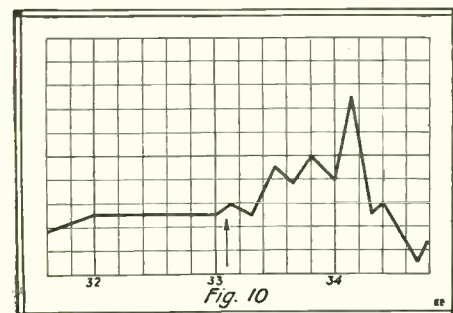

The Magnetic Effect of an Explosion of 21 Sticks of Dynamite, 200 Feet North of the Observing Station.

Learn Mechanical Drafting

Earn \$35 to \$100 a Week

“Get into the profession of big pay and Rapid Advancement with the help of the school that has started hundreds on the Road to Success. I am ready to help you.” Roy C. Clafin, President, Columbia School of Drafting.

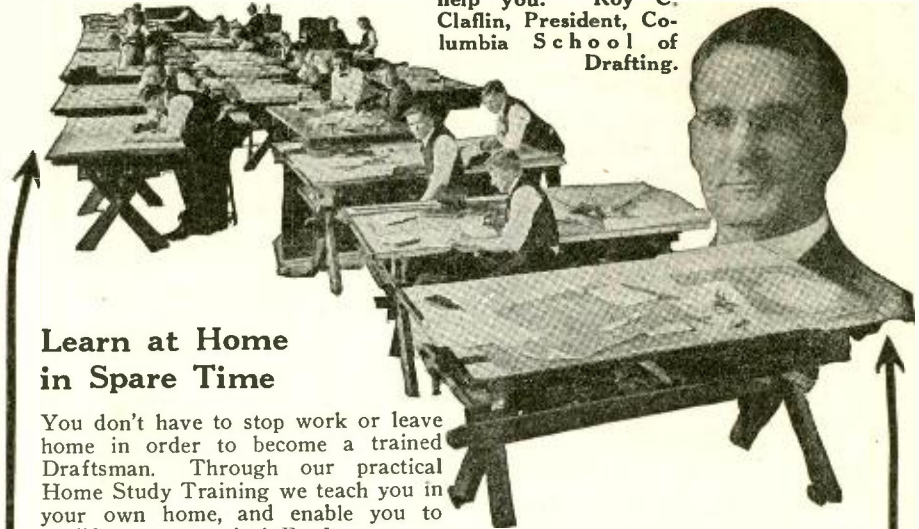

Learn at Home in Spare Time

You don't have to stop work or leave home in order to become a trained Draftsman. Through our practical Home Study Training we teach you in your own home, and enable you to qualify as a practical Draftsman.

No Previous Training Required

Owing to the comprehensive nature of our course, you need no previous training in the subject. Though you have never done any kind of drawing before, you can become a thorough Draftsman by following our instructions.

Can Learn in Short Time by Our Methods

The reason for this is that we eliminate unnecessary theoretical work and concentrate upon the PRACTICAL problems such as confront the professional Draftsman. We do not require you to spend months of your time on “preliminary” work, but start you on REAL DRAFTING at once. That is one reason why our students “make good” so readily.

Our Graduates Get to the Top

The universal success of our graduates as Professional Draftsmen, many of whom have advanced rapidly to positions of Chief Draftsmen, is evidence of the REAL VALUE of the training given by the COLUMBIA SCHOOL OF DRAFTING. Large numbers of our students have secured excellent positions even before completing their courses. We gladly cooperate with our students and graduates in securing desirable positions, which has been easy for us owing to the many demands upon us to supply our “product” for these positions.

Draftsmen Get \$35 to \$100 a Week

Our graduates have shown their ability to reach high salaries RAPIDLY, owing to their practical training. They secure excellent salaries AT THE START, as high as \$2,000 a year. The usual pay of Draftsmen is \$35 to \$100 a week.

The Demand is Greater Than the Supply

The demand for properly trained Draftsmen has always been greater than the supply, but this is more so today than ever before, owing to greatly increased construction and mechanical development. The Draftsman is an essential connecting link in all engineering work. This great demand is indicated by the long lists of want ads for Draftsmen in the daily papers, especially those of industrial centers.

Specialists in Mechanical Drafting

The COLUMBIA SCHOOL OF DRAFTING not only trains Draftsmen by mail but also maintains a large local institution of the highest standing. For many years it has been the leader in SPECIALIZING on the teaching of DRAFTING. This is an obvious advantage over teaching Drafting only as a side issue.

Drawing Outfit Furnished

We supply all our students with a drafting outfit for use throughout the course. There is no extra charge for this, and it becomes your personal property when the course has been paid for in full.

Book of Particulars Sent FREE

If you are interested in becoming a practical Draftsman through the thorough training of the COLUMBIA SCHOOL OF DRAFTING, whereby you can enter a Profession in which your services will always be in demand, you are invited to write us for our free book of particulars, which describes our school and methods. For your convenience you can fill out and

Mail This Coupon To-day

COLUMBIA SCHOOL OF DRAFTING,
14th & T Sts., N.W., Dept. 1075,
Washington, D. C.

Without obligation to me, please send me full particulars of your practical home study training in Drafting.

Name

Address

City..... State.....



Where Upkeep Counts Most

Twelve million miles of wire, connecting cities, villages, farms; running under busy streets and across trackless prairies; these are the Bell Telephone's avenues of speech.

These twelve million miles of wire, throughout every foot of their length, must be kept electrically capable.

A few drops of water within a cable may cut off a thousand subscribers. A line snapped by storm may isolate a district. A wet leaf touching a wire may stop service. In most kinds of

work the lessening of efficiency means merely the lessening of service; but with the telephone, mechanical and electrical conditions must be practically perfect to insure operation.

The most delicate electrical currents in use are those of the telephone, and inspection must be ceaseless that the lines may be kept in constant readiness.

These conditions and costs must be met to provide this high standard of service needed and demanded by the American people.



AMERICAN TELEPHONE AND TELEGRAPH COMPANY
AND ASSOCIATED COMPANIES

One Policy One System Universal Service

BATTERY CHARGED AT HOME

COLD WEATHER WON'T BOTHER YOUR STARTER
and your battery will last years longer if kept fully charged with the

F-F BATTERY BOOSTER

The new size 6 Ampere \$15.00 F-F Bantam Battery Booster charges a 6 Volt battery efficiently from 110 Volt 60 Cycle A. C. current. Attaches to any lamp socket and costs no more for current than burning a lamp. Battery is left right in car without disconnecting and charged over night unattended. New 5 Ampere 12 Volt Bantam at \$20.00.

Send check for express shipment. For parcel post add postage and insurance to cover shipping weight of 15 pounds. Ask for bulletin 12 describing this and other F-F charging apparatus of larger capacities including those operating on farm lighting plants, etc.

Write for Bulletin No. 12

THE FRANCE MANUFACTURING CO., Cleveland, Ohio



**\$15
AND UP**

by the arrows. Eclipse shadows produce similar results. Fig. 8 shows the magnetic storm due to the "sun-set" effect. It thus appears that the earth's shadow at night has the same effect upon the earth's magnetic field that a cloud shadow has during the day. Fig. 9 is a record of the magnetic effect of a flame produced close to the observing station by the burning of 25 or 30 pounds of black powder, spread uniformly over a platform of 20 square feet area. There is in this case no explosive effect. Fig. 10 records the Magnetic effect of an explosion of 21 sticks of dynamite 200 feet north of the observing station. Fig. 11 represents the magnetic effect of disturbances set up by sound waves, emitted by a fog-horn several thousand feet distant from the station.

Professor Nipher states that his researches have established beyond any question that local variations in the earth's magnetic field are determined wholly by local weather conditions. He concludes that the great majority of magnetic disturbances may be traced to variations in the magnetic permeability of the atmosphere, arising from changing conditions in the ionized air.

That the subject of Terrestrial Magnetism is of paramount practical and theoretical interest and importance is evidenced by the large number of magnetic observatories maintained by the leading governments of the world, and by the immense amount of work being carried on in the conduction of magnetic surveys on land and sea. Our own Department of Commerce, thru the United States Coast and Geodetic Survey, continually publishes a large amount of material. An extensive bibliography of the

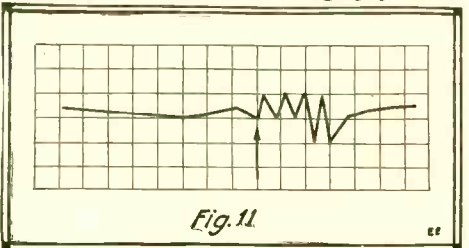

Fig. 11
Magnetic Disturbance Set Up by Sound Waves Emitted by a Fog-horn Several Thousand Feet Distant from the Observing Station.

subject may be found in an international quarterly journal published under the name "Terrestrial Magnetism and Atmospheric Electricity," by the Department of Terrestrial Magnetism of the Carnegie Institution of Washington, D. C.

WHAT ONE RESEARCH LABORATORY DID.

In the research laboratories of a large American electrical manufacturing concern are many scientists working to increase the usefulness of electricity to industry.

In one of these laboratories at Schenectady are nearly 70,000 square feet of floor space, with each room piped for water, gas, compressed air, vacuum, high and low pressure hydrogen, oxygen and high pressure steam, and adjoining are completely manned and equipped machine and forge shops, etc.

In this laboratory research work has been done on paints, oils and varnishes; irons, steels and alloys; copper, zinc, molybdenum and magnesium; kenotrons and pliotrons for radio work; X-ray location of holes in castings; incandescent lamps and searchlights; insulation and brush compounds; turbine blades and boiler feed water; atomic hydrogen; molecular layers in catalyzers; fuse fillers; lithium, boron, uranium and thorium; rubber and platinum substitutes, sherardizing and caloricizing, condenser, boiler and pyrometer tubes and powerful X-ray tubes.

The Amateur Magician
By JOSEPH H. KRAUS
(Continued from page 896)

ordinary blank cartridge, mounted on the base, at one end. A steel plunger, which is free to slide between two bearings; has been sharpened at one end (the end which sets off the cartridge), and has a notch filed in the rod in the other end. This notch is filed in the rod in such a way that a small, flat piece of brass (also placed in a bearing of its own) will hold the rod back until it is ready to be discharged. In other words it acts as a trigger. Around the rod is coiled a stiff piece of steel or better still, a steel spring. A flat piece of metal is then adjusted to the rod to hold the spring in place; it being held at the other extremity by the bearing. A glance at the accompanying sketch and photos will fix things clearly in your mind.

"To the trigger is attached a piece of strong silk. This is led out thru a tiny hole in the side of the bowl made for that purpose, passing thru two holes in the small one-quarter inch legs. It is then fastened to a button on the other side of the bowl.

"Before commencing the trick, a blank cartridge is prepared by first removing the hard cardboard in the end of the shell.

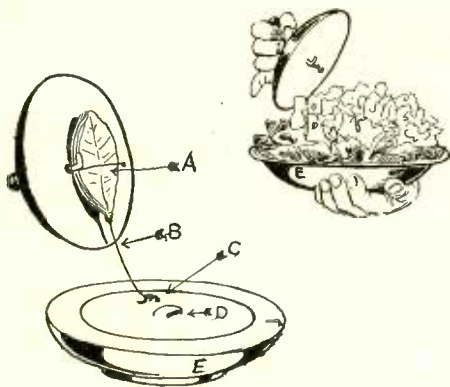

Detail of the "Fire-Bowl" Trick, Showing How the Flowers Are Concealed in a False Compartment

This is replaced with tissue paper after the powder has been loosened. It is then inserted into the holder, the spring pulled back, and the trigger set. The cotton in the bowl is now saturated with alcohol and sprinkled with ordinary salt (sodium chlorid). This gives a pretty yellowish tint to the flames, after the production of the fire bowl. The bowl is now placed in a vertical position, and the well in the center filled with alcohol so that there will be enough alcohol left to burn for quite some time.

"When the bowl is presented, it is then only necessary to pull on the string which releases the firing pin; this in turn explodes the cartridge, the latter not going off with a report—but burning like a slow flashlight powder. When this occurs, the cotton impregnated with alcohol and salt is set on fire and burns as you have just seen."

"Yes, but how about the flowers?" I intervened.

"We are just coming to that. The top as you will note is made up seemingly of one piece but in reality two. Inside the false top are arranged large quantities of silk flowers, each of which has a spring inside of it so as to insure perfect opening the moment they are released. This effect is obtained by placing the two tops on the

NAME	POSITION	SALARY
John	AUTOMOBILE ENGINEER	\$125 A WEEK
	REPAIR MAN	\$50 A WEEK
	CHAUFFEUR	\$30 A WEEK

Put Your Name On This Pay-Roll

Men like you are wanted for big-pay positions in the fascinating field of automobile engineering. We have made it easy for you to fit yourself for one of these positions. You don't have to go to school. You don't have to serve an apprenticeship. Fifteen automobile engineers and specialists have compiled a spare-time reading course that will equip you to be an automobile expert without taking any time from your present work.

AUTO BOOKS 6 Volumes Shipped Free

Now ready for you—an up-to-the-minute six-volume library on Automobile Engineering, covering the construction, care and repair of pleasure cars, motor trucks and motorcycles. Brimming over with advanced information on Lighting Systems, Garage Design and Equipment, Welding and other repair methods. Contains everything that a mechanic or an engineer or a motorcyclist or the owner or prospective owner of a motor car ought to know. Written in simple language that anybody can understand. Tastefully bound in American Morocco, flexible covers, gold stamped, 2,650 pages and 2,100 illustrations, tables and explanatory diagrams. A library that cost thousands of dollars, to compile but that comes to you free for 7 days' examination.

Partial List of Contents
More than 100 blue prints of wiring diagrams
Explosion Motors
Welding
Motor Construction and Repair
Carburetors and Settings
Valves, Cooling
Lubrication
Fly-Wheels
Clutch
Transmission
Final Drive
Steering Frames
Tires
Vulcanizing
Ignition
Starting and Lighting Systems
Shop Kinks
Commercial Garage Design and Equipment
Electrics
Storage Batteries
Care and Repair
Motorcycles
Commercial Trucks
Glossary

Only 7c a Day Not a cent to pay in advance. First you see the books in your own home or shop. Just mail coupon and pay express charges when books arrive. You can read them and study them for seven whole days before you decide whether you want to keep them or not. If you like the books send only \$2 in seven days and \$2 a month until the special introductory price of \$19.80 has been paid. (Regular price \$30.00.) Along with the set goes a year's consulting membership in the American Technical Society. (Regular price \$12.) This great bargain offer must soon be withdrawn.

Send No Money Now

Don't take our word for it. See the books without cost. There is so much profit in this offer for you, that we urge you to waste not a moment in sending for the books.

Put the coupon in the mails today. Send no money—only the coupon!



FREE!

With every set is included—FREE—a Consulting Membership which gives you the privilege of submitting your perplexing problems to a corps of experts for an entire year. This Consulting Membership regularly sells for \$12.00.

American Technical Society
Dept. A251, Chicago, Ill.

American Technical Society, Dept. A251,
Chicago, Ill.

Please send me the 6-volume set, Automobile Engineering, for 7 days' examination, shipping charges collect. If I decide to buy, I will send \$2 within 7 days and the balance at \$2 a month until the \$19.80 has been paid. Then you send me a receipt showing that the \$30.00 set of books and the \$12 Consulting Membership are mine and fully paid for. If I think I can get along without the books after the seven days' trial I will return them at your expense.

Name
Address Reference



HIGH SCHOOL COURSE IN TWO YEARS

OVER 50,000 ambitious men and women have secured better positions as a result of this course. Noted professors have specially prepared the lessons for home study—and it can be completed within two years. It is complete and covers all requirements for entrance to college, civil service positions and the leading professions. You can master every lesson without trouble. Just one or two hours a day—your spare time—and you will be mentally equipping yourself for the position you want. Without a High School training you are badly handicapped. You can't afford to overlook this essential and fundamental education—not if you wish to succeed.

Satisfaction Guaranteed

So that you may see for yourself how thorough and complete our training is—whether in our High School or any of our practical courses—we invite you to take TEN LESSONS before you decide whether you wish to continue. After the completion of ten examinations you have only to tell us you are dissatisfied with your course and your money will be refunded in full. You run no risk—so check and mail the coupon for a Free Bulletin. We employ no agents, so don't hesitate.

American School of Correspondence

Dept H-261 Chicago, U. S. A.



TRAINING—THE KEY TO SUCCESS
ASAC
Explain how I can qualify for the position checked.

- | | |
|-------------------------------|------------------------------|
|High School Graduate |Lawyer |
|Electrical Engineer |Business Manager |
|Electric Light and Power |Certified Pub. Acc't |
|Superintendent |Accountant and Auditor |
|Hydroelectric Engineer |Bookkeeper |
|Telephone Engineer |Stenographer |
|Telegraph Engineer |Fire Insurance Expert |
|Wireless Operator |Sanitary Engineer |
|Architect |Master Plumber |
|Building Contractor |Heating and Ventilating |
|Civil Engineer |Engineer |
|Structural Engineer |Automobile Engineer |
|Mechanical Engineer |Automobile Repairman |
|Shop Superintendent |Airplane Mechanic |
|Steam Engineer |Gen'l Education Courses |
|Draftsman and Designer |Common School Branches |

Name.....

Address.....

THROW YOUR VOICE



Under the table, into a trunk, down cellar or anywhere. Our lessons in VENTRILOQUISM teaches you. With our

VENTRILO
(fits in the mouth and cannot be seen) you imitate Birds, Animals, etc. without moving your lips. This outfit and book of JOKES by mail for 10c. ARDEE CO., Dept. 25, Stamford, Ct.

UMAKEM

Airplane Workbench, containing aircraft work table with mitre cutting board and length gauge, steel drill, steel hammer, Model Maker's steel square, screwdriver, sandpaper block, 10" scroll saw, together with finest quality reed and bass wood, aluminum, silk, para rubber, full set of blueprints, directions, and all fittings for building one 36" Bleriot Model flying Monoplane. Price \$10.00. Other Umakem Outfits 50c to \$50.

W. R. PRICE, Inc.
No. 2 Umakem Building, 127 Fifth Avenue, New York

bowl together. (They being held so by a hook-like affair which passes thru the bottom plate in a slot made for it, and held there by giving it a slight turn.) On removing it again only one top is taken away, thus giving rise to the rush of flowers.

"Here are a few photographs which will help make it clear, you may take them if it will help any."

Thus concluded the magician's discourse on his Fire-Bowl mystery.

AN INTERESTING CARD TRICK.

The Universal Pack: A pack of cards similar to that made by any leading magic supply house, which is universal in its use and the fake not easily detected, is made very simply. Take a deck of cards (a straight deck), which has a plain back, in other words, a back which lacks a margin. These are clamped rigidly between two blocks of wood, the latter having been shaved down so as to be quite smooth and the cards and wood all flushed together at one edge. A file is now past over the edge shaving in this way the cards and wood at the same time, thus preventing any marring or turned edges. Some very fine sand paper is now applied to the edge, finishing the job smoothly. The cards may project at one end and be filed off.

It will be noted that all the cards are narrower at one end than at the other, but only slightly so, thus making detection almost impossible. The cards are then shuffled and presented to the victim, who draws one, looks at it and replaces it in the pack, whence they are shuffled again. During the operation, however, the performer reverses the deck in his hand and when the card is replaced, it is only necessary to pass the fingers along the edges of the cards, when one card, the card chosen will be withdrawn, due to the fact that it is wider than the rest of the deck, it having been replaced in the reversed position. It is then brought to the top and may be presented in any way thought desirable.

Likewise, all four aces may be inserted into the pack, reversed of course, and completely shuffled, and with one cut may be brought to the top and dealt off. The pack can also be divided into red cards and black cards, with one cut in this case; all the red cards should be reversed before commencing the trick. After shuffling thoroly the performer runs his fingers along the edge of the cards several times to insure perfect separation, and then with one cut he is able to divide the "reds" from the "blacks".

Countless other stunts may be performed in a similar manner, taking advantage of this prepared deck.

(The next paper will appear in an early issue.)

SICKNESS OF THE ADRIATIC.

"Sickness of the Adriatic" is the name given to the phenomenon of luminosity frequently observed in the Adriatic Sea. At times its waters become phosphorescent and give beautiful reflections.

The seas around China and the Indian Ocean offer fascinating spectacles of the same character.

This liquid phosphorescence is truly bioluminescence. It is caused by a tiny protozoa, a species of fire-fly of the sea. These animalcules occasionally occur in such large mucous masses as to interfere with the efficiency of fishermen by clinging to their nets.

But this luminescence is not due to any organic decomposition or exhalations of phosphorescent gases (the vapor of phosphorous trioxide is phosphorescent). It is a sort of phosphorescence of the protozoa. Contributed by JOHN MARCHETTI.



Gee! Ain't She A Peach?

—that's what your gang'll say if you win the prize.

We'll tell the names of winners in February. The names and addresses of fellows who won prizes for giving the best uses for the

Auto-Wheel Coaster AND THE Auto-Wheel Coaster

Maybe your name will be there. Better watch. Thousands of fellows entered the contest and the judges had a hard time picking the winners. They promised to let us know in time to tell you in February.

More Prizes Coming

Now, if you or any of your gang did not win you have another chance coming. We're going to have a series of contests this year—just the kind of contests you fellows will like.



And say—the prizes you can win will make the other fellows say—"Ain't She A Peach?" Keep your eyes open for these new contests. Send for our Monthly Magazine. You will like it. It is full of contest news—how to get in on Auto-Wheel contests, with suggestions to help you win. Just give the names of three coaster dealers in your town and state which one handles the Auto-Wheel. Then we'll send the Magazine and a FREE FELT PENNANT. Also the story about organizing an Auto-Wheel Club—with FREE CAPS for all members.

Buffalo Sled Co., 163 Schenck Street, In Canada: Preston, Ont. N. Tonawanda, N. Y.

GLIDE "O" PLANE

Learn the principles of Aviation by flying our famous glide O plane. Not a toy, but a scientifically constructed gliding model, which may be thrown by hand on the field or launched from the top of the hill. Will circle, loop and glide gracefully with a light throw. Constructed of best materials, finished in bright colors with the insignia of the U. S. Army on the Main Plane. Very durable and easy to fly. All wood, adjustable. Price 55c Postpaid in U. S. Send for catalogue H3. HEC Aeroplane Co., 345 E. 49th St., New York City

Send for This Book of Model Aeroplanes

Tells how you can build and fly accurate, reduced-scale Models of real Aeroplanes; DE HAVILLAND Battle Plane, NC-4 and others. You can build one easily. Send 10c in stamps NOW and get this 48-page book. Plans for Model Aeroplanes—NC-4, 50c; DE HAVILLAND Battle Plane, Curtiss Military Tractor, Bleriot Monoplane, Nieuport Monoplane, Taube Monoplane, 35c each; Cecil Peoli Champion Racer, 25c. SEND FOR PLANS OR BOOK TODAY

IDEAL AIRPLANE & SUPPLY COMPANY
Making Model Aeroplanes Since 1911
159-161 Wooster St., Cor. W. Houston St., New York

Fun, Magic and Mystery!

56 Feats in Magic, 250 New Jokes, 21 Puzzles, 1 Fortune Telling Tablet, 52 Money-Making Secrets, 15 Card Tricks, 71 Toasts, 58 Verses in Comic Poetry, 10 Funny Readings, 41 Epitaphs, and 11 Parlor Pastimes. You get all the above-mentioned and our big illustrated Catalog of 125 Magic Tricks for only 10 cents. Write today.

MYSTIC MFG. CO.,
909 Springwells Ave., Detroit, Mich.

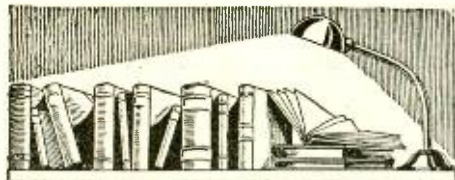

BOOK REVIEW

THE GAS MOTOR, by Max Kushlan, B.S. 366 pages, 86 illustrations, cloth bound, size 7½ x 5½ inches. Publisht by the Branch Publishing Co., Chicago.

The fundamentals of the gas motor, rather than mere structural details, are covered lucidly in this excellent book, which should find favor among all interested in automobiles, motor boats, and wherever the gas engine may be applied.

The author evidently has thoroughly surveyed his field, and selected for explanation the matters which in his opinion were of the greatest importance in placing the subject fully and clearly before the student as well as the expert.

Among the many virtues possess by the book are the questions placed at the end of each chapter, reviewing the subject matter immediately preceding it. This should prove a welcome feature.

As a practical handbook the volume has few peers. Detailed instructions for the cure of ills common to gas engines are given, as well as an appendix of useful constants and formulas.

THE MODERN MOTOR CAR, by Harold P. Manly, 536 pages, 225 illustrations, flexible leatherette bound. Publisht by Laird & Lee, Chicago. Size 5 x 7¼ inches.

"The Modern Motor Car" is announced by the publishers as a book of simplified upkeep, giving the construction, care and adjustment of motor car units, together with shop and roadside methods of trouble location and repair. There are sections on how to buy, make and use materials and supplies. Among other things, descriptions are given of the operation and repair of electric engine starters, lighting systems, magnetos and ignition parts, electric brakes, gear shifts, etc. Add to the above imposing list of attributes the fact that the book is intended for repairmen, owners, drivers, salesmen and students, and it will be evident that the field has had quite a complete consideration.

Not least interesting in the book is the section on electricity, which explains in simple manner the essential principles of the subject. As Mr. Manly says, "Without electricity, the modern gasoline automobile would be an impossibility. Electricity is used to fire the gas in the cylinders, to start the engine, to light the lamps, and, in some cars, to shift the gears, operate the horn, furnish foot and hand warmers, cigar lighters and all manner of necessities and conveniences."

This section covers 130 pages and would alone make the book a worth-while addition to anyone's technical book-shelf.

LIVING ON \$800 A YEAR. Paper cover, size 5½x7¾ inches, 16 pages. Publisht by the author, Leon Miller, Philadelphia, Pa., with an attractive cover showing his home.

The title of this book brings fond memories of a current cartoon running in the daily papers under the heading of "How Do They Do It?" Which is what we are wont to ask after reading over the author's interesting answer to the high cost of living. With the certainty of conviction, he has outlined the program of events for the entire 52 weeks of the year—food, clothes, house expenses, rent, the doctor, the butcher, the baker and candle-stick maker.

Do they have pleasure? You bet they do, and, by the way, we refer to the both halves of this marriage partnership; which is the "better-half" we don't profess to know. Probably they are still trying to settle that eternal problem. Let us not get too far away from the subject of the book, however. Among the principal schedules worked out by the author and his spouse is the "menu." We must eat, you know! Even if we live out-of-doors like the Indians. Here we find a weekly time-table, figured down to the fraction of an ounce as to what we shall have to-day, to-night, etc., etc. Looks good, but, we note that the "left-overs" of the noon meal of Sunday are disguised and used for the evening meal on Monday, and so on and so on, which gives rise to a pertinent question in our minds as to how we originally started, or whether the steak used is elastic and can be stretched to last indefinitely! From past experience we know that our better halves have often served us a "variety" that frequently needed the help of a stone-crusher, but then she's a young, sweet person, and thru our love for her we'll get a regular meal some day, provided the "book" and "our stomachs" hold out that long!

Horrors upon horrors! We overlooked the fact that the "Old Man" will give this the "once over," and if he spies that 800 bucks per annum fairy-tale, good-bye to our 100 per and the struggles of the Review Editor will cease miserably. Maybe

The machinist says:

"Sure I'm using them, the same as most of the men in the shop are doing. Some of the Starrett Tools in my kit, I bought when I was an apprentice.

"Y'see, it's like this. We got the habit when we were kids. We saw the older men, the ones that were doing the finer work, preferred Starrett Tools because they knew they were accurate, and we copied after 'em—just like our kids are doing today.

"How's that? No, I wouldn't go so far as to say that Starrett Tools by themselves will make a good machinist, but I'll say this—Starrett Tools will make it a lot easier for any machinist to do good work.

"Yes, I've got one of their 'Starrett Data Books for Machinists,' and believe me, it saves a lot of time and mistakes. If I want to know a decimal equivalent, a taper dimension, the speed of a milling cutter, or something about materials, I don't have to guess or ask—I just look in the book and find out. It set me back seventy-five cents at the hardware store, but it saved me a blame sight more than that in the first week."

The L. S. STARRETT COMPANY
THE WORLD'S GREATEST TOOLMAKERS
Manufacturers of Hack Saws Unexcelled
ATHOL, MASS

The utility and convenience of Starrett Tools are second only to their accuracy. Catalog No. 21 "LE" sent free on request.



42-972

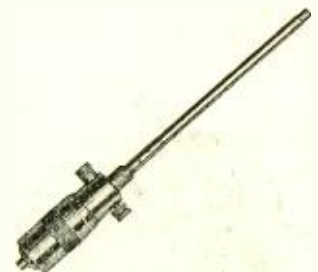

YOU can BUILD this PHONOGRAPH easily!
TREMENDOUS SAVING IN COST

You don't need to be a cabinet maker. We have made it an easy and a pleasant job with **Our Simplified Plans**. We furnish blue prints, diagrams, ready-built horn, cabinet pieces, motor, and all metal parts complete. You do the assembling. 6 models to choose from. A few hours' work, and you will have as fine a type of phonograph as any produced, and at a price away below what you would pay in a store.

Keep the Savings in Your Pocket
Machines play all records, will have a wonderful tonal quality, excelled by none. No need now for any family to be without a phonograph because of the cost. THE MAKAFONE solves the problem. BUILD IT YOURSELF AT LESS THAN ONE-FOURTH REGULAR COST, but equal to the high priced cabinet machines. Free Records with each outfit. SEND TODAY FOR FREE CATALOG and full particulars of our wonderful offer. Many a manufacturer got his start in this way. Why not you? Build machines and sell to your friends. Ask us about this.

AGENTS ATTENTION
You can make and sell this machine from our plans at a profit of \$50 to \$75 each. Others are selling two and three a week. Here is your opportunity to make big money and become independent. Pleasant and profitable work. START TODAY.

MODERN PHONOGRAPH SUPPLY CO.
143 Springer Bldg. 313 So. Clinton St., Chicago, Ill.

WRITE TODAY!
MODERN PHONOGRAPH SUPPLY CO.
143 Springer Bldg. 313 So. Clinton St., Chicago, Ill.
Gentlemen: Please send me full particulars of your interesting proposition, without obligation to me.
Name.....
Street Address.....
City or Town.....

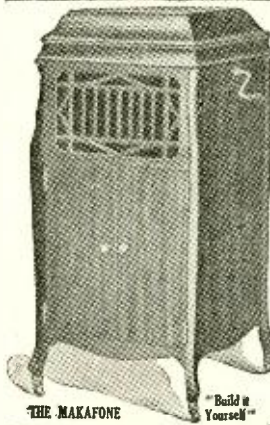

KIDPHONE

TRADE MARK

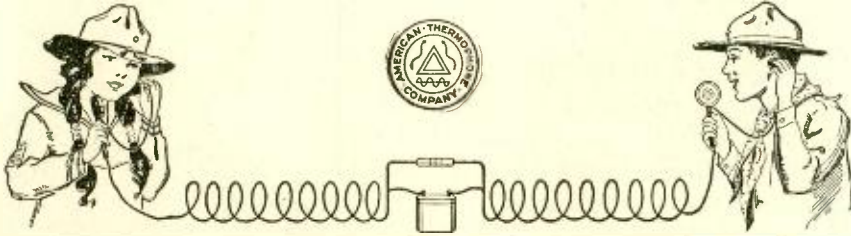

A Fascinating Toy—and More!

The Kidphone is a complete, serviceable, superior telephone, ready for immediate use—for fun or serious purpose, indoors or outdoors. Included in the set are two transmitters, two receivers, battery, and telephone wire, as well as full instructions.

Boys and girls—and grown ups, too—will marvel at the clear tones, and faithful voice reproduction of the Kidphone, yet the receiver weighs but 1/4 ounce. The idea of operation is new to America.

LET THE KIDPHONE ENTERTAIN YOU THIS WINTER
Price \$10, at your electrical dealer, department store or from us direct

Department C
AMERICAN THERMOPHONE COMPANY
114-116 Bedford Street Boston, Mass.

you would like to try out Mr. Miller's schedule—he and his wife have lived the life, you know—but remember the male gets (2) suits a year, the female gets a few odds and ends every year, whether she needs them or not; the coal? oh! a little; movies? yes; candy? smokes?—That's inhuman and uncivilized! As for us—but seriously speaking, it can be done on \$800 a year. But it requires an iron will, or rather two of them.

SPLENDORS OF THE SKY, by Isabel Martin Lewis, A.M. Cloth bound, 343 pages, 20 illustrations, size 5x7 inches. Duffield and Company, New York.

One feels satisfied and inspired after rising from a few hours spent with what is one of the most refreshing books issued during the last few years. Isabel M. Lewis, the author of that splendid book—"The Splendors of the Sky"—needs no introduction to readers of the **ELECTRICAL EXPERIMENTER**, who have enjoyed her monthly astronomical articles.

"Splendors of the Sky" is an ideal book for the seeker of astronomical information who does not wish to be encumbered with a treatise on advanced mathematics which is generally added to astronomical texts, as the unrelished seasoning to a tasty subject.

Simplicity and clarity of exposition seems to be Mrs. Lewis' aim throughout. Discoveries of the last few years are explained in such a manner as to make them palatable to every reader; there is a chapter on "Solar Explosions," sudden, but rather infrequent, appearances at the surface of the sun of hydrogen "bombs."

"These 'bombs,'" says Mrs. Lewis, "are apparently violent explosions of highly heated hydrogen gas in regions of great solar activity. At times, according to Dr. Ellerman, of the Mount Wilson Observatory, who discovered them, they will follow one another like balls of a Roman candle at intervals of ten or twenty minutes. These 'bombs' generally appear at the edge or at one side of active sun spot groups that are developing and are composed of many members. Repeated explosions often occur almost exactly in the same place."

Another interesting recent discovery discussthe existence of a tiny body two or three hundred per cent hotter than the sun, yet with a diameter only one-hundredth as great. Only two or three hundred per cent hotter, in sooth!

Besides these new things, much care is given to the regular astronomical topics. Each planet has a chapter to itself and the other bodies of this vast universe are also given justice.

But what is particularly attractive about the book is its arrangement. The chapters are not lengthy, and they are crowded full of facts more interesting than the most rampant fiction. A chapter every few nights will give anyone a practical knowledge of astronomy as it is today, and a great deal of pleasure besides.



Motors, Electrical Toys and Specialties Are Best

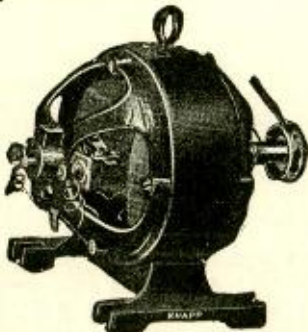

KNAPP DYNAMO MOTOR

Will electroplate, charge storage batteries, run lamps, motors, train of cars, induction coils,—in fact, the number of experiments it can be used for is unlimited. Runs on 4 to 8 Volts or can be connected to run on 110 Volts through a transformer.

Price, Complete, \$8.80

Order to-day. Or your dealer can secure them for you. **DESCRIPTIVE CIRCULAR** and **CATALOG** of celebrated **KNAPP MOTORS** and **Electrical Specialties** from 10c up mailed **FREE** on request.

KNAPP ELECTRIC & NOVELTY CO., 523 West 51st Street, New York City

Knapp Goods have stood the test for 29 years. No detail in construction has been spared to make them the best that money can buy. The complete Knapp line includes Toy and Power Motors, Generators and Dynamos, Specialties and Novelties that amuse and instruct. Fans, Rheostats, Compasses, etc. And Knapp prices are always lowest. Always insist on Knapp Goods.

KNAPP "LEADER"

An efficient and reliable motor that greatly resembles the big motors of real power plants. Drives from either pulley. Two speeds and reverse. A motor that you will be proud to own and one that will give you unlimited service.

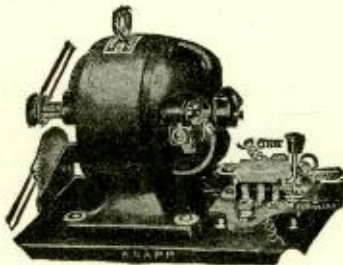

Price, Complete, \$4.40

Vertical Lighthouse Beams

(Continued from page 867)

the atmosphere is clear enough so that a fairly bright light is discernible for sixty miles or over. In surveying in the mountain regions of this country, the Geological Survey have signaled positions to each other over distances of about a hundred miles, with a small electric light operated from eight dry cells.

OLD LIGHTHOUSE HAS RANGE OF ONLY 25 MILES.

"The greatest range of any lighthouse in the world is only about 25 miles! The reason for this is very evident; the ocean is a curved surface. This curvature appears to have a remarkably short radius when one observes how quickly lighthouses disappear over the horizon viewed from the deck of a departing ship. The limitation is, therefore, geographical; it is the curvature of the earth which defines the range of a lighthouse. The only method of increasing the range is to locate the light as high above sea level as possible. The highest light in the United States is that at Cape Mendocino, California. This is four hundred and twenty-two feet above sea level, and has a range of about twenty-five miles. The Navesink Light is two hundred and forty-six feet high and has a range of about eighteen miles. In figuring the distance of the horizon from various heights above sea level, there is a simple formula which every seafaring man knows. The square root of

MODEL AIRPLANE SUPPLIES

Build and fly Model Airplanes

Send 5¢ for catalog of complete and knocked-down scale models of new machines, parts, fittings, and supplies.

Wading River Mfg. Co. 672 Broadway, Brooklyn, N.Y.

READ THE CLASSIFIED ADVERTISEMENTS
ON PAGES 963-964 and 966

the elevation above sea level in feet is approximately the distance of the horizon in miles.

"With the increasing speed of modern vessels, there is a demand for lighthouses of greater range. It is somewhat surprising to realize that the old Pharos of Alexandria had a range probably just as great as our best lighthouse of today. All of the remarkable improvements have been refinements only. The fundamental requisite of lighthouses, that is, range, has remained the same thru the past two thousand years!

THE VERTICAL SEARCHLIGHT FOR LIGHTHOUSES.

"During the war there was developed a completely new branch of illuminating engineering; this is the *anti-aircraft searchlight service*. This service gave us a great deal of new data and experience in projecting powerful lights upward into the sky. During the latter part of the war and since the war, searchlights have played the part of lighthouses for aviation and have been found to be serviceable over ranges which are unheard of in marine lighthouse practise. *Aviators have picked up the beam from a single searchlight at distances of over a hundred miles* and have been guided by it from this distance up to the searchlight beacon.

"The trans-Atlantic flight has now been accomplished by both airplane and dirigible. It is only a matter of a few years before ocean flights will become regular enough to demand beacons. It will be remembered that the NC-4 made its flight with the aid of the searchlights from the destroyers along the line of flight.

WHAT MAKES THE SKY BLUE?

"A powerful light projected vertically in the form of a narrow beam will illuminate the column of air thru which it passes, making this visible as tho it were a pillar of light. This visible beam is caused by the scattering of the light rays by the myriads of dust particles which fill the air. It is astonishing to learn that the average atmosphere, on clear days, contains about twenty thousand dust particles per cubic centimeter, whereas the air around New York City averages as high as 200,000 dust particles per cubic centimeter! Most of these particles are too minute to be visible, even under a powerful microscope, but they have, however, the property of scattering light. It is this same phenomenon which gives us our blue sky. The sun's rays, in passing thru the hundred miles of our atmosphere, are scattered in all directions by these particles and we thus receive light from all parts of the sky.

"This sky light, however, is noticeably blue in color, whereas the sunlight is a yellowish white. *The blueness of the sky is caused by the fact that these minute particles in the atmosphere scatter a larger percentage of the short blue and violet rays than they do of the longer red and yellow rays.*

WHY THE VERTICAL BEACON?

"The new Sperry high intensity electric arc is ideally suited for such vertical beacons. The requisites of a small slender beam of maximum intensity, having a bluish hue, are all met by the concentrated beam cast by this arc. Every one who has seen these bluish beams playing in the sky at night can appreciate the value that this projector will have as a beacon. The blue color of the high intensity arc has a double advantage for this service. First, a greater percentage of the rays are scattered by the dust particles in this bluish beam than is possible with any other source of light. This causes the beam to be distinctly visible. The other advantage is that the human eye is more sensitive to the blue light than to any other color when the intensities are very low. Hence, at great distances from the beacon a faint bluish color may be distinguished more easily than any other hue. Therefore, the high inten-

The Man Who *Wouldn't* Stay Down



He was putting in long hours at monotonous unskilled work. His small pay scarcely lasted from one week to the next. Pleasures were few and far between and he couldn't save a cent.

He was down—but he *wouldn't stay there!* He saw other men promoted, and he made up his mind that what they could do he could do. Then he found the *reason* they were promoted was because they had special training—an expert knowledge of some one line. So he made up his mind that he would get that kind of training.

He marked and mailed to Scranton a coupon like the one below. That was his first step upward. It brought him just the information he was looking for. He found he could get the training he needed right at home in the hours after supper. From that time on he spent part of his spare time studying.

The first reward was not long in coming—an increase in salary. Then came another. Then he was made Foreman. Now he is Superintendent with an income that means independence and all the comforts and pleasures that make life worth living.

It just shows what a man with ambition can do. And this man is only one out of hundreds of thousands who have climbed the same steps to success with the help of the International Correspondence Schools.

What about you?

Are you satisfied merely to hang on where you are or would you, too, like to have a real job and real money? It's entirely up to you. You don't *have* to stay down. You *can* climb to the position you want in the work you like best. Yes, you can! The I. C. S. are ready and anxious to come to you, wherever you are, with the very help you need.

Surely when you have an opportunity that means so much, you can't afford to let another priceless hour pass without at least finding out about it. And the way to do that is easy—without cost, without obligating yourself in any way, mark and mail this coupon.

INTERNATIONAL CORRESPONDENCE SCHOOLS
Box 6213, SCRANTON, PA.

Explain, without obligating me, how I can qualify for the position, or in the subject, before which I mark X.

- | | |
|--|--|
| <input type="checkbox"/> ELECTRICIAN | <input type="checkbox"/> MECHANICAL ENGINEER |
| <input type="checkbox"/> Electric Wiring | <input type="checkbox"/> SALESMANSHIP |
| <input type="checkbox"/> Electric Lighting | <input type="checkbox"/> ADVERTISING MAN |
| <input type="checkbox"/> Electric Car Running | <input type="checkbox"/> Show Card Writer |
| <input type="checkbox"/> Heavy Electric Traction | <input type="checkbox"/> Outdoor Sign Painter |
| <input type="checkbox"/> Electrical Draftsman | <input type="checkbox"/> RAILROADER |
| <input type="checkbox"/> Electric Machine Designer | <input type="checkbox"/> ILLUSTRATOR |
| <input type="checkbox"/> Telegraph Expert | <input type="checkbox"/> DESIGNER |
| <input type="checkbox"/> Practical Telephony | <input type="checkbox"/> BUSINESS MANAGEMENT |
| <input type="checkbox"/> MECHANICAL ENGINEER | <input type="checkbox"/> Private Secretary |
| <input type="checkbox"/> Mechanical Draftsman | <input type="checkbox"/> BOOKKEEPER |
| <input type="checkbox"/> Toolmaker | <input type="checkbox"/> Stenographer and Typist |
| <input type="checkbox"/> Ship Draftsman | <input type="checkbox"/> Cert. Pub. Accountant |
| <input type="checkbox"/> Machine Shop Practice | <input type="checkbox"/> Traffic Management |
| <input type="checkbox"/> Gas Engineer | <input type="checkbox"/> Commercial Law |
| <input type="checkbox"/> CIVIL ENGINEER | <input type="checkbox"/> GOOD ENGLISH |
| <input type="checkbox"/> Surveying and Mapping | <input type="checkbox"/> Common School Subjects |
| <input type="checkbox"/> MINE FOREMAN OR ENGR | <input type="checkbox"/> CIVIL SERVICE |
| <input type="checkbox"/> ARCHITECT | <input type="checkbox"/> Railway Mail Clerk |
| <input type="checkbox"/> Architectural Draftsman | <input type="checkbox"/> STATIONARY ENGINEER |
| <input type="checkbox"/> PLUMBING AND HEATING | <input type="checkbox"/> Textile Overseer or Supt. |
| <input type="checkbox"/> Sheet Metal Worker | <input type="checkbox"/> AGRICULTURE |
| <input type="checkbox"/> Navigator | <input type="checkbox"/> Poultry Raising |
| | <input type="checkbox"/> Automobiles |

Name _____

Present Occupation _____ 7-25-19

Street and No. _____

City _____ State _____



WHEN YOU GRADUATE From the College of Electrical Engineering

of the School of Engineering of Milwaukee with a B.S. Degree, you are thoroughly and practically trained for immediate positions of importance. Three years of intensive theoretical and practical application to purely technical electrical studies will give you a foundation upon which you can build a successful future.

ADVANCED METHODS AND SPECIAL FACILITIES combine to produce educated electrical men—a credit to their profession.

60 EXPERT SPECIALISTS in their particular lines personally guide you in the laboratory, drafting room and lecture room work of this school. Meet them at "America's Most Practical Electrical Institute."

WINTER TERM NOW OPEN
"Earn While You Learn" system. Provision for securing deficient High School credits.

Clip the coupon NOW for full information and latest bulletins FREE!
SCHOOL OF ENGINEERING OF MILWAUKEE.
151-373 Broadway, Milwaukee, Wis.

SCHOOL OF ENGINEERING OF MILWAUKEE.
151-373 Broadway, Milwaukee, Wis.

Gentlemen:—I am interested in your 3-year Electrical Engineering course with B.S. Degree. Kindly send full information and latest bulletins.

Name _____

Address _____

Age _____ Education _____

4 FAMOUS BOOKS!

THE BOOKS YOU MUST HAVE



EACH ONE A BIG SUCCESS!

Wireless Course in 20 Lessons

By S. Gernsback, A. Lescaurba and H. W. Secor, E. E.

A course that tells you everything you can possibly want to know about "Wireless" starting off in lesson No. 1 by explaining the Principles of Electricity. The second and third lessons are devoted to magnetism, motors, generators and wiring. The mysteries of "Wireless" are unfolded to you by the use of such simple language so skillfully used that of necessity you must understand every word. The subject is not treated superficially, however, for there is a whole lesson devoted to the Theory and Mathematics of this epoch marking subject. The last lesson (No. 20) is devoted to a history of Wireless.

Size of book is 7 x 10 1/4 in. 160 pages. 350 illustrations, 30 tables. Flexible cloth cover..... Per copy 75c Stiff cloth cover..... Per copy \$1.25 Postpaid

Experimental Electricity Course in 20 Lessons

By S. Gernsback and H. W. Secor, E. E.

A Course of the theory and practice of Electricity for the Experimenters. Undoubtedly one of the most complete and comprehensive treatises of this special subject ever published. Written by the same authors as the famous "Wireless Course in 20 Lessons." Every phase of experimental electricity is treated comprehensively in plain English. A book not only for the beginner but for every experimenter and student of Electricity. New Experiments are described and explained and nearly every application of Electricity in modern life is given.

The book contains 128 pages and more than 400 illustrations. Flexible cloth cover..... Per copy 75c Stiff cloth cover..... Per copy \$1.25 Postpaid

No. 1. How to Make Wireless Sending Apparatus

No. 2. How to Make Wireless Receiving Apparatus

By 20 Radio Experts
Two Remarkable Books

Book No. 1 contains 100 pages, size 7 x 5 in. and 88 illustrations. Book No. 2 contains 100 pages, size 7 x 5 in. and 90 illustrations. Both paper bound.

These two books have been written and published entirely for the wireless enthusiast who wants to make his own radio apparatus. Only strictly modern radio apparatus are described and the illustrations and descriptions are so clear and simple that no trouble will be experienced in making the instruments.

Book No. 1—How to Make Wireless Sending Apparatus 25c
Book No. 2—How to Make Wireless Receiving Apparatus 25c
Postpaid



JUST OFF THE PRESS

Design and Construction of Audion Amplifying Transformers Radio and Audio Frequency Type

This latest and important book by Mr. Edward T. Jones, late Associate Editor of *Radio News*, will be of great interest to all radio amateurs throughout the land. The transformers shown in these books have never been described in print before, and have usually been considered a manufacturer's secret. Anyone who has several vacuum tubes cannot afford to do without this book because it will enable him to build the necessary amplifying transformers very readily. The designs are very simple and rugged, and anybody can make them without much trouble whatsoever.

Mr. Jones, the author, is a practical man who is an experimenter himself and knows whereof he speaks. The book is printed on good paper and has an attractive cover in two colors. Paper bound. Size 5 in. x 7 in. Contains many illustrations, diagrams and working data necessary to build the transformers.

PRICE, Postpaid, 25c

THE EXPERIMENTER PUBL. CO., Book Dept., 233 Fulton St., New York

sity arc has the advantage at each end. It produces the most visible beam at the sending end and makes the most easily discernible beam from the distant receiving end.

"In lighthouse work the varying conditions of the weather are all important. The light that is visible thru the greatest variety of atmospheric conditions is most desirable. We have *clear weather*, *cloudy weather*, *hazy* and *foggy weather*, with which to deal.

EFFECT OF CLEAR WEATHER.

"On a perfectly clear, cloudless night the vertical beacon is somewhat faint, due to the decreased number of dust particles, but it reaches to great heights and is visible from great distances because of the clearness of the atmosphere between the beam and the observer.

"As the weather becomes a little more misty or hazy a remarkable advantage of this system is evident. The increase in particles in the beam increases its intensity and makes it more visible almost in the same proportion that the haziness decreases visibility. The pillar of light is automatic, the lower the visibility the brighter the pillar. We therefore take advantage of the very thing which tends to decrease the range and maintain the range with it.

THE VERTICAL BEACON IN FOGGY WEATHER.

"When we consider fog, the problem differs. Fog consists of small water droplets over a thousand times as large as the ever-present dust particles. When fog is heavy no light will penetrate it to any great distance, and one scheme is as futile as another. But a sea fog is not always deep; many of the fogs are low-lying blankets of mist, and it is not unusual to see the stars above on nights when lighthouses are almost useless. Under such conditions the vertical beacon has the advantage of being visible by showing its pillar above the fog where the navigators may discern it.

"Lastly, the very usual condition of cloudy weather is perhaps the most advantageous condition of all for demonstrating the efficacy of the vertical beam.

"Night clouds vary in height from half a mile to seven miles. The vertical beam produces on any cloud within ten miles above it a patch of light that is surprisingly brilliant and is visible from great distances. If the clouds were low-lying and not more than half a mile in height the brilliant patch would be visible approximately fifty miles away. When the clouds are high and dense, one hundred miles' range of visibility of the spot has been obtained.

EACH VERTICAL BEACON HAS OWN SIGNAL.

"The problem of making various beacons distinctive is much simpler than in present lighthouse practise, since any combination of dots and dashes may be mechanically signaled continually by means of a light shutter.

"The use of a shutter is impossible in present lighthouses, since only one portion of the azimuth is illuminated at one time, therefore the optical system has to rotate and the flashes are produced by the rotation of the beams in azimuth. The vertical beacon is visible in all azimuths at all times, a very great advantage.

"We have spoken mainly of the application of the beacons to sea navigation. It is almost unnecessary to enlarge upon their advantages for air travel. Inland as well as shore beacons will be required for this field to make night flying possible. Inland guide-posts of light will probably be instituted for airplanes even before the present shore lighthouses are supplemented with similar apparatus for the mariners. But the ultimate adoption of this system is more than a possibility; it is the next logical step in this period of rapid and revolutionary progress."

Electric Locos Cross Mountains

(Continued from page 874)

turns electrical energy to sub-stations to be utilized by other trains—from 25 to 52 per cent of power is recovered by regenerative braking!

MORE EFFICIENT OPERATION

The electric locomotive can be operated for a thousand miles or more with only casual inspection, whereas the steam locomotive on mountain work requires considerable attention at every division point. This has made it possible to operate the electric locomotive over several old steam divisions, and practically eliminates round-houses and yards at intermediate points.

By contrasting its workings with the steam locomotive in cold weather, as this railroad points out, the superiority of the electric locomotive is notably demonstrated. In cold weather a steam locomotive, losing much of its power thru heat radiation, draws lighter loads, makes less speed, and has greater difficulty in climbing grades and penetrating snow-drifts;—while the electric locomotive, aided by the cold in keeping its motors cool, is able to draw maximum loads, maintain its regular speed, and, by its immense power, to drive thru snow-drifts with comparative ease.

Abolishing Smoke Electrically

(Continued from page 880)

ing fine powders as in the manufacture of lamp black, zinc oxid, desiccated food, etc.

The process is generally applicable to collecting suspended solids and liquids carried in a gas. It has not yet been developed to the point where it can be used to separate gases of different constituency.

One of the interesting features of this process is that, tho originally designed simply to suppress a nuisance, it has in practise almost invariably proved a highly profitable investment, because of the value of the otherwise wasted material it recovers.

RECLAIMING COPPER FROM FLUE GASES, AT A PROFIT.

For example, a copper smelting company installed an electrical precipitation equipment at the cost of \$113,900. The operating expenses (power, labor, supplies, etc.) were \$14,600. But the value of the copper dust collected (at 12 cents a pound) was \$180,018 a year. Thus, this installation paid for itself before the year was up and thereafter operated at a magnificent profit.

Again, a cement plant has an equipment, which cost \$180,000 to install and \$10,395 a year in operating expenses. Tho the material recovered is worth much less than copper dust, its value per annum at pre-war prices was \$74,325, of which about one-third is cement dust at \$1.00 a ton and two-thirds is potash at 70 cents a unit. This also represents a highly satisfactory profit.

These examples are of large plants. However, small plants may be installed at approximately proportional cost with practically proportional recoveries, since the efficiency is not dependent upon the size of the plant, but more particularly upon the operation of it.

The ability of this process to obtain potash in commercial quantities out of the vapors from cement kilns was a genuine

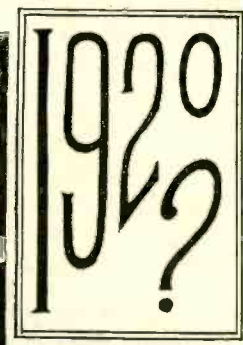

KNOWLEDGE IS POWER

A specialized electrical training, gained hand in hand with practical experience in actual laboratory work will assure for you a position of importance and responsibility in the field of mighty opportunity—*electricity!*

Let The New Year Find You Started

with the work of your choice in the large and splendidly equipped laboratories, shops, drafting rooms and class rooms of the School of Engineering of Milwaukee.

Become A Master Electrician in One Year!

The practical methods of instruction and large faculty of specialized experts of the School of Practical Electricity will prepare you in one year for highly paid positions. Countless graduates testify by their success to the actual value of the course.

School of Electrical and Mechanical Drafting

A one year course that will train you to become a first class draftsman and designer. A most practical course leading to highly paid and attractive positions.

Institute of Electrotechnics

Junior and Senior units—1½ years each—prepares for rapidly growing new field of electrical specialization. Graduates also eligible for immediate entrance to College of Electrical Engineering with B.S. Degree in 3 years.

“Earn While You Learn”

if you so desire. All of the various courses at the School of Engineering allow students part time employment either half days or alternate weeks. Thus practical experience as well as ample remuneration can be obtained.

Extension Department—Electricity, Mathematics and Drafting, Students “Frat House”—Room and board \$28.00 to \$32.50 per month. R.O.T.C. All athletics.

Spring Term Opens April 1st.

Write today for latest bulletins and full particulars.

School of Engineering of Milwaukee

152-373 Broadway
Milwaukee, Wis.

Name

Address

Education..... Age.....

I am interested in the below marked courses. Please send catalog and full particulars FREE.

- School of Practical Electricity. One Year Course.
- School of Mechanical and Electrical Drafting. One Year Course.
- Institute of Electrotechnics.
- Extension Department.
- Six Months Trade Courses.

CORE WIRE

At Pre-war Prices, 20cts. lb. This wire is just the thing for spark coils, transformers, etc., and it is, of course, a very much more superior product than the usual iron wire. We have only one size left:

24 INCHES LONG. Thickness about No. 21 B and S

If this size should be too long we advise cutting the wire down yourself by means of shears. As long as the supply lasts we offer this wire as described above to our customers at the very low price of 20¢ a pound. Add postage or we will ship express collect. Order at once.

ELECTRO IMPORTING CO., 231 Fulton Street, New York City

AMPLIFY YOUR RADIO SIGNALS

With the new DETECTAGRAPH-TRANSMITTER, the amateur can amplify radio signals to such an intensity that he can hear the signals about his station without the need of the telephone head set.

By the addition of a loud talking telephone he is able to hear the messages many feet away from the instrument.

The super-sensitive DETECTAGRAPH-TRANSMITTER herewith shown is two and three-eighths inches in diameter, five-eighths of an inch thick and weighs less than three ounces. It is the most sensitive sound detecting device ever brought before the public.

The manner in which

the amplifying process is attained is by attaching with tape the DETECTAGRAPH-TRANSMITTER to the regular wireless receiver.

Not only is this instrument applicable for amplifying radio signals, but it can be used with equal satisfaction for magnifying other sounds. Phonograph music can be transmitted from one place to another by means of this instrument, and those who are afflicted with deafness will find enormous benefit by using this transmitter. It is the greatest device for building

your own loud talking telephone, detectograph and other devices. Can be used for any purpose where a sensitive detecting instrument is required.



Our Super-Sensitive Detectograph Transmitter. Price, \$7.00 Complete

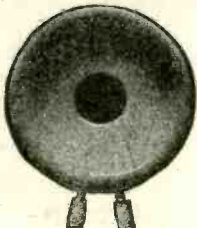

Our Special No. 25 Loud Talking Receiver. Price, \$4.50 Complete



Detectograph Rheostat, especially made for amplifying circuits. Price, \$2.00 Complete



Super-Sensitive No. 40 Receivers to be used in connection with Detectograph Transmitters, \$10.50



The Detectograph Junior Deaf-Phone \$18.00



Adjusted Model "B" Horn, with No. 20 High Grade Loud Talking Receiver, Cord Plugs and Desk Stand Base. Price, \$12.00 Complete



Adjusted Model "C" Horn, with No. 20 High Grade Loud Talking Wall Receiver, Cord Plugs and Wall Base. Price, \$12.00 Complete



Detectograph \$18.00 This detecting instrument of marvelous sensitivity can be used for detecting secret conversations. Outfit consists of Sensitive Transmitter, 25-ft. Black Cord, Receiver Headband, Case and Battery.

Equal to any \$35 instrument made. Outfit consists of Super-Sensitive Transmitter with cord connector; Super-Sensitive Ear Piece with small black cord; Black Single Headband; Black Case and Two Batteries.

Order direct from ad.
Or write for free descriptive circular.
G. BOISSONNAULT COMPANY
26 CORTLANDT STREET NEW YORK CITY
Makers of Super-Sensitive Microphone Devices

SPECIAL SALE!

We have on hand 2,000 Carbon Grain Transmitters as per photograph. They are first-class instruments and may be used for all kind of experiments, especially for wireless telephone sets, where a heavy current is to be passed through. Slightly used, but in perfect working order. Money refunded if not satisfied. A real bargain. Order one or more today.



Reduced Photograph of Transmitter showing nickel plated case and Hard Rubber Mouthpiece

\$1.00 ONLY

Postage extra.

Ship. Weight, 2 lbs.

Diameter, 3 1/4 ins.

THE ELECTRO IMPORTING CO., 231 Fulton St., NEW YORK

The Breakers

Atlantic City's Newest Fire-Proof Hotel

Ocean Front. Unusually attractive during the Autumn and Winter seasons.

American and European Plans

Luxurious lobbies, spacious verandas and sun parlors overlooking the ocean. Charming afternoon musicales and evening concerts. A palatial residence for those seeking rest and recreation. Sea water baths. Fireproof garage. Illustrated booklet sent on request.



surprise to the world and will undoubtedly have economic consequence of the greatest importance.

PRINCIPLES OF ELECTRICAL PRECIPITATION.

A treater for electrical precipitation is a comparatively simple structure. The accompanying schematic diagram illustrates a typical pipe treater. In general it consists of two large horizontal flues connected together by a number of small vertical pipes. Gases enter thru one flue, pass thru the vertical pipes and are discharged thru the other flue to a stack, exhaust fan, or other draft producer. The gas is then exhausted into the atmosphere. Some treaters are operated with an up-draft, some with a down-draft, according to the particular local conditions to be met. Some treaters employ rectangular passages instead of pipes to connect the two flues. These are generally referred to as plate or box type treaters. The principles of operation for all these types of treaters is the same.

The actual precipitation of the dust or fume occurs in the vertical pipes referred to above. Carefully centered in each, is suspended a small wire or a small chain. These constitute the *negative electrode* of the treater system. The inside surface of the pipes constitute the *positive electrode*. Each wire or chain is carefully insulated from its pipe and from the ground, and is charged to a high potential, usually at from 25,000 to 65,000 volts *direct current*. The tubes themselves are grounded. Thus, within each pipe is created an intense electrostatic field. The gases passing thru this field become ionized, and the ions travel with high velocity in a direction at right angles to the electrodes causing the field. These highly charged ions are continually colliding with the suspended solid and liquid particles in the gas, and the ions impart a charge of like potential to such particles, which in turn begin to travel toward the electrode of opposite polarity. Since the negative suspended electrode is of much smaller area than the electrode formed by the inside surface of the pipe, there is much greater electrostatic stresses per unit of area in the neighborhood of the wire, and as a result far greater ionization about the wire. Thus the gas receives a static charge of the same polarity as the wire, and the solid or liquid particles in the gas receive charges of this same polarity, which causes them to be projected against the inner surface of the pipes, where they tend to stick and accumulate until the electric power is turned off; after which the accumulation of dust is usually collected from the pipes by loosening it by rapping the sides of the pipes, and collecting the dust in hoppers at the bottom.

The treater tubes are usually arranged in a series of units. Each unit or section is independent of the rest and is supplied with dampers and electrical disconnecting switches, so that it can be shut down for cleaning or repairs, without interfering with the operation of the other sections.

To produce the high static charge on the suspended electrodes a *uni-directional current* of high voltage is used. While it is possible to generate *direct current* of a potential in the neighborhood of 100,000 volts, it is at present better practise to obtain this uni-directional high voltage current by *rectifying a high voltage alternating current*. Alternating current at low voltage is stepped up to the desired high voltage by means of a transformer and then changed into uni-directional current by means of a mechanically driven rectifier. Accordingly, the usual equipment for electrical precipitation involves the following:—A source of low voltage alternating current; a step-up transformer; a high voltage rectifier; means for driving the rectifier, also a switchboard and accessories.—Photos courtesy Westinghouse Electric & Mfg. Co.



The Electric Safety razor makes shaving a pleasure. Blade vibrating 7,200 times a minute cuts the beard smoothly and without slightest pull or irritation—feels like a gentle massage. Can be used with or without electric current.

All users of the Lek-Tro Shav speak well of it

A barber says—"Have shaved for years and have never used any shaving device near its equal."

A home user says—"The most pleasing shave I've ever had in my life. Shaves my face closer than I used to shave, but there is no after irritation or ill effects as I usually get from another razor."

No. 1 Made for use from Light Socket.
No. 2 Made for use from Dry Battery.

Write for illustrated circular describing Lek-Tro-Shav Safety Razor fully.

VIBRATING ELECTRIC RAZOR CO.

Dept. 122, Omaha, Nebr.

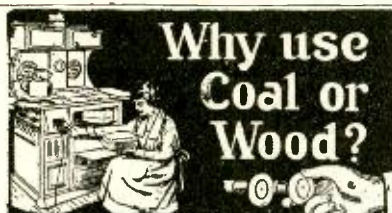

Why use Coal or Wood?

Turn a Valve and Cook or Heat

THE OLIVER OIL-GAS BURNER makes any cooking or heating stove a gas stove. Burns coal oil (kerosene). No coal or wood. Cooks and bakes better. Cheaper. Keeps your home warmer. You regulate flame. FITS ANY STOVE ANYWHERE. No fires to start, no ashes, no chopping, shoveling, poking and dragging of coal. Saves hours of work and loads of dirt. Simple. Safe. Easily put in or taken out. No damage to stove. Lasts a lifetime. Thousands of delighted users. In use eight years. Money-Back Guarantee. Free literature.

AGENTS WANTED
OLIVER OIL-GAS BURNER & MACHINE CO.,
1345 N. 7th St., St. Louis, Mo.
Western Orders Shipped From Frisco.

The Oliver Oil-Gas Burner makes 2 gals. oil equal 97 lbs. coal

ACFIELD'S METAPAD
IT SUPPORTS & BINDS
THE FRONT ARCH

Instantly Relieves Metatarsal Arch Affections
Morton Toe, cramping of toes, enlarged little toe joints, sole callouses and spreading of foot.

Worn in any Shoe, under or over stocking. Any other foot troubles?

Write for full particulars.

C.R.ACFIELD

Foot Specialties

Marbridge Building, Dept. MA 1328 B'way (at 35th St.) N.Y.

Want More Money
HERE IT IS

Hundreds of Men—elderly, young or middle aged, make BIG MONEY every month representing our magazines. Work Your Way Through College, buy the hobbies you are interested in; or go into a good paying business for yourself. You can spend all of your time or a few hours a day. You can make spending money or you can guarantee yourself a BIG INCOME.

If you can use more money and you are willing to put in a few hours a day, don't fail to investigate this offer. You will like the work and no matter what your present pursuits, your faculties will be better developed. Write to-day for full particulars.

THE EXPERIMENTER PUB. CO.
Circulation Dept., 233 Fulton Street, New York

Science In Slang

By EMERSON EASTERLING

(Continued from page 913)

or aunty's knitting thread or pop's fishing pole. Next we hear of some wise guy springing on the g.p. the tantalum. But not until we had the carbon type improved by metalization. Next, seeing that the tantalum filament was not the very best thing for Ford headlights, as it broke by looking at it too hard—and we all couldn't hold our mouth right when in its presence all the time—so the high priced metal that we extract from shelite was stuck into the vacuated glass shell—the famous tungsten. You could use the old hammer on it and still not have to bring out the oil lamp.

"Next some enterprising gink finds out that nitrogen gas works better than the absence of everything in the globe, and we get the nitrogen gas lights. By coiling the wires and thereby concentrating the light unit in the nitrogen environment, we get a glim that you can't look at and see whether she had green or just pale blue stockings until you give your headlights time to recuperate from the shock—of the light.

"That Nernst light we hear about is just oxide of Mother Earth in a few of her forms and when said earth is heated to the right temperature it becomes conductive and the juice makes it glow, like the other kind. It is a queer thing, the stuff is non-conductor when cool. Glass is the same way, only not so much so.

"The big idea in the arc lights is this: the current passing from one pole of carbon to the other particle seizes the stuff and passes it from one pole to the other. The current causes the carbon to become incandescent by way of the resistance given to the current. Some of the carbon is consumed in flame and the rest is deposited on the negative pole. In alternating current the carbon is going each way, intermittently.

"In the incandescent—so called—type the wire is heated by the juice that passes thru it, by way of the resistance in the wire, to an incandescent state. We have light.

"Is that plain?"

"Plain as broad day light," Punk returned.

"You see, in some cases, electricity flowing thru a conductor sets up resulting surrounding vibrations, sometimes in the form of light, sometimes in the form of magnetism, sometimes both. The energy that is impeded in the electrical form is converted into heat, a form of potential energy, or something else—the converting of the forces is what really impedes the current. It is the cause, not the result."

"But lissen," spoke up Punk with a dreaming, far away look in his left uppermost eye, "why has no one thot to take out a patent on a light-bulb with the vacuum on the outside!"

LONG DISTANCE RECORD IN
RADIO TRANSMISSION.

By keeping in touch with Los Angeles and San Francisco virtually during the entire voyage from Japan—sending mesages a distance of 4,855 miles—Frank Cummings and C. H. Bowers, radio operators of the Pacific Mail steamship "Columbia," claim they have established a world's record for long distance transmission of messages. They used a high-powered wireless outfit. Presumably they mean "ship to shore" transmission.

Finish This
Story For
Yourself

The girl got \$6 a week and was lonely. "Piggy"—you can imagine his kind—was waiting downstairs. He knew where champagne and music could be had. But that night she didn't go. That was Lord Kitchener's doing. But another night?



O. Henry
(12 Volumes)

tells about it in this story, with that full knowledge of women, with that frank facing of sex, and that clean mind that has endeared him to the men and women of the land.

Great Story
Writer

From the few who snapped up the first edition at \$125 a set before it was off the press, to the 120,000 who have eagerly sought the beautiful volumes offered you here— from the professional man who sits among his books to the man on the street and to the woman in every walk of life—the whole nation bows to O. Henry—and hails him with love and pride as our greatest writer of stories.

To Those Who Are Quick
JACK LONDON
5 Vols. Given Away

Never was there an offer like this. Not only do you get your 274 O. Henry stories in 12 volumes at less than others paid for one volume of the first edition, but you get Jack London's Works, 5 handsome volumes—without paying a cent. You get 17 volumes, packed with love and laughter—a big shelf full of handsome books.

SHIPPED ON APPROVAL

We will ship the two complete sets so that you can look them over in your home and then decide whether or not you wish to buy. If you are not delighted with O. Henry and the free Jack London notify us and we will take the sets back as cheerfully as we sent them. How could any proposition be more fair?

INSPECTION COUPON

THE RIVERSIDE PUBLISHING CO. (1-20)
140 So. Dearborn St., Chicago, Ill.

Please ship me on approval the Works of O. Henry, 12 volumes, New Fabrikoid binding, gold tops. Also the 5 volume set of Jack London bound in silk cloth. If I keep the books I will pay you \$1.00 as first payment within 10 days after books are received and \$2.00 per month until your special price of \$29.00 for the O. Henry set only is paid, and it is agreed I am to retain the Jack London set without charge. If not satisfactory I will notify you within 10 days and return both sets to you as soon as you give me shipping instructions as offered readers of Electrical Experimenter.

Name.....

Address.....

Business or Employer.....

Physical Perfection—Mental Alertness

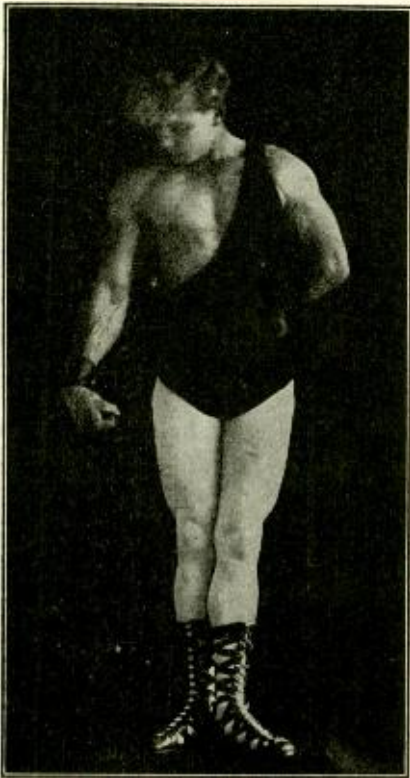

can be gained by a proper system of exercise. You will not only feel above par physically, but will also have that sense of mental alertness which is possessed only by those in the best physical condition.

This picture shows the physical development acquired by one of our pupils. His mental development is even more interesting. What he has accomplished is within the reach of every normal man and boy, through the Milo system of progressive exercises.

If you are going to exercise at all, why not go after results? You can accomplish more in three months by our system than you can in three years by any other system. During the past seventeen years we have developed thousands of men and boys, and have turned out more physical marvels than all other systems combined.

If you are interested in better health and physical and mental development, send for our illustrated catalog and folder No. 18, describing our system of training. We will show you the proofs of what our system will accomplish.

THE MILO BAR BELL CO., Third and Diamond Sts., Dept. 2. Philadelphia, Pa.

What Atomic Forces Could Do.

(Continued from page 872)

pound of coal burned in the locomotive develops 13,500 British Thermal Units. Each pound of coal thus yields 3,402,000 gram calories and for 60 tons of coal, we arrive at a total gram calorie output of 408,240,000,000. Divide this by the number of gram calories or 2,900,000,000 produced by one gram of radium disintegrating, we find that approximately five ounces of radium would be required instead of 60 tons, or 120,000 pounds of coal. This considers, of course, that we could disintegrate the radium during the trip between the two cities, so as to release all of the caloric energy in the five ounces of the stuff (based on 2,500-year decay period). The difference in weight between the coal required and the radium is almost inconceivable, so startling is the ratio between the two. Radium, of course, is very expensive at present, and this amount of radium would cost a prodigious amount of money, but presently we will undoubtedly see the cost of radium drop to a figure several thousand per cent below what it now is.

And this is not all, for we have merely used radium in this case to base our computation on for the sake of convenience. When our scientific investigators have at last solved the method for us whereby to unlock this marvelous store of energy in the atoms of any substance, then we can use an ounce of any material and not particularly radium, for as many of the world's best-known thinkers in this philosophical field have declared many times, one ounce of a certain metal, in this respect, is the same as any other substance; but the great secret, so far unsolved, is—how to overcome and control the overwhelming force with which these electrons are held in their orbits about their central nuclei.

A very small amount of coal and also a lesser amount of radium would be required to drive a railroad train from New York to Chicago, or vice versa, providing some genius will show us how to use coal, for example, to produce power in a steam locomotive without wasting about 93 per cent of it in heating and other losses. It is a well-known fact that the efficiency of the average steam locomotive is about 7 per cent. This lowly figure of 7 per cent then means that that is all of the energy put to actual work on the trip, while out of 100 per cent of the energy in the coal, when we place it in the tender car of the engine, 93 per cent is thrown away. Suppose that to-morrow an engineer produced a steam locomotive which would burn coal with an efficiency of 90 per cent; then we would only have to use approximately 1/12 of 60 tons, or 5 tons of coal! Likewise with the radium—instead of using five ounces to drive a train between the two cities, we would only require practically 5/12 of an ounce! It might be said at this juncture that, practically speaking, but a very small fraction of an ounce of radium would be required to do the work necessary to haul such a train at this rate, for undoubtedly when we once learn how to disintegrate matter after such a fashion as this, we should have available much more efficient motors, turbines and engines, etc., than we now dream of. In computing the amount of radium required, or five ounces in the present case, the amount of heat assumed as required, was that produced by the coal burning under the boiler. It will therefore be seen at once that this is really a very poor comparison so far as showing the real effectiveness of radium (or atomic energy); but as we do not have any other means of showing this ratio in a practical sense, we have to content ourselves with this illustration.

NEW MOTORS

FACTORY GUARANTEED - ALL SIZES - IN ORIGINAL BOXES

Your Opportunity

To Buy New Guaranteed Electrical Apparatus of Standard Manufacture.

<p>Single Phase Motors</p> <p>110-220 volts, A. C., 60 cycle, 1800 R. P. M. with pulley</p> <p>1/4 H. P., 110 volts, induction, full load start - \$24.50</p> <p>1/2 H. P., 110-220 volts, induction, full load start - \$38.50</p> <p>1 H. P., 110-220 volts, reputation, for compressor - \$46.50</p> <p>1 1/2 H. P., 110-220 volts, reputation, sliding base - \$67.50</p> <p>2 H. P., 110-220 volts, reputation, sliding base - \$108.50</p> <p>3 H. P., 110-220 volts, reputation, sliding base - \$124.50</p> <p>5 H. P., 110-220 volts, reputation, sliding base - \$164.50</p>	<p>Charging Generators</p> <p>Suitable for all lighting and Power Requirements.</p> <p>6 volts, 10 amp. \$16.50</p> <p>15 volts, 10 amp. \$21.00</p> <p>40 volts, 6 amp. \$24.50</p> <p>110 v, 2 1/2 amp. \$24.50</p> <p>40 volts, 12 amp. \$38.50</p> <p>110 volts, 5 amp. \$38.50</p> <p>40 volts, 25 amp. \$58.50</p> <p>110 volts, 10 amp. \$58.50</p> <p>Moving Picture Arc Generator \$85.00</p>	<p>Polyphase Motors</p> <p>2 and 3 phase, A.C., 220 v, 60 c, 1750 RPM., complete with base and pulley.</p> <p>1/2 H. P. - \$42.50</p> <p>1 H. P. - \$59.50</p> <p>2 H. P. - \$72.50</p> <p>3 H. P. - \$84.50</p> <p>5 H. P. - \$102.50</p> <p>1 H. P., high speed, 3600 R.P.M., 220 v 2 phase only - \$36.50</p>	<p>Battery Charging Outlets</p> <p>To operate on A. C., 60 cycle, single phase voltage as specified.</p> <p>110 volts, A. C., 100 watt, 24 volts, without switchboard \$40.00</p> <p>110 volts, A. C., 150 watt, 30 volts, with switchboard \$68.50</p> <p>110-220 volts, A. C., 250 watts, 24 volts, without switchboard \$75.00</p> <p>220 volts, A.C., 300 watts, 30 volts, without switchboard \$85.00</p> <p>110 volts, A.C., 375 watts, 30 volts, without switchboard \$85.00</p> <p>220 volts, A.C., 500 watts, 40 volts, with switchboard \$110.00</p> <p>110 volts, A.C., 750 watts, 72 volts, without switchboard \$125.00</p>
--	--	---	--

WRITE FOR CATALOG. BARGAINS IN MOTORS AND GENERATORS

1/4 SPECIAL

110 volts A.C., 40 c.p., 1750 RPM.

Complete, cord, plug & pulley

\$19.75

WASHING MACHINE MOTORS

Suitable for operating Small Compressors, Coffee Grinders, Bottle Washers, Etc.

Reg. Value \$22.50

EACH

MONEY BACK

GUARANTEE

SHIPPING TERMS: 25% deposit required on all orders. Balance C. O. D. by Express. Sight draft with Bill of Lading attached by freight.

MANUFACTURERS' DISTRIBUTOR

CHAS. H. JOHNSTON, Box 12 West End, Pittsburgh, Pa.

FREE! Sonora

These phonograph needles replace steel needles, play in a n y times and are used on ALL MAKES of Economical, convenient, and preserve records. 25c per card of 5, 40c in Canada. Write today for FREE sample.

Sonora Phonograph Sales Company, Inc.
 GEORGE E. BRIGHTSON, President
 279 Broadway, Dept. G, New York Toronto: Ryrie Bldg.

Send To-day for the "Electrical Worker's Friend"

An electrical book of 66 motor drawings with complete instructions for rewinding and reconnecting A.C. motors. **\$4.00**

Special at Or write for full particulars of this valuable book
SMITH & SMITH PUBLISHING CO.
 Dept. B. 1524 Lowrie St., N. S., Pittsburgh, Pa.

You benefit by mentioning the "Electrical Experimenter" when writing to advertisers.

1/2 SAVED
GET OUR
BIG BOOK

BURN LESS COAL

With an improved, all-cast pipeless furnace you can cut your coal bills in two. This efficient, basement installed heating plant heats and ventilates the entire home. It burns any grade of coal more economically than a stove. It needs no expensive piping or other equipment. Anyone can install it in a day. They are described at our wholesale prices in our Handy Man Book. Send for it.

Do Your Own Plumbing and Heating by the Cut-to-Fit Method.

By our new plan anyone can install a complete plumbing or heating plant in his own home. Send us a rough sketch with measurements. Our Engineers will draw your plans, furnish information and see that the supplies you order come CUT-TO-FIT your needs. No waste of time, labor or unused materials. Only a few simple tools necessary. Send for



The Handy Man Book

It will show you how. It will tell you just what to order and what it will cost at our wholesale prices. It contains plans and useful information for every builder, property owner or contractor. It will convince you. It will increase the value of your property 50%. You can do the work yourself.

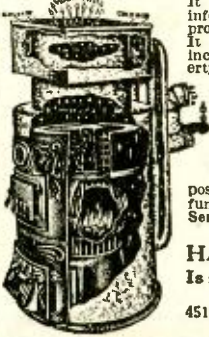

We have spared no effort or expense in the preparation of this valuable book. To keep from sending it broadcast to uninterested persons we request a temporary deposit of 25c which will be refunded with your first order. Send for it Today.

The Service of HARDIN-LAVIN CO.
Is guaranteed by 40 years' business at
4510-20B Cottage Grove Avenue
CHICAGO

HB 500 Watt Battery Charging Set

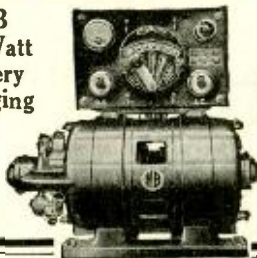

Make \$100 to \$200 Profit Every Month

Read This Record of Big Battery Charging Profits

Maxwell Garage, Lovington, Ill.: "Average weekly income from battery charging is \$40.00 to \$50.00. It costs about \$10.00 per month to run our charger." Electric Service Shop, G. W. McGee, Hamburg, N. Y.: "Average monthly expense for current, \$7.00. Average monthly income from battery charging, \$160.00." Linal Battery Co., Carlisle, Pa.: "Average monthly income from battery charging, \$133.03. Average monthly expense for current, \$21.08." Southwest Auto Electric Co., Tucson, Ariz.: "Average monthly income from battery charging, \$165.00. Average monthly expense for current, \$40.00." Adams Cooper Sales Co., Fort Smith, Ark.: "My income per month from charger is \$120.00—cost, \$16.00." Hamilton Battery Co., Hamilton, Ohio: "Income per month, \$200.00 to \$240.00—cost per month, \$15.00 to \$30.00."

You, too, can make \$100 to \$200 CLEAR PROFIT each month

This HB 500 watt charger recharges 1 to 8 6-volt batteries at once for 10c to 15c each. Customer pays \$75 to \$150. No repairs, no renewals, no expensive bulbs to burn out. Simple, sturdy, economical. Absolute money-back guarantee. Small payment brings you this money-maker, balance on easy monthly terms. Start NOW to build a big profitable battery business. Winter best time to start.

Write today for full information.
HOBBART BROS. CO., Box 11E, TROY, OHIO
Successful Manufacturers Since 1893

Telegraph Pictures BY ELECTRICITY

Complete sets of two machines of this marvelous equipment at ridiculously low prices. Instructive, mystifying and useful. This picture of President Wilson was telegraphed by these machines. Will transmit pictures, maps, drawings and hand writing. Picture telegraphing is the coming science. Write today.



J. LEISHMAN CO., Dept. T Ogden, Utah

4,000 - MILE EARTH RADIO SIGNALS.

Radiography is being revolutionized by transmission through the earth and water instead of the air, and recently gave remarkable results at a little experiment station on a barge in San Diego Bay, said Lieut. R. A. Morton, of the navy radio laboratory at Mare Island, who conducted the experiments.

First proof of the success of the new method of radio transmission thru the earth, Lieut. Morton said, was made when the Navy Department sent a message from the Annapolis station to the British admiralty that the dirigible R-34 had been sighted off the American coast.

Lieut. Morton was at his instruments, heard the messages and copied them in their entirety, he said.

A Model Helicopter

By William J. Beach, M. E.

(Continued from page 883)

would be attempting to rise vertically at the forward speed of an airplane and to dream of going up around 100 m.p.h. is rather visionary. What I claim is necessary, however, is sufficient supporting surface revolving in a circular direction at a sufficient number of miles per hour; as the aerofoil or aerofoils of an ordinary plane are taken in a forward direction at a sufficient number of miles per hour for example.

Having now described the advantages and explained the principal requirements in a vertical rising aeroplane, I will proceed to offer my suggestions as to how they may be successfully carried out and at the same time explain the principle of my invention.

As already stated I consider that there is a practicable way other than from the center axis of a motor by which a sufficient amount of surface may be rotated to rise vertically and lift into the air a useful load. This, I suggest, may be done from the outer periphery or at a sufficient distance from the center axis or axes of the motor or motors.

A simple illustration may be had from the fact that if a large wheel were mounted on a suitable axis and in suitable bearings, human strength could not turn the wheel if the energy were exerted at the axis; but once we allow the energy to be exerted at the outer periphery, then the feat becomes an easy accomplishment for human strength. The reader immediately says "Obvious"—and in saying so, agrees with me that large things are learned from small details. Having agreed that a body may be rotated from its outer periphery with a power that would be incapable of turning it from its axis, it now becomes necessary to apply that simple principle for the purposes already outlined.

According to the illustrations it will be seen that a central nacelle has a bridge-work extending transversally from it; the outer extremities of the bridge-work is provided with circular structures. Extending rearwards from the nacelle or fuselage are spars or booms which carry or support a horizontal stabilizer and a vertical fin and steering rudder.

Immediately above the two circular structures are the *uplifting surfaces* secured to central vertical shafts. The lower parts of the circular structures are provided with a track extending from the vertical shafts, on which the supporting surfaces are secured. There are also beams or the like which carry at their extreme ends suitable motors, there being two in or on each track; the motors are preferably of the rotary type and placed in an inverted manner for purposes mentioned later.



"I Can Succeed!"

"What other men have done with the help of the International Correspondence Schools, I can do. If the I. C. S. have raised the salaries of other men, they can raise mine. If they have helped others to advance, they can help me. To me, I. C. S. means 'I CAN SUCCEED.'"

Make up your mind right now that not another day shall pass until you have made *your* start toward success.

For 28 years men in offices, stores, shops, factories, mines, railroads—everywhere—have been winning promotion and increased salaries through the I. C. S. More than 100,000 men and women are getting ready *right now* with I. C. S. help for the bigger jobs ahead.

● No matter where you live, the I. C. S. will come to you. No matter what your handicaps, or how small your means, we have a plan to meet your circumstances. No matter what career you may choose, some one of the 280 I. C. S. Courses will surely suit your needs.

When everything has been made easy for you—when one hour a day spent with the I. C. S. in the quiet of your own home will bring you a bigger income, more comforts, more pleasures, all that success means—can you let another single priceless hour of spare time go to waste? Make your start right now! This is all we ask: Without cost, without obligating yourself in any way, put it up to us to prove how we can help you. Just mark and mail this coupon.

INTERNATIONAL CORRESPONDENCE SCHOOLS
BOX 6214, SCRANTON, PA.

Explain, without obligating me, how I can qualify for the position, or in the subject, before which I mark X.

- | | |
|---|---|
| <input type="checkbox"/> ELECTRICAL ENGINEER | <input type="checkbox"/> SALESMANSHIP |
| <input type="checkbox"/> Electric Lighting and Sys. | <input type="checkbox"/> Window Trimmer |
| <input type="checkbox"/> Electric Wiring | <input type="checkbox"/> ADVERTISING |
| <input type="checkbox"/> Telegraph Engineer | <input type="checkbox"/> Show Card Writer |
| <input type="checkbox"/> Telephone Work | <input type="checkbox"/> Sign Painter |
| <input type="checkbox"/> MECHANICAL ENGINEER | <input type="checkbox"/> Railroad Trainman |
| <input type="checkbox"/> Mechanical Draftsman | <input type="checkbox"/> ILLUSTRATING |
| <input type="checkbox"/> Machine Shop Practice | <input type="checkbox"/> Cartooning |
| <input type="checkbox"/> Toolmaker | <input type="checkbox"/> BUSINESS MANAGEMENT |
| <input type="checkbox"/> Gas Engine Operating | <input type="checkbox"/> Private Secretary |
| <input type="checkbox"/> CIVIL ENGINEER | <input type="checkbox"/> BOOKKEEPER |
| <input type="checkbox"/> Surveying and Mapping | <input type="checkbox"/> Stenographer and Typist |
| <input type="checkbox"/> FIRE FOREMAN or ENGR. | <input type="checkbox"/> Cert. Pub. Accountant |
| <input type="checkbox"/> STATIONARY ENGINEER | <input type="checkbox"/> TRAFFIC MANAGER |
| <input type="checkbox"/> Marine Engineer | <input type="checkbox"/> Railway Accountant |
| <input type="checkbox"/> Ship Draftsman | <input type="checkbox"/> Commercial Law |
| <input type="checkbox"/> ARCHITECT | <input type="checkbox"/> GOOD ENGLISH |
| <input type="checkbox"/> Contractor and Builder | <input type="checkbox"/> Teacher |
| <input type="checkbox"/> Architectural Draftsman | <input type="checkbox"/> Common School Subjects |
| <input type="checkbox"/> Concrete Builder | <input type="checkbox"/> Mathematics |
| <input type="checkbox"/> Structural Engineer | <input type="checkbox"/> CIVIL SERVICE |
| <input type="checkbox"/> PLUMBING and HEATING | <input type="checkbox"/> Railway Mail Clerk |
| <input type="checkbox"/> Sheet Metal Worker | <input type="checkbox"/> AUTOMOBILE OPERATING |
| <input type="checkbox"/> Textile Overseer or Supt. | <input type="checkbox"/> Auto Repairing <input type="checkbox"/> Spanish |
| <input type="checkbox"/> CHEMIST | <input type="checkbox"/> AGRICULTURE <input type="checkbox"/> French |
| <input type="checkbox"/> Navigation | <input type="checkbox"/> Poultry Raising <input type="checkbox"/> Italian |

Name _____
Present Occupation _____
Street and No. _____
City _____ State _____



In this Department we publish such matter as is of interest to inventors and particularly to those who are in doubt as to certain Patent Phases. Regular inquiries address to "Patent Advice" cannot be answered by mail free of charge. Such inquiries are published here for the benefit of all readers. If the idea is thought to be of importance, we make it a rule not to divulge all details, in order to protect the inventor as far as it is possible to do so.
Should advice be desired by mail a nominal charge of \$1.00 is made for each question. Sketches and descriptions must be clear and explicit. Only one side of sheet should be written on.

Receiver.

(365) Merle Nantz, Battle Creek, Mich., hereby presents to us a scheme and diagram for an amplifying telephone receiver. It employs a small transformer which acts upon the diafram (D) simultaneously with the polarized magnets (E M), which are energized by the current from the secondary of the transformer. In the diagram P is the primary of the transformer, S is the secondary of the transformer, P M a permanent magnet which may or may not be used. The greatest doubt is that the transformer will not be efficient enough to magnetize the electro-magnets properly.

A. We do not think that the scheme is feasible, altho theoretically there are grounds for your contention. The reason is that a telephone receiver diafram is pulled down in the exact ratio of the current supplied. Other things being equal, it will not help you to transmit the current as shown in your illustration. As long as you get a sufficient number of amperes-turns the diafram will be pulled down in a certain ratio to the current past thru the windings. Using a transformer would therefore not help you. On the contrary, due to the losses inherent in every transformer, the efficiency of the receiver would not be increased, but rather reduced.

Patents to Minors.

(366) Robert W. Ashworth, Houston, Texas, says: "I am fifteen years old and have an invention which I would like to have patented. Please let me know, if not too much trouble, how old a person has to be to apply for a patent in the United States."

A. As far as we can ascertain there is nothing in the patent laws in the United States that prevents anyone from obtaining a patent. As long as a person is the inventor of a certain device the age will make no difference and a patent will be granted, even to a minor.

This is as far as the Patent Office is concerned. It should, however, be understood that a minor would have difficulty in selling a patent until he was of age, or unless he had a guardian appointed.

Telephone Receiver.

(367) Weldon Hampton, Chicago, Ill., submits several elaborate drawings of a telephone receiver, the principle of which is shown in the illustration herewith. The inventor calls it a secondary receiver or a combination of a trans-

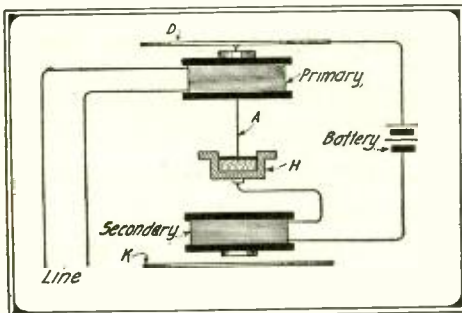

Unique Idea for a Telephone Receiver, Possessing Primary and Secondary Windings.

mitter and receiver. It may be used for reproducing the feeble vibrations in the receiver to stronger ones. From the illustration it will be seen that two diaframs are used and that the receiver has a so-called primary and secondary. The core of the primary is hollow and a fine wire A passes thru it and forms one electrode of the microphone H. The incoming line current operates the diafram D, which in turn vibrates rod A of the microphone. This operates microphone H, which in turn acts upon the secondary and the diafram K. An amplification thereby results.

A. A very clever idea, and we think that a patent can be obtained upon it. We are certain that the device works and it would come in useful for many purposes.

IGNITION DEVICE.

(368) Clyde Stewart, Beldenville, Wis., says: "I submit herewith a drawing of a proposed ignition outfit. The drawing is almost self-explanatory. The secondary coil, which could be similar to the one used on wireless spark coils is fastened firmly to the cam shaft C. The magnets N S are,

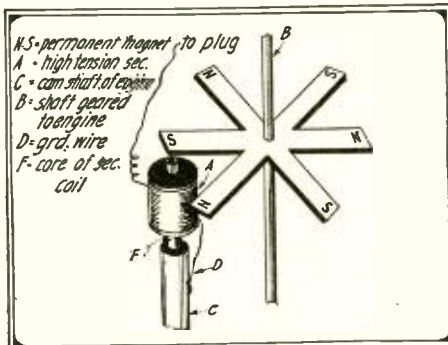

This Patent Advice Inquiry is Repeated This Month, as no Diagram was Publish with It in the December Issue.

of course, rotating all the time the engine is in operation. When the engine is on the compression stroke the cam shaft moves up, carrying the coil with it. On account of the magnetic field set up by the rotating magnets a high tension current would be set up in the coil. I am rather in doubt as to how much current could be produced, but I should think if the secondary were larger than most secondaries on gas engine coils enough current could be induced. The device could also be applied to automobile engines by means of a special device, which I have. The question of timing the discharge could be solved by moving either the coil or magnets.

A. This seems to us a good idea, altho it should be tried out first in practise. We are also afraid that more magnets than shown will have to be used in order to get a sufficiently strong spark. We also are afraid that unless the magnets are very powerful little current will be realized. When it is considered that even a small spark coil takes as much as five or six amperes it will be realized that in order to get sufficient electro-magnetic flux the permanent magnet would have to be exceedingly powerful.

U.S. PATENTS



SEND FOR THIS FORM

Don't Lose Your Rights

Before disclosing your invention to anyone send for blank form "Evidence of Conception" to be signed and witnessed. A sample form together with printed instructions will show you just how to work up your evidence and establish your rights before filing application for patent. As registered patent attorneys we represent hundreds of inventors all over the U. S. and Canada in the advancement of inventions. Our schedule of fees will be found reasonable. The form "Evidence of Conception" sample, instructions relating to obtaining of patent and schedule of fees sent upon request. Ask for them,—a post card will do.



255 OURAY BLDG., WASHINGTON, D. C.

"Originators of form Evidence of Conception"

PATENTS

TO THE MAN WITH AN IDEA

I offer a comprehensive, experienced, efficient service for his prompt, legal protection and the development of his proposition.

Send sketch, or model and description, for advice as to cost, search through prior United States patents, etc. Preliminary advice gladly furnished without charge.

My experience and familiarity with various arts frequently enable me to accurately advise clients as to probable patentability before they go to any expense.

Booklet of valuable information and form for properly disclosing your idea, free on request. Write today.

RICHARD B. OWEN, Patent Lawyer
164 Owen Building, Washington, D. C.
2276-8 Woolworth Bldg., New York City

PATENTS TRADE-MARKS AND COPYRIGHTS

Before disclosing an invention, the inventor should write for our blank form "EVIDENCE ON CONCEPTION." This should be signed and witnessed and if returned to us together with model or sketch and description of the invention we will give our opinion as to its patentable nature. Electrical cases a specialty.

Our illustrated Guide Book, "HOW TO OBTAIN A PATENT," sent Free on request. Highest References Prompt Attention Reasonable Terms

FREE COUPON VICTOR J. EVANS & CO., Patent Attorneys

Chicago Offices: 1114 Tacoma Bldg. Pittsburgh Offices: 514 Empire Bldg. Philadelphia Offices: 135 S. Broad St. New York Offices: 1001-1007 Woolworth Bldg.
MAIN OFFICES: 779 NINTH, WASHINGTON, D. C.

Name..... Address.....

? HOW TO MAKE
MONEY WITH YOUR PATENT
HOW TO SELL
HOW TO KEEP CONTROL
HOW TO ORGANIZE
HOW TO RAISE MONEY

These and hundreds of other vital questions the inventor must know to make his invention a financial success, fully answered in

The Inventors' Manual of Valuable Information
\$1.00 per copy, postpaid

If you have a patent or are thinking of taking out one, protect yourself by getting all the information this valuable book contains.

Write for free circular and table of contents.

G. E. Perry Company, Publishers, 1324 Broadway N. Y.

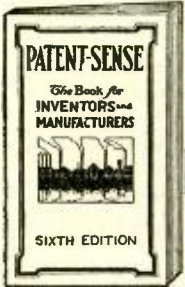

The Book
for
Inventors and
Manufacturers

SIXTH EDITION.

By return mail **FREE**.
 Write **LACEY & LACEY**
 Dept. K, Washington, D. C.

Free Book on PATENTS

Write today for a Free Copy of "How to Obtain a Patent." Contains valuable information and advice to inventors. Tells how to secure Patents. Send model or sketch of your invention for opinion of its patentable nature—Free. (20 years experience.) Talbert & Talbert, 4287 Talbert Bldg., Washington, D. C.

PATENTS

If you have an invention and desire to secure a patent, send for our Free Guide Book, **HOW TO GET YOUR PATENT**. Tells our Terms, Methods, etc. Send model or sketch and description for our opinion of its patentable nature.

RANDOLPH & CO.
 Dept. 172 Washington, D. C.

PATENTS

Record your invention. Upon request, I will forward to you my form "Fixing the Essential Dates of Invention" together with full information concerning its use and the best way to secure patent protection. Prompt, personal, efficient service, by an attorney-at-law, having over twelve years experience in patent matters. Reasonable pre-war charges. **B. P. FISHER**, 324 McGill Bldg., Washington, D. C.

PATENTS

C. L. PARKER
 Formerly Member Examining Corps, U. S. Patent Office.
PATENT LAWYER
 McGill Bldg., Washington, D. C.

Patents, Trade Marks, Copyrights, Patent Litigation

Handbook for Inventors, "Protecting, Exploiting and Selling Inventions," sent upon request.

Patents Promptly Procured

Send sketch or model for actual search of U. S. Patents. Highest references. Personal service. Moderate fees. Write for Free Patent Book.

GEORGE P. KIMMEL, Patent Lawyer
 99-B Loan & Trust Bldg. Washington, D. C.

PATENTS

Hand Books on Patents, Trade Marks, etc., sent free. Our 70 years of experience, efficient service, and fair dealing, assure fullest value and protection to the applicant. The Scientific American should be read by all inventors.

MUNN & CO., 622 Woolworth Bldg., N. Y.
 Washington Office, 622 F St., Washington, D. C.

Rotary Spark Gap.
 (369) J. Russell Franty, Du Bois, Pa., sends in to us for patent advice on the following and says: "I submit herewith a plan drawing of a rotary spark gap which embodies a new idea in the manner of connection. The object of this is to increase the number of discharges across the gap per second with the use of a smaller number of electrodes."

Referring to the drawing:
 R = rotating member. Made of bakelite or other insulating material.
 B = a ring of copper or brass surrounding R.
 C, D, E, F, G, H, I, J, K = electrodes mounted on B.
 S, S' = stationary electrodes. S and S' are similar to the revolving electrodes C, D, E, etc. S' is of a rectangular form and is slidably mounted on a stud so that it can be moved closer to or farther away from the revolving member.
 K, K' = adjusting knobs of bakelite or hard rubber.

A = stationary electrode support. It is a T-shaped member and supports the electrodes S, S'. The stationary electrodes S, S' are connected together and thence to one side of the high tension circuit. The electrode S' is connected to the other side of the circuit.

When the high tension current flows into S it jumps across the gap into C, then passes thru B into E and then jumps across a gap into S'. The rotor R moves in a clockwise direction, and when it has made 1/18 revolution the electrode G will have come opposite the electrode S', which being connected to the electrode S, will pass a current into G, thru the ring B to E and then across the gap into S'. The next spark will pass between S and K and D and S'. The same cycle of operation is repeated 18 times per second.

The advantage is due to the fact that each revolving electrode is used four times per revolution, whereas in the ordinary gap they are only

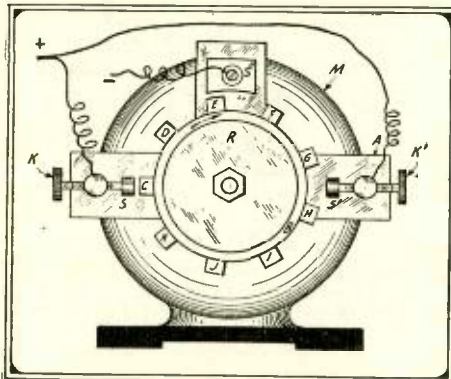

The Object of This Rotary Spark Gap is to Increase the Number of Discharges Across the Gap per Second with the Use of a Smaller Number of Electrodes than Usual.

utilized twice. Hence the discharges are twice as frequent as in the common gap.

Thus the number of revolving electrodes may be reduced and the pitch of the omitted wave still remain high.

If the number of revolutions per minute is 3600 and there are 9 electrodes on the rotating member, there will be 64,800 discharges across the gap per minute, or 1080 per second. The ordinary gap with 9 electrodes would only produce 540 discharges under the same speed.

In practice the number of revolving electrodes could be 5 or 7 and the pitch of the emitted wave will be above 600.

Please advise thru the patent advice columns of the ELECTRICAL EXPERIMENTER whether this idea would be of any practical value. Could a patent be obtained?

A. This seems to us as a very good idea and quite original to our mind. We are almost certain that a patent can be obtained on this design. At least we have never seen a gap just like this described before. As a precautionary measure, however, we would advise to have your patent attorney make a search for patentability.

FRANCE TO EXPERIMENT WITH TIDAL POWER.

Experiments to determine the practicality of the use of tidal power to offset the coal shortage under which France is expected to suffer for a long time will be carried out under government auspices in St. Briac Bay, on the north coast of Brittany.

Experiments are also being conducted to determine the possibility of replacing coal wholly or in part on the railways, in gas, water and power plants, and for domestic purposes. The *Petit Parisien* states that the use of gasoline in the chief gas, water and power plants of the public service is contemplated, and that a daily saving of 4,000 tons of coal for domestic use may result. This would require 60,000 tons of gasoline a month, possibly imported from the United States.

Competent Patent Service

By a Former Examining Official of the U. S. Patent Office

NORMAN T. WHITAKER
 Lawyer and Engineer

480 Whitaker Bldg. Washington, D. C.
 Branch Office, 52 Wall St., New York City.

INQUIRIES INVITED

PATENTS

Inventors Invited to Write for Information and Particulars
 Highest References. Best Results. Promptness Assured.

WATSON E. COLEMAN
 Patent Lawyer
 624 F Street N. W. Washington, D. C.

INVENTORS HAVEN'T YOU SOME IDEA

that you can't just work out? Give us the idea—we will develop it for you. Mechanical and electrical ideas developed. Experts in model and experimental work and in perfecting inventions. Designing and building labor-saving machinery a specialty. Get in touch with us—we can save you money.

ELK MFG. CO., INC.
 1926 Broadway, New York

MATHEMATICS MADE EASY

The Arcoscope—the Combination Triangle with a Brain—will multiply, divide, figure percentage and proportion, solve all problems in trigonometry and geometry, draw symmetrical figures, plot arcs, etc. Superior to any slide rule. Simple to operate. Also includes a **TRANSPARENT TRIANGLE, PROTRACTOR and THREE RULES** Used at Columbia University, West Point, U. S. Aeronautic Schools, etc. Only 85 cents Postpaid. Order today before you forget.

Dept. J. **L. J. LEISHMAN CO.**, Ogden, Utah

Music Lessons **Complete Conservatory Course by Mail**

At Home Wonderful home study music lessons under great American and European teachers. Endorsed by Paderewski. Masterteachers guide and coach you. Lessons a marvel of simplicity and completeness.

Any Instrument Write naming course you are interested in: Piano, Harmony, Voice, Public School Music, Violin, Cornet, Mandolin, Guitar, Banjo or Reed Organ—and we will send **FREE CATALOG**. **SEND FOR IT NOW!**

University Extension Conservatory, 6236 Slogoff-Myers Bldg., Chicago

Hang Your Own Lighting Fixtures

Semi-Bowl \$5.85. Plate & Ball 85c. 4 light shower \$5.35. Completely wired including glassware. Send for new catalogue, complete line.

ERIE FIXTURE SUPPLY CO.
 Sta. C Erie, Pa.

Electricians

Get up-to-date in **HOUSE WIRING!** Save TIME, MONEY, LABOR and MATERIAL by using our 96 **GENUINE BLUE PRINT DRAWINGS**, containing all the latest diagrams and connections known in house wiring—every diagram and connection up-to-the-minute as used by first class electricians for wiring **BELLS, BURGOLAR ALARMS, LIGHTS, ANNUNCIATORS, FIRE ALARMS and ELECTRIC GAS LIGHTING**. These drawings are bound in the form of a flexible book 19 x 12 for convenience in using on the job. Send for them, and if they don't make you more efficient as a wireman and save you many times their cost as a contractor, return them and money will be refunded—you can't afford to be without them. **ONE DOLLAR** postpaid. Send for circulars on other sets of drawings.

PATENT SPECIALTY COMPANY
 P. O. Box No. 583 San Francisco, Cal.

How to Get Rid of Moles

A simple, safe home treatment—15 years' success in my practice. Moles (also BIG growths) Dry Up.

Ask for Free Booklet of Full Particulars

WM. DAVIS, M. D.
 4140 State Street Perth Amboy, N. J.

LEARN WATCH REPAIRING

You can learn by our modern and original system of instruction every part of the Watch Repairing Trade at home as good or better than at a shop. You can earn money while learning and secure a well paying position or start in business after completing our course of instruction. Good watch repairers are always in demand and earn from \$20 to \$35 per week. For particulars apply to the

Milwaukee School of Watchmaking 166 Mason St., Milwaukee, Wis

Voice Thrower 10c
 Learn to throw your voice into a TRUNK, under the bed, out in the hall or anywhere. Lots of FUN fooling the Teacher, Janitor, Policeman, Parents, Neighbors, or Friends.

THE VENTRILO
 is a little instrument that fits into the mouth out of sight. BOYS or GIRLS can use it in conjunction with the above for imitating birds and animals. Never fails. A 32-page book on Ventriloquism sent with the Ventrilo for 10 cents.

NEW FORD JOKE BOOK 1920
 All the latest jokes on the Ford auto. Hundreds of them, and all good ones. Spring a new one on your neighbors.

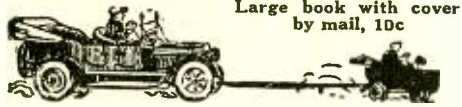

Large book with cover by mail, 10c

ROGEN X-RAY
 Price 10 cents
 HERE, BOYS, is just what you want. With this instrument you can apparently see the bones in your fingers. Think of the fun you can have with it. Sample by mail, TEN CENTS.

SKULL RING
 Here is a handsome, up-to-date Ring, representing a Skull and Cross-bones. Has stones in the eyes and looks something frightful. Women won't like it, but for men or boys it is a great novelty. Sample, by mail, 15c.

Gee! What a Wad!
 This is STAGE MONEY
 Looks like the GENUINE STUFF. Some Green backs and some Yellow backs. Create a BIG sensation among your friends. The girls will all be after you when they see the wad. BIG roll of 15 pieces by mail, 10 cents.

ENCHANTED BARREL
 The Most Wonderful Pocket Trick Made
 CHANGE A CENT INTO A DIME.
 Ask your friend to drop a dime in the barrel. When he takes it out, Behold! It is a CENT. You make 9 cents every time you fool them. Never fails. They cannot rest on it. Sample barrel, with directions, only.... 10c

Hindso Flower Pot Trick
 You have all heard of the great Hindoo trick (making a plant grow out of a flower pot right in front of an audience). This trick has puzzled the whole world for years until an old Hindoo fakir gave it away. We send the whole outfit by mail with full instructions for 15 cents.

BIG VALUE for 10 Cts.
 6 Songs, words and music; 25 Pictures Pretty Girls; 40 Ways to Make Money; 1 Magic Book; 1 Book Letter Writing; 1 Dream Book and Fortune Teller; 1 Cook Book; 1 Baseball Book, giving rules for games; 1 Toy Maker Book; Language of Flowers; 1 Morse Telegraph Alphabet; 12 Chemical Experiments; Magic Age Table; Great North Pole Game; 100 Conundrums; 5 Puzzles; 12 Games; 30 Verses for Autograph Albums. All the above by mail for 10c.

Trumpet in Handkerchief
 The Trumpet in the Handkerchief has come to torment us. It is a starter. A small metal trumpet is ingeniously concealed in a handkerchief. On meeting your friends, after chatting awhile, you take out this handkerchief and blow your nose. It's like a sudden clap of thunder! The ladies scream, and your male friends will think they heard the whistle of a steam engine. You can blame the hideous noise to your having a very bad cold, and keep the fun up as long as you like. Price, 10c, 3 for 25 cents, by mail.

Any 3 for 30c Mailed with Catalog
ROYAL NOVELTY COMPANY
 415 East Ave., South Norwalk, Conn.

Swimming Pool Purified by Electric Rays.
 By JOSEPH H. KRAUS
 (Continued from page 877)

A person is instantly impressed by the bright blue glow at the far end of the pool and going over to investigate, sees the sterilizer. Looking into the pool he can see the bottom thru eight feet of water as clearly as tho he were looking into a finely polished glass, and ah! what confidence he has in "taking a duck" in the inviting waters glittering and sparkling in their purity.

The device is constructed very simply. It consists of a tank of non-ponderous proportion, which tank contains three compartments. Between the vanes which divide the compartments is an opening, allowing for the insertion of the ultra-violet ray lamp,—the water in order to flow from one of the compartments to the other, must pass two of these lamps. The drain-pipe successfully prevents the overflow of the water above the compartment vanes. In this way all of the water must pass over or under the sterilizer at least twice. The water constantly going in, forces the rest of the water along, and inasmuch as the last compartment has a low vane or partition, a miniature water fall is produced. The water then passes into the pool thru the supply outlet pipe. The tank can sterilize about 300 gallons of water per hour, and perhaps even more may be obtained from it.

Astern! With Engine Running Ahead.
 (Continued from page 885)

How easily this maneuver is executed is proven by the remarkable triple exposure photograph here reproduced. This picture shows three exposures on one plate depicting the Landreth Motor-boat turning in approximately its own length while traveling "full speed" ahead! The exposures were made a few seconds apart and the boat made a complete turn in approximately twenty seconds!

With a few turns of the wheels the rudder plates are set in V-shape, as illustrated in the chart and with the propeller running full speed ahead, the boat almost instantly stops and starts to run backward. The boat was brought from full speed forward to backing in 9 seconds. With the reversing gear originally installed on this boat it took 26 seconds to back. The reversing speed can be controlled to any degree by increasing or decreasing the angular positions of the rudders. The reversing motion is imparted by a stream of water thrown back against the rudder by the propeller and projected thereby forward along the sides of the boat toward the bow. The speed of this water is sufficient to propel the boat backward at about 30 per cent of the full speed ahead. Just how this is accomplished is shown in the accompanying detail drawing. It will be noted that there is a steel plate, or fin, above the rudder which prevents the water thrown back by the propeller to escape over the top of the rudder. This fin assists in directing the water forward along the sides of the boat.

The manner in which this experimental boat was equipped with the new rudder is shown in the photos herewith. It was discovered in these experiments that the angle of the supporting rod must be 90 degrees, or more, with the propeller shaft.—Photos courtesy of General Electric Co.



THE HEART OF THE HAMMOND Interchangeable Type

One of the Greatest Achievements of Science and Invention.



"Many Typewriters In One"

For the Mathematician, Engineer, Chemist, Astronomer, Surveyor, Navigator—there is no typewriter like the Multiplex Hammond! The Multiplex does many things that no other typewriter can do!

The Mathematical Multiplex contains the characters and signs used for writing in higher and lower mathematics, and for engineering, mechanics, etc., as well as for all the ordinary work that can be done on any typewriter. Just note these fine styles of Multiplex type—

TWO STYLES OF TYPE, or two to five different languages, carried on the machine AT ONCE. "JUST TURN THE KNOB" and change instantly from Roman Type, to Italics, or Miniature Roman, or our Beautiful Script Type, or from English to Greek, Russian, German, French, etc. Any other type or language can be substituted in a few seconds.

The above gives a slight idea of the versatility of the Multiplex which has literally revolutionized typewriting—has changed it from monotonous commercial work to the beauty of fine printing and engraving.

WRITE FOR FREE BOOKLET showing the many languages and type sets of the Multiplex—there's a type for every profession, every business, every science, including technical signs and symbols and chemical keyboard.

Fill out the Coupon and mail to us now—before you turn this page and possibly forget. You incur no obligation.



Also—an Aluminum PORTABLE Model

For Traveling—for home. Weighs about 11-lbs. Full capacity. Ask for special folder.

THE HAMMOND TYPEWRITER CO.
 589 East 69th Street New York City

Name

Address

.....
 Please write your occupation below.

BOYS



Learn Drafting

Employers everywhere are looking for skilled draftsmen. They are offering good salaries to start with, splendid chances for advancement.

Drafting offers exceptional opportunities to a young man because drafting itself not only commands good pay, but it is the first step toward success in Mechanical or Structural Engineering or Architecture. And drafting is just the kind of work a boy likes to do. There is an easy, delightful way in which you can learn right at home in spare time. For 27 years the International Correspondence Schools have been giving boys just the training they need for success in Drafting and more than 200 other subjects. Thousands of boys have stepped into good positions through I. C. S. help, but never were opportunities so great as now.

Let the I. C. S. help you. Choose the work you like best in the coupon, then mark and mail it. This doesn't obligate you in the least and will bring you information that may start you on a successful career. This is your chance. Don't let it slip by. Mark and mail this coupon now.

INTERNATIONAL CORRESPONDENCE SCHOOLS BOX 6215, SCRANTON, PA.

Explain, without obligating me, how I can qualify for the position, or in the subject, before which I mark X.

- | | |
|---|---|
| <input type="checkbox"/> MECHANICAL DRAFTING | <input type="checkbox"/> SALESMANSHIP |
| <input type="checkbox"/> STRUCTURAL DRAFTING | <input type="checkbox"/> ADVERTISING |
| <input type="checkbox"/> SHIP DRAFTING | <input type="checkbox"/> Show Card Writer |
| <input type="checkbox"/> ELECTRICAL DRAFTING | <input type="checkbox"/> Sign Painter |
| <input type="checkbox"/> ARCHITECTURAL DRAFTING | <input type="checkbox"/> ILLUSTRATING |
| <input type="checkbox"/> SHEET METAL DRAFTING | <input type="checkbox"/> Cartooning |
| <input type="checkbox"/> ROOFER DRAFTING | <input type="checkbox"/> BUSINESS MANAGEMENT |
| <input type="checkbox"/> BRIDGE DRAFTING | <input type="checkbox"/> Private Secretary |
| <input type="checkbox"/> MACHINE DESIGN | <input type="checkbox"/> BOOKKEEPER |
| <input type="checkbox"/> ELECTRICAL ENGINEER | <input type="checkbox"/> Stenographer and Typist |
| <input type="checkbox"/> Electric Lighting and Railways | <input type="checkbox"/> Cert. Public Accountant |
| <input type="checkbox"/> Electric Wiring | <input type="checkbox"/> TRAFFIC MANAGER |
| <input type="checkbox"/> Telephone Engineer | <input type="checkbox"/> Railway Accountant |
| <input type="checkbox"/> MECHANICAL ENGINEER | <input type="checkbox"/> GOOD ENGLISH |
| <input type="checkbox"/> Machine Shop Practice | <input type="checkbox"/> Teacher |
| <input type="checkbox"/> Gas Engine Operating | <input type="checkbox"/> Common School Subjects |
| <input type="checkbox"/> CIVIL ENGINEER | <input type="checkbox"/> MATHEMATICS |
| <input type="checkbox"/> Surveying and Mapping | <input type="checkbox"/> CIVIL SERVICE |
| <input type="checkbox"/> STATIONARY ENGINEER | <input type="checkbox"/> Railway Mail Clerk |
| <input type="checkbox"/> Marine Engineer | <input type="checkbox"/> AUTOMOBILE OPERATING |
| <input type="checkbox"/> ARCHITECT | <input type="checkbox"/> Auto Repairing |
| <input type="checkbox"/> Contractor and Builder | <input type="checkbox"/> PLUMBING AND HEATING |
| <input type="checkbox"/> Concrete Builder | <input type="checkbox"/> Textile Overseer or Supt. |
| <input type="checkbox"/> Structural Engineers | <input type="checkbox"/> Navigation <input type="checkbox"/> Spanish |
| <input type="checkbox"/> CHEMIST | <input type="checkbox"/> AGRICULTURE <input type="checkbox"/> French |
| | <input type="checkbox"/> Poultry Raising <input type="checkbox"/> Italian |

Name _____
 Present Occupation _____ 7-28-10
 Street and No. _____
 City _____ State _____

NO CARBON—MORE POWER—LESS FUEL Price 50¢ up

"NO-LEAK-O"

On market 5 years. Over 10,000,000 in use. Every set guaranteed. Popular thru service. Don't rebore cylinders. "NO-LEAK-O" makes good when others fail. Made different. Give results different. Order from nearest jobber, or write direct.

NO-LEAK-O PISTON RING CO., Baltimore, Md.
 Beware of imitations. See that NO-LEAK-O is on EVERY PACKAGE.

Learn Autos and Tractors

Wonderful opportunities constantly offered trained men; we train you thoroughly to start your own business or make good money as motor expert, driver, shop foreman, etc.

5000 Graduates making good. Catalog Free.

Cleveland Automobile School, 1807 E. 24th St., Cleveland, O.

STAMMERER

Send 10 cents for my remarkable book, "How To Stop Stammering." Kill the fear of stammering. Re education the key.

The Hatfield Institute, 109 N. Dearborn St., Chicago, Ill.

DR. J. H. ROGERS URGED FOR NOBEL PRIZE.

A cablegram sent recently to Stockholm, Sweden, may secure for Dr. James Harris Rogers of "Underground Radio" fame, an honor which he well deserves and a reward that he has spent a lifetime in earning. The cablegram follows:

*Committee on Award of Nobel Prize in Physics,
 Royal Academy of Science,
 Stockholm, Sweden.*

We ask consideration in award of prize in physics for Dr. James Harris Rogers, Hyattsville, Md., discoverer of underground and undersea wireless. Details obtainable from *Baltimore Sun*, Southern Commercial Congress, United States Senator France, Georgetown University.

[Signed.]
 MARYLAND ACADEMY OF SCIENCES,
 FRANCIS C. NICHOLAS, Director.

While all the scientific world concedes that Dr. Rogers discovered, revealed and put to immediate practical use a secret that Nature had hitherto concealed, no one happened to think, before *The Baltimore Sun* suggested it, of the Nobel prize in physics as a reward for his achievement.

The Nobel Prize Fund is administered by a board of trustees at Stockholm, and the income from it is divided into five equal sums, of about \$40,000 each, to be awarded annually December 10, the anniversary of the donor's death, and to be known as the Nobel Prizes. The prizes are conferred for what is considered the greatest work of the year in chemistry, in physics, in medicine or physiology, in idealistic literature and in the furtherance of the world's peace. The trustees do not make the awards, but have designated various educational institutions of Sweden to make them. The Royal Academy of Science, Stockholm, is chosen to award the prize in chemistry and that in physics.

Thus far only three persons in America have won Nobel prizes. The late President Theodore Roosevelt was chosen for his share in bringing about peace between Russia and Japan in 1906; Dr. Albert A. Michelson, of Chicago, a German by birth but a resident of the United States and a graduate of the Naval Academy, won the physics prize in 1908, and Senator Elihu Root received the Nobel Peace Prize for 1912 because of his work in the pacification of Cuba and the Philippines.

No Nobel prize has been awarded in physics since 1915 owing to the war.

Dr. James Harris Rogers, of Hyattsville, inventor of the underground and undersea wireless system of telegraphy, regarded as one of America's greatest war inventions, has made a discovery in physics and perfected a practical invention that makes him today a central figure in the scientific world. It is a discovery that gave the United States opportunity successfully to transport American troops to the Continent and to continue to receive, continuously, telegraph messages from Europe after Atlantic cables had been cut.

PLAN SERIES OF RADIO STATIONS.

The Y. M. C. A. Radio Club of Sioux Falls, S. D., is very active. At present the club has 32 members and more are joining daily.

Since the organization of the club a short while ago lessons have been given regularly in the code and the fundamental points of wireless, including construction of radio stations and the use of the apparatus in connection therewith.

With the establishment of several wireless stations about the city, it is hoped that the club will become more interesting and have a greater appeal to the boys of the city. The varied phases of communication present many opportunities for developing interest and knowledge of the subject.

Radio Diagrams and Formulae in Loose Leaf Form

The publishers of the CONSOLIDATED RADIO CALL BOOK have completed the preparation of diagrams and instructions on:

- Measurement of Capacity of a Condenser. (Substitution Method.) Calibration of a Variable Condenser. Two Diagrams and Curve. No. 1
- Measurement of Inductance of a Coil or Circuit. Two Methods—Two Diagrams. No. 2
- Measurement of Distributed Capacity of an Inductance. Diagram and Curve. No. 3
- Measurement of Fundamental Wavelength of an Antenna. Three Methods. Three Diagrams. No. 4
- Measurement of Wavelength of Distant Transmitting Station. Two Methods. Calibration of a Receiving Set. Two Diagrams. No. 5
- Measurement of Effective Antenna Capacity. Two Methods. Two Diagrams. No. 6
- Measurement of Inductance of Antenna and a Third Method of Measuring Effective Capacity of Antenna. One Diagram. No. 7
- Measurement of Antenna Resistance. Substitution Method. No. 8
- Schematic Wiring Diagram of Regenerative Audion Receiving Set Suitable for Receiving High Power Undamped Wave Stations. Connections shown are those used in most Navy and Commercial Receivers. No. 50
- Table giving the value of LC (Product of Inductance and Capacity) for wavelengths from 300 to 20,000 meters. Inductance in Microhenrys. No. 100
- Table same as above but with Inductance in centimeters. No. 101
- Schematic Wiring Diagram of Signal Corps Type SCR-68 Radio Telephone Transmitting and Receiving Set. No. 51
- Schematic Wiring Diagram of Type CW-936 (Navy Submarine Chaser) Radio Telephone and Telegraph Transmitter and Receiver. No. 52
- Schematic Diagram of Type S.E. 1100 (Navy Flying Boat) Radio Telephone and Telegraph Transmitter. No. 53

These diagrams and instructions are the most CLEAR, CONCISE, COMPREHENSIVE and CONVENIENT form of instruction that has ever been presented. They are printed on pages size 8 1/2 x 11.

Complete Set of 14 Sheets **75c**

as described, sent postpaid
 CONSOLIDATED RADIO CALL BOOK CO., Inc.
 41 Park Row, New York, N. Y.

35 Miles per hour
 Is Record of this Car

Boys, Build This Car. This nifty little car driven by gasoline motor, can be built by any boy. Parts are furnished by us and are very cheap. Send 25c for building plans and price list of parts showing how to build this lad's car.

SYPHER MFG. CO.
 156 Warren Street
 TOLEDO, OHIO.

DONINGER WILL SAVE

\$40 BIG MONEY SAVINGS FOR YOU

Used and rebuilt motorcycles, single and twins; \$25 to \$100. Used bicycles \$5.00; tandems \$10. All machines guaranteed to good working order. New bicycles and motorcycles at Factory prices. You save dealers' profit. Also Motorcycles and automobile tires too, \$3.00. Complete line car parts and supplies.

Send for catalogue
Doninger's Cycle Co., Rochester, N.Y.

YOU 25 TO 50 DOLLARS

SMALL ENGINES

Perfected Gasoline Engines—1/2, 1 and 1 1/2 h. p.—for Farm and Shop use. Price, \$27.50 and up. Also

WASHING MACHINES

We ship on trial. Send for Booklet and Special Offer.

SIEVERKROPP ENGINE CO.
 1401—19th St., Racine, Wis.

STARTER for FORD CARS

INDEX to Volumes 1, 2, 3, 4, 5

ELECTRICAL EXPERIMENTER

Contains 24 pages and shows every article of interest that has been published since the inception of the magazine up to and including April, 1918. It is absolutely indispensable to everybody interested in any kind of electrical research work.

Postpaid 15c

Experimenter Publishing Co., 231 Fulton St., N. Y. C.

THE HEART OF THE WIRELESS

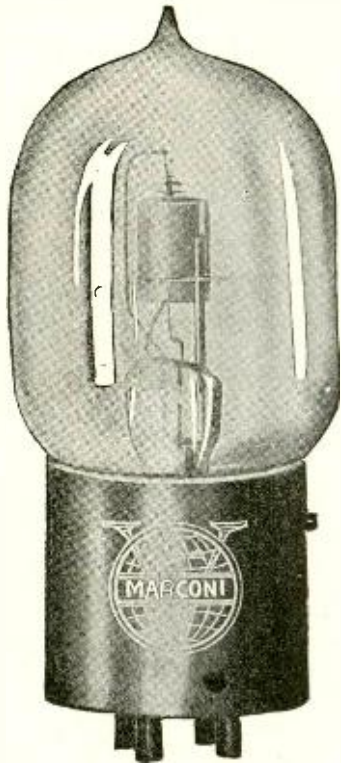

Fleming Pat. No. 803684
De Forest Pat. Nos. 841387-879532

*An Amateur Station
Without a Vacuum Tube
is Years Behind the Times*

MARCONI V.T.

\$7.00 each

Under agreements recently effected the Marconi V. T. is the only vacuum tube, or audion, which may be sold to amateurs, laboratories, schools of instruction and experimenters.

The approximate operating life of the MARCONI V. T. is 1,500 hours.

FEDERAL-AUDIO FREQUENCY TRANSFORMER

Designed for use with the Marconi V. T.

\$7.10

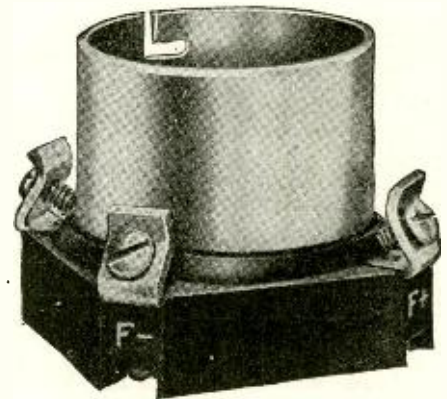

Standardized Socket \$1.50 additional

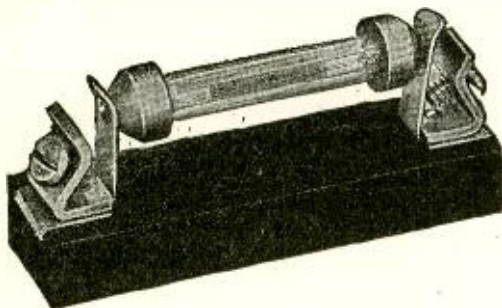

Standard Resistance, Complete \$1.00

The Marconi Resistance, connected in the circuit between the grid and the filament of the Marconi V. T., is made in the following standard sizes:

1/2 megohm, 1 megohm, 2 megohms, 4 megohms, 6 megohms.

Resistances of any special fractional values up to 6 megohms can be supplied.

Send all remittances with order to **COMMERCIAL DEPARTMENT**

MARCONI WIRELESS TELEGRAPH CO. OF AMERICA

235 BROADWAY, NEW YORK

Retail Office and Exhibition Rooms—25 Elm Street, New York

Sole Distributors for De Forest Radio Telephone & Telegraph Co.

BRANCH OFFICES:

Schofield Bldg., Cleveland, Ohio
American Bldg., Baltimore, Md.

Insurance Exch. Bldg., San Francisco, Cal.
136 Federal St., Boston, Mass.

301 Commercial Bank Annex, New Orleans, La.
109 South 2nd St., Philadelphia, Pa.

WIRELESS MEN and AMATEURS

The Second Edition of the
**Consolidated
Radio
Call Book**

Will Be Out Feb. 5



The only book in print officially listing all the amateur radio calls as issued by the Bureau of Commerce. Meets a timely and urgent necessity among radio and steamship companies, professional and amateur radio operators, and those having need of authentic and practical information on radio calls; radio, telegraph and cable rates, special signals and general radio procedure.

All Amateur Calls Listed

In addition every vessel and land station in the world is represented and listed alphabetically, according to names of vessels or land stations, and according to call letters; Revision of American coastal stations under U. S. Naval control, and their new calls.

That new and great aid to navigation—the radio compass—is explained and is a unique feature of this publication which will be of special value to masters of merchant vessels. This book contains all calls listed in the new book to be published by the Department of Commerce.

Price \$1.00 Prepaid

IMPORTANT **NEW**
Given Free with Each Copy

A Wireless Map of the World in colors is given absolutely free with each copy. This map shows the locations of all the high powered RADIO stations in the world, including the time signal stations. In addition it tells at a glance how far away any of these stations are. Of greater interest are the time zones, which enable the amateur to compute instantly the correct time for the zone in which he is located from any time signal station.

Order Your Copy Today

Send Cash, Money Order or Check. Act quickly, as orders are pouring in and the edition will be rapidly exhausted. All orders filled in the order of their receipt and first come, first served.

Consolidated Radio Call Book Co., Inc.
41 Park Row, New York City

This book also contains the advertisements of practically every leading company in the radio field.

The Mt. Wilson 100-Inch Reflecting Telescope

(Continued from page 889)

effect it, however, and even the heat from the friction of grinding made it necessary each day to discontinue work after a couple of hours. Another most elaborate series of tests was made each day to determine the effect of the previous day's grinding on the optical qualities of the glass. To carry out these tests a 60-inch plane mirror was required, the grinding of which took nearly a year in itself.

HUGE LENS MIRROR WEIGHS 9,000 LBS., OR 4½ TONS.

When the polishing was complete the huge mirror was 12¾ inches thick at the edge, 101 inches in diameter and weighed 9,000 pounds. The surface is slightly parabolic and yet at its center differs from a true spherical form by only .001 of an inch. A deviation of more than .000,004 of an inch from the theoretical form calculated by the mathematician was positively not permissible. Imperfections so minute are discovered by exploring the surface of the disc with a ray of light and it was for this purpose that the 60-inch plane mirror was required. And thru the center of this wonderful mirror a hole, several inches in diameter, is drilled. This is used for viewing the image thru, as explained later on.

In the spring of 1917, eleven years after the order was given for the casting of the glass, and seven years after the grinding began the mirror was pronounced fit for use and it was therefore silvered. The area of its surface is 8,012 square inches and the operation of silvering required 150 gallons of distilled water and 32 ounces of silver nitrat. In 15 minutes the deposition of silver was complete.

For use in conjunction with the larger mirror two convex mirrors also had to be ground. These mirrors were of 29 and 25 inches aperture respectively and when combined with the larger mirror increase its focal length from 42 feet 3½ inches to 150 and 251 feet.

In the meantime other and equally important operations were in progress, for telescope mirrors are useless without proper mounting and housing. The dome of the observatory built contemporaneously with the grinding of the mirror is 100 feet in diameter and 100 feet high. In its construction 650 tons of steel were used, all of which had to be transported to the summit of Mount Wilson, 6,000 feet high. To permit this it was necessary to widen the mountain road from 3 to 8 feet. Motor trucks having extra water supply to prevent overheating on the steep grades were found necessary and 6 months were required to get the materials to the top. The larger parts of the telescope mounting were made in the Fore River Ship-yard at Quincy, Mass., and the dome was built by the Morava Construction Works of Chicago.

The dome is made of metal and is double-walled to insure more uniform temperature. The greater portion of the dome rotates, only the lower 28 feet being stationary. A huge central pier, surrounded by 40 others, comprises the foundation for the telescope mounting. Underneath the main pier is a 6-foot depth of sand. This pier is of solid concrete and hollow. At the level of the ground it is 20 feet by 45 feet and rises to a height of 33 feet. In it are three heavy floors, the uppermost of which at a level of 25 feet houses the driving clock and other parts of the mechanism. The pier is surmounted by a circular floor 52 feet in diameter. To exclude

(Continued on page 944)

MAGNAVOX

Telemegafone

FOR RADIO RECEIVING

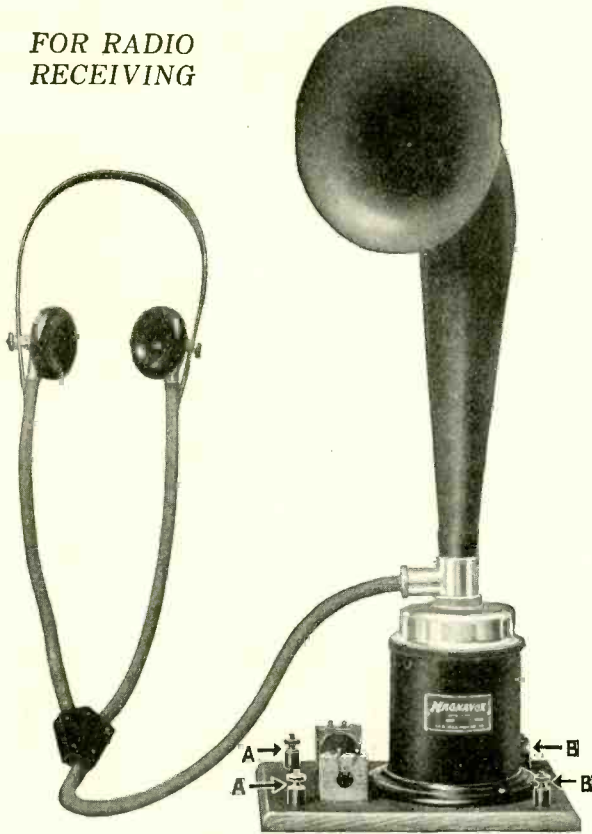

PRICE \$75.00

Connect AA to Radio Receiver and BB to 6-volt storage battery

The Most Efficient Telephone Receiver and Loud Speaker

The most rugged, simple and reliable instrument yet produced for the reproduction of sound

For Radio, it is not only a most sensitive receiver when used with the head-set, but is also the most powerful loud speaker manufactured.

The powerful Magnavox Telemegafone fills a long felt need of public speakers and places of amusement.

The Magnavox Telemegafone enabled President Wilson to speak to 50,000 people at San Diego. The President's Victory Loan message was transmitted by radio telephone from an airplane and reproduced by the Magnavox Telemegafone to 20,000 people assembled in front of the Treasury Building at Washington, D. C.

Immediate Deliveries — Send for Bulletin

FOR MUSIC AND VOICE



PRICE \$150.00

With attachment for Phonograph as shown Operates from 6-volt storage battery



PATENTED IN U.S.A AND FOREIGN COUNTRIES

2701-2759 East Fourteenth Street
Oakland, California

Mesco Radio Buzzer

With Shunt Resistance —
U. S. Navy and U. S. Army Standard

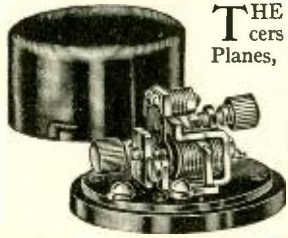

THE Radio Officers of the NC Planes, after testing all other buzzers, decided to use the "Mesco" on their radio equipment. The R-34 was equipped with two Mesco Radio Buzzers.

Why? Because of its reliability and constancy in operation; greater output efficiency; ease of adjustment; unaffected by extreme variations in weather conditions; exposed wires eliminated.

Sparking is almost entirely eliminated, so that the energy lost in light and heat in the operation of other buzzers is here conserved and radiated in the form of oscillating energy.

This buzzer maintains a constant note and is recommended as an exciter for checking wavemeters where pure note and ample energy are required.

List No. 55, Mesco Radio Buzzer
Price \$2.05

MESCO WIRELESS PRACTICE SET

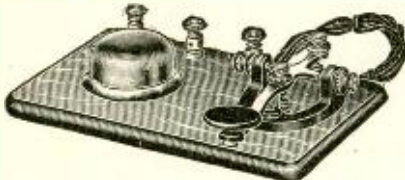

The Practice Set comprises a regular telegraph key without circuit breaker, a special high pitch buzzer, one cell Red Seal Dry Battery, and four feet of green silk covered flexible cord.

The key and buzzer are mounted on a highly finished wood base, and three nickel plated binding posts are so connected that the set may be used for five different purposes.

List No. 342, Telegraph Practice Set, with Battery and cord. Price \$3.24
Weights 4 lbs. packed.
Price does not include postage.

MESCO Combination Practice Set for Learning the Mo. and Cont. Visual and Audible Codes



This outfit is the only reliable instrument which will enable students to become proficient operators in the U. S. Naval Service, because it is equipped with a buzzer and miniature lamp enabling the user to master both the visual and audible signals quickly.

List No. 52—Practice Set with Red Seal Battery and Cord. Price \$4.05
Weights 4 lbs. packed. Price does not include postage.

We carry a Large and Complete Line of Standard Wireless Material Recognized by Experts as such with Competent Experienced Wireless Attendants in Charge.

Send for the New Edition of Our Catalog W28

It is pocket size, contains 264 pages, with over 1,000 illustrations, and describes in plain, clear language all about Bells, Push Buttons, Batteries, Telephone and Wireless Telegraph Material, Electric Toys, Burglar and Fire Alarm Contrivances, Electric Call Bells, Electric Alarm Clocks, Medical Batteries, Motor Boat Horns, Electrically Heated Apparatus, Battery Connectors, Switches, Battery Gauges, Wireless Telegraph Instruments, Ignition Supplies, etc.

Manhattan Electrical Supply Co., Inc.
17 Park Place, New York, N. Y.
CHICAGO 114 S. Wells St. ST. LOUIS 1106 Pine St.
SAN FRANCISCO OFFICE: 604 Mission St.

The Mt. Wilson 100-Inch Reflecting Telescope

(Continued from page 942)

drafts this floor is surrounded with a metal wall 9 feet high.

MOVING PARTS WEIGH 100 TONS.

The telescope tube is 11 feet in diameter and consists of 4 sections. The moving parts of the telescope weigh 100 tons and this immense mass is supported by a unique system of mercury flotation. Two cylindrical pedestals rest in cast iron tanks with 1/8 inch clearance between pedestal and tank which is filled with mercury. A plunger device adjusts the mercury to any desired level. For driving this huge mechanism the lower end of the polar axis carries a worm wheel having 1,440 teeth cut with the utmost accuracy and meshing with the driving train of the clock.

The driving clock, a marvel of scientific accuracy and mechanical perfection, is 6 feet high and covers a floor space of 5 1/2 feet by 4 feet. The clock is operated by a weight of 1 1/2 tons whose falling is governed by a pendulum. Every 12 minutes the clock is automatically wound.

The telescope and dome are operated from a desk at the 42-foot level by means of a system of electric controls. Without leaving his chair the observer may point his telescope to any portion of the heavens and rotate the dome and platform at will. In all there are 40 electric motors ranging from 1/20 to 7 1/2 horsepower and making a total of 50 horsepower with 13 miles of wiring.

To prevent temperature changes an insulating chamber with walls of cork one inch thick is built about the mirror cell. In addition fans circulate the air about the mirror and keep its temperature even.

The telescope carries photographic attachments and a spectrograph of great refinement. Much of its work will be done by aid of these instruments.

At last when both mirror and mounting were complete came the very delicate task of transporting to the top of the mountain the precious disc of glass, without which all these years of patient toil and outpouring of genius would be in vain. It was a Herculean undertaking. Most carefully the glass was lifted from the grinding table and lowered into an octagonal box lined with paraffin paper. Inside the paper carded wool and Brussels carpet were packed to lessen the danger from shock and heat. The cover of the box was likewise padded with carpet and wool and securely fastened in place. The box itself was wrapt in paraffin paper clamped between heavy timbers and provided with a ring for lifting. The motor car which transported it was lined with cushions in which were strong springs, and heavy timbers were bolted to the bed of the car. Then the ascent began and as all the world knows it was crowned with success.

HOW A CONCAVE MIRROR PRODUCES AN IMAGE.

To understand the operation of a reflecting telescope it is necessary to know how a concave mirror produces an image. Unlike a plane mirror the reflected rays of light actually come to focus at some distance in front of the mirror and produce a real image. A real image may be caught on a screen and it is not upright, as that of a plane mirror, but inverted. The production of such an image is shown in the accompanying figure. A line drawn to the middle point of the mirror and perpendicular to it is called the principal axis. Now all rays of light coming to the mirror parallel to the principal axis will

(Continued on page 946)

The Livest Catalog in America

Our big, new electrical cyclopedia No. 21 is waiting for you. Positively the most complete Wireless and electrical catalog in print today. 180 Big Pages, 500 illustrations, 300 instruments and apparatus, etc. Big "Treatise on Wireless Telegraphy." 20 FREE coupons for our 160-page Wireless Course in 20 lessons, FREE Cyclopedic No. 21 measures 7x5 1/2". Weight 1/2 lb. Beautiful stiff covers.

Send 6 cents in stamps or coin for which we will send our latest Cyclopedia Catalog No. 21 as described.

ELECTRO IMPORTING COMPANY
231 Fulton St., New York City

20,000 Meter Long Wave Tuner 3,000 Meter Arlington Tuner 200 Meter Amateur Tuner

They work on any aerial or loop. Wiring diagrams on bottom. Coils machine wound and set in wax. No delicate tuning. Foreign orders solicited. Catalog free. Agents and dealers wanted. Price \$15 delivered to you.



TRESCO, Davenport, Iowa

Universal Radio System

Up to the minute radio apparatus for progressive users who can recognize quality. Send stamp for catalogue.

Universal Radio Mfg. Corp.
Dept. W Elmira, N. Y.

WILCOX PANEL SWITCH

"The Best"
1/2 In. Radius Postpaid Price
Complete Switch, polished brass finish. 50c
Complete Switch, nickel plated finish. 25c
Knob, turned and polished. 25c
Switch points, brass finish. 2c
Switch points, nickel plated finish. 2c

THE WILCOX LABORATORIES, Lansing, Mich.

WIRELESS Apparatus, Raw Materials, Magnet wires,

motors, experimenters' needs, novelties listed in our Catalogue C-3. Assure yourself of prompt service and right prices by buying from this world famed, reliable, Experimenters' Supply House. 99 of every hundred orders received shipped within 24 hours. Catalogue C-3 FREE on request.

THE NEWMAN-STERN CO., Cleveland, O.

Arnold Loose Couplers

Combination Loose Coupler Parts and accessories. Send 3c stamp for literature which is sure to interest you.

J. F. ARNOLD 2082 Lexington Av. N.Y. Established 1910

RECO QUALITY SUPERLATIVE RADIO EQUIPMENT

THE BEST KEY IN THE COUNTRY
10 Amp. \$7.75—20 Amp. \$8.25
A three cent stamp will bring bulletins of this and other higher grade apparatus.

THE RADIO ENGINEERING COMPANY,
22 St. Paul St., Baltimore, Md.

SEND TO-DAY For Catalog for Complete Line of Receiving Apparatus

REMLER RADIO MFG. CO.
163 Sutter St. San Francisco, Calif.

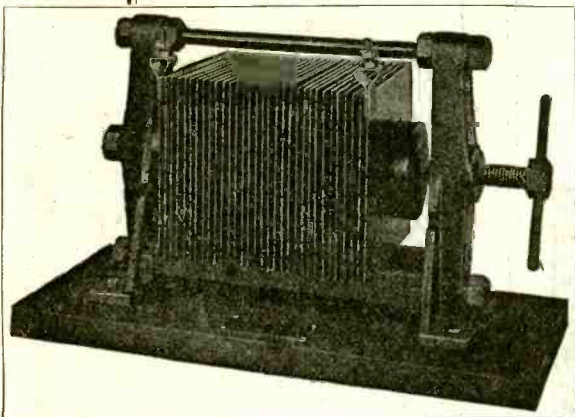

A 240 Spark Note on 60 Cycles

with three to four times the energy in your antenna and with a low decrement entirely inside government regulations—all possible with the

“AMRAD” QUENCHED GAP

\$17.50

Folder giving complete specifications sent on request.

Our bulletin No. 12 sent on request tells how

Altho within the reach of every amateur's means, this GAP is on par in performance with the finest commercial quenched gap. Not only does it increase the efficiency of your station three to four times, but is economical to use because it can be operated without a motor, which effects a saving in current.

Ask your dealer today to show you the AMRAD Quenched Gap. If he does not have it, order direct from us but send us his name



Keep out of trouble

You can measure your wave length with absolute accuracy and no difficulty with the

“AMRAD” WAVE METER \$5.

In this very simple and reliable device a flashlight bulb and direct reading dial give instantaneous and precise measurement of your transmitting wave. It entirely eliminates danger of violating government rules.

*Your dealer can supply you
Descriptive folder sent on request.*

Makes DC like AC

For the amateur who operates where AC is not available the

“AMRAD” INDUCTION COIL \$28.50

Works as consistently as a transformer

Adapted for amateur use from the designs for the army signal corps coil, the AMRAD induction coil entirely overcomes difficulties found in all other coils.

A special model is made for use with 32 volt farm lighting outfits.

Ask your dealer to show you the AMRAD induction coil.

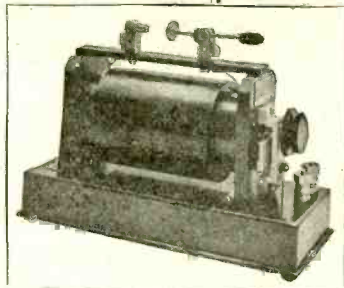

Folder giving complete details mailed on request

AMERICAN RADIO AND RESEARCH CORPORATION

21 PARK ROW, NEW YORK, N. Y.

Laboratory and Works, Medford Hillside, Mass.



"RW4," Size 12" x 9" x 6 1/2"

MIGNON "RW4" UNDAMPED WAVE RECEPTORS

NO Loose Couplers
Loading Coils
Variometers
Amplifiers

Strongest, Most Distinct Signals

IMPORTANT—NOTICE

Ernest C. Mignon, inventor of the famous disc-core undamped wave receptor, is no longer connected with the Mignon Wireless Corporation, of Elmira, N. Y., or their successors—the Universal Radio Mfg. Corp. Address all communications for Mignon apparatus to

MIGNON MANUFACTURING CORPORATION, Newark, N. J.

DAMPED AND UNDAMPED WAVE APPARATUS FOR ALL PURPOSES

Endorsed by Radio Department of D., L. & W.
R. R. Co.

Write for Literature.

MIGNON. MFG. CORP.
NEWARK, N. J.



DUCK'S New Big-264 Page No. 13 Wireless and Electrical Catalog

It will be mailed for 12c in stamps or coin which may be deducted on first order of \$1.00. Catalog not sent otherwise. We regard this catalog as our greatest effort. It embraces everything in wireless worth while. 172 pages with no waste space devoted exclusively to wireless instruments. Your amateur friend will tell you that there never has been any wireless catalog

to take the place of catalog of this company and above all that you can absolutely depend on our goods. There is no need for any other catalog when you have this big catalog.

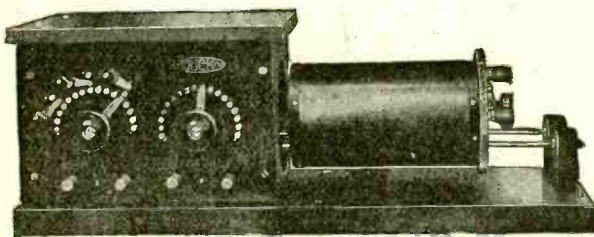

NEW MODEL 5BB. NAVY TYPE RECEIVING TRANSFORMER

A big improvement over our former model. Primary divided into four sections, with three dead end switches, greatly improving selectivity.

Secondary divided into three sections, with two dead end switches, eliminating harmonics. The change in the construction of the guide rod support makes it possible to obtain a looser coupling. It is a wonderful improvement over our old model both in performance and appearance. Only \$23.50.

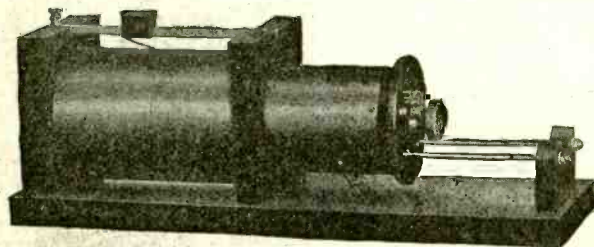

OUR IMPROVED ARLINGTON RECEIVING TRANSFORMER

The secondary on our new type Arlington is divided into three sections with two dead end switches eliminating dead end effect and harmonics and giving greater selectivity. The end support is similar to that on our Navy type permitting a looser coupling. It is a beautifully finished instrument.

Price only \$10.50.

THE WILLIAM B. DUCK CO., 230-232 Superior St., Toledo, Ohio

The Mt. Wilson 100-inch Reflecting Telescope

(Continued from page 946)

as a Newtonian or Cassegrain telescope, but it is in the latter form that it will be most frequently employed. As already stated two convex mirrors have been ground for use in this combination. For putting these mirrors into position a special crane is provided.

The actual mounting of the telescope on its axes follows the English type and is somewhat unusual in this country. In any telescope there are two axes—the polar axis and the declination axis. By rotating the telescope on these two axes it may be turned to any point of the heavens. The polar axis, as shown in the figure, consists of a heavy rectangular yoke parallel to the earth's axis and supported by two pedestals, the north one bearing 40 tons and the south one 60 tons. At the top of these pedestals are the cylindrical tanks and the mercury system of flotation. Mounted on trunions inside this yoke is the telescope tube. The trunions constitute the declination axis and this is at right angles to the polar axis. By rotating the telescope tube about these two axes any heavenly body desired may be brought into view. When this has been done, the large toothed-wheel at the lower end of the polar axis is thrown into gear with the driving mechanism of the clock and the object may be kept constantly in the field as long as the observer cares to look. Stars of course rise and set, just as the sun does, and since the clock turns on the polar axis of the telescope at the same rate that the earth rotates, this must just compensate for the apparent motion of the star. The dome is also made to rotate at the same speed. The observing floor, too, may be raised and lowered to any level with the changing position of the telescope.

MT. WILSON'S SOLAR OBSERVATORY.

The Solar Observatory at the summit of Mount Wilson, 6,000 feet above sea level, free from vibration and immerst in the dustless air and cloudless skies of southern California enjoys an unexcelled location. It is possible to photograph the sun 300 days in the year! Very much of its work will be done with the splendid spectroscopic and photographic attachments of the telescope. By means of photography it will reveal countless numbers of hitherto unknown stars. Not more than 5,000 can be counted with the unaided eye. Up to the building of this giant reflector there existed approximately 219,000,000 telescopic stars; but it is now believed that the population of the stellar universe may be increased by at least 100,000,000. With the spectroscope the elements in stars so remote that the light making known their presence left their surfaces 1,000 years and more ago, may be known with as much certainty as tho they were analyzed in a terrestrial laboratory. Furthermore the spectroscope will reveal the physical constitution of the stars, nebulae and comets. Their motion, too, is disclosed and it can be told whether a star is moving toward us or away from us and with what velocity.

HARVARD DISCOVERS NEW STAR

Another star has been discovered by the Harvard College Observatory. It was announced on January 8th that Miss Joanna C. S. Mackie of the observatory staff, in the course of her examination of photographs of the milky way taken recently at Cambridge, had detected the new comet. Its position is Right Ascension 18 hours 49 minutes 30 seconds, declination plus 29 degrees 6.3 minutes (1900).

The Radio Compass

By **PIERRE H. BOUCHERON**

(Continued from page 907)

(or magnetic field) the wave will strike both sides of the loop at the same time and an equal amount of energy will be induced in both sides of the loop circuit, either in an upward or a downward direction, de-

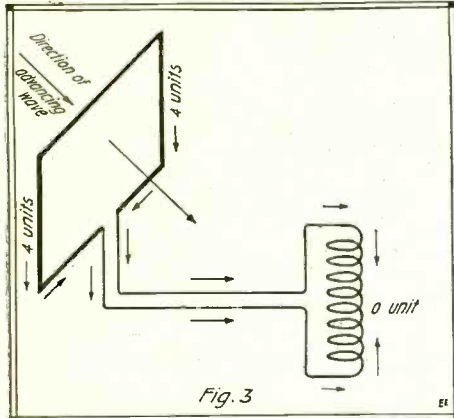

When the Advancing Wave Strikes Both Sides of the Loop Antenna Simultaneously, the Resultant Current in the Receiving Set Is Zero. This Is the Action Employed in Practise.

pending upon which side of the sine wave first strikes the loop windings. Since the currents induced in both sides of the loop are of equal field strength, they will meet and neutralize when the circuit is completed in the receiver, with the result that the detecting apparatus will not respond. Fig. 3 illustrates this action, where the flat front of the advancing wave, having reached the loop and induced currents on each side having an arbitrary current strength of, let us say 4 units, travel to the receiver, reach there simultaneously and neutralize; thereby reducing the current intensity to 0. However, if the loop is swung 90 degrees so that its plane points in the direction of the transmitter, it is evident that the advancing wave, which as explained before is either rising or falling, will strike the front side of the loop either at a higher or at a lower point than the other side, so that the amount of current induced in one side of the loop will be either greater or smaller than the current induced in the opposite side.

The result of all this is that when the two currents meet in the receiver, the stronger will overcome the weaker and the resultant current will actuate the receiver. Fig. 4 illustrates this condition where the advancing wave has induced an arbitrary current intensity of 8 units in the front side of the loop and 6 units in the other side, the resultant being 2 units, which latter is used to actuate the receiver. Of course, in actual practise the difference between the two currents is not very great for the comparatively small loop presents a very small surface to the advancing wave of 600 meters. It will therefore, readily be seen that the farther apart the two sides of the loop are spaced, the greater will be the difference of potential between the two currents, and this difference must be of sufficient intensity to properly respond in the receiver, for that is the one made use of in reading the bearings.

The reason that the minimum current is the one used to read bearings is because there is too broad a variation of the current intensity at the point of maximum, which fact makes it difficult to secure the ideal intensity. On the other hand the current strength variations are very sharply defined at the point of minimum and therefore, a selective reading is more readily obtained. This condition can be better understood by referring to Fig. 5, which is known as the "bilateral" characteristic curve of the loop. The heavy line in the

"ASK ANYONE WHO HAS USED IT"

"My Brandes Headset Never Gives Me a Headache"

(NAME ON REQUEST)

The fitting and lightness are very important. The Brandes Headset excels in these respects. Special attention has been given to this feature.

BRANDES WIRELESS HEADSET

**CLEAR TONE
LIGHT WEIGHT
DEPENDABLE SERVICE**

Score 100% efficiency in actual use. Sharp, Unblurred, Readable Signals assured by

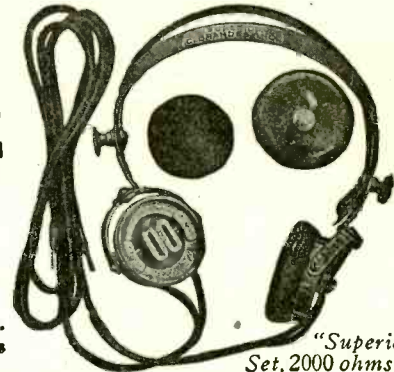

"Superior" Set, 2000 ohms, \$7

"BRANDES MATCHED TONE"

Exactly matching the tone of both receivers in each set and thus eliminating all confusion due to unmatched harmonics.

TRIAL OFFER

Buy a Brandes Superior Headset and use it critically for ten days. Then, if it doesn't come up to our claims or your expectations, return it and your money will be cheerfully refunded. Test it—compare with others—for sensitiveness, clearness, distance. Prove for yourself the fine quality, the "matched tone." The two diaphragms toned exactly alike, strengthen the signals and prevent blurring. Used by many U. S. Government experts, and experts abroad; by colleges and technical schools; and by professionals and amateurs everywhere.

SEND 4c FOR CATALOGUE E.

C. BRANDES, Inc.
Room 814

32 Union Square
New York City, U. S. A.

WIRELESS RECEIVER SPECIALISTS

Complete Line of Brandes Receivers for those in Canada. Send stamp for Pamphlet "E" Radio Electrical Supply Co., 43 McGill College Avenue, Montreal, P. Q., Can.

TRACO QUALITY RECEIVING TRANSFORMERS

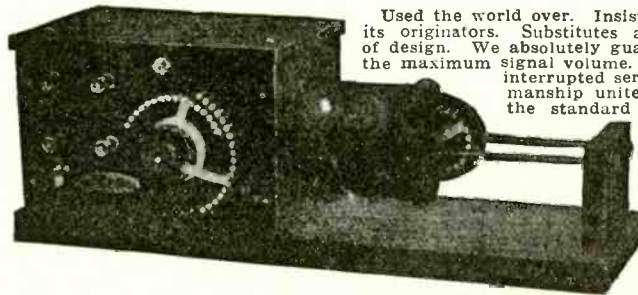

Used the world over. Insist on the genuine, built by its originators. Substitutes are expensive, irrespective of design. We absolutely guarantee our tuners to give the maximum signal volume. Delicate refinement, uninterrupted service and high class workmanship unite to make TRACO tuners the standard whereby all others are judged. If you Dealer does not handle them, order direct from us.

LIBERTY DETECTOR VALVES. RADIO AMPLIFYING PHONES. Type used by the UNITED STATES, BRITISH and FRENCH GOVERNMENTS, now in stock for sale. Send stamps for bulletins.

The Famous 5A and 5C Models

THE RADIO APPARATUS CO.,

Pottstown, Penna., U. S. A.



EASTERN RADIO INSTITUTE

899 Boylston St. Boston - Mass.

TEL. BACK BAY 5964

Learn Wireless

Splendid opportunities now in the Merchant Marine. Big salaries. All graduates GUARANTEED good positions by one of the largest Wireless Telegraph Companies operating hundreds of ships to all parts of the world. REMEMBER: We are the OLDEST, LARGEST and BEST EQUIPPED school of its kind in New England, and have THOUSANDS of satisfied graduates to our credit. THIS SPEAKS FOR ITSELF. Day and Evening classes. Advanced classes in Radio Theory and code. Start any Monday.

Our prospectus for the asking



HAVE YOU A WIRELESS STATION?

Wireless operating is no longer complicated or expensive. You can have your own wireless station completely assembled and be receiving messages within an hour after you get a Gilbert No. 4007 Receiving Set.

This outfit, designed and built by an expert, a Radio Officer in the U. S. Army during the war, is a complete station of the latest and most approved type and will receive messages from stations 300 miles away. The Loose Coupler included is not the old, obsolete type that pulls out of the box but a compact instrument of the new enclosed panel type, in a quartered oak cabinet.

The Book of Instructions included with the outfit contains full information about operating and tells the location of Government and commercial wireless stations—when they send messages and how to receive them.

Gilbert Radio outfits are all illustrated and described in our special Radio catalog—sent free on request. If you wish to purchase a Gilbert outfit immediately and your dealer cannot supply you, write us direct.

The A. C. Gilbert Company
 311 Blatchley Avenue New Haven, Conn.
 In Canada: The A. C. Gilbert-Menzies Company, Limited, Toronto
 In England: The A. C. Gilbert Company, 125 High Holborn, London, W. C. 1.



4007 SET

Make Your Own WIRELESS APPARATUS



SAVE 1/2

It's easy to make your own at home with the aid of these 4 up-to-date books that you can understand. Each has over 72 pages and over 60 illustrations, 3 color cover, size 5 x 7 inches.

LESSONS IN WIRELESS TELEGRAPHY is a course in the elementary principles which you must understand to obtain good results.

WIRELESS CONSTRUCTION AND INSTALLATION FOR BEGINNERS gives complete details with working drawings for making simple but good sending and receiving apparatus and erecting aerials, etc.

THE OPERATION OF WIRELESS TELEGRAPH APPARATUS shows how to obtain best results and greatest ranges with all kinds of apparatus, how to tune the station to 200 meters, use a wave meter, apply for license, etc.

EXPERIMENTAL WIRELESS CONSTRUCTION gives details, with working drawings for making more elaborate and efficient sending and receiving apparatus, complete sets, etc.

30c Each Postpaid \$1.20 the SET

Less than the price of one telephone receiver. Order now while the supply lasts.
COLE & MORGAN, Inc. Publishers
 Dept. 114, 19 Park Place, New York

FREE We are giving away hundreds of expensive wireless instruments, electrical apparatus, supplies, etc., for selling a household article that goes like wildfire because it is a genuine necessity and because it sells so cheap. All of our premiums are guaranteed new and perfect. We give you no junk. Send us your name and address and we will send you twelve articles prepaid complete information and premium catalogue.
 L. Beck Novelty House, 1298 Carroll St., Brooklyn, N. Y.

center of the two circles represents the loop, which, while at that angle, is receiving the advancing wave at maximum strength where the undesirable broad intensity lies. As the loop is gradually swung, however, from 300 degrees to 270, the wave strength gradually decreases to a sharper degree, until when the loop has reached 180 degrees, the current is practically zero. The reading is therefore secured just before reaching zero intensity and at a point where it is very sharply defined; i. e., at the minimum current strength. This minimum reading, of course, is taken into account on the compass dial and the compass pointer is set accordingly.

The Radio Compass as explained thus far is known as bi-directional; that is, it gives general east-and-west, or north-and-south direction and therefore is subject to an error of 180 degrees. This error is not serious in land radio compass stations as the geographical position of the station always enables the operator to determine the proper direction in respect to sea and land. For instance, if the *Montauk* station gave a bearing of 330 degrees, which points directly inland, the operator would know quite well that the ship's position would be directly opposite, in other words at 150 degrees, as will be evident by studying the scale of the *Montauk* station in Fig. 1. On board ship, however, it is quite another matter and to be effective a radio compass must be uni-directional.

HOW BEARINGS ARE OBTAINED.

Radio compass stations as controlled by the U. S. Navy usually operate in units of three, and sometimes four and five, as in the case of the New York harbor approaches and are operated by remote control; that is, all compasses are connected by telegraph wires to a control center, which supervises the activities of all outlying stations. In the case of New York, this central point is situated in an office

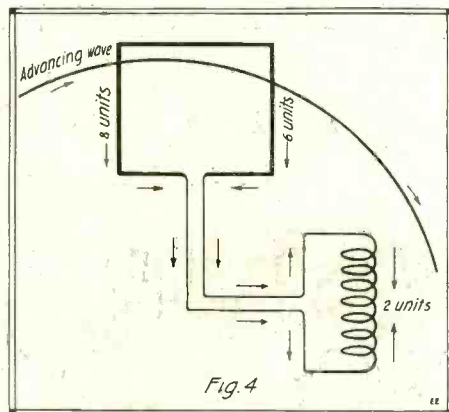

Here the Advancing Wave Strikes the Front and Rear of the Loop at Different Levels and Induces Currents of Different Strengths. Hence the Resultant Current Will have a Measurable Difference of Potential.

building near the Battery, where not only radio compass operation is supervised but all radio traffic as well. The procedure for furnishing or obtaining bearings to or from incoming or outgoing vessels is as follows:

The ship calls "NAH" (call letters of N. Y. Radio) in the regular commercial manner and transmits the special radio compass signal "QTE?" (meaning "what is my true bearing?"). The radio compass supervisor at the control station, by making use of one of the local transmitters, then instructs the ship to "send MO for two minutes"; the signal "MO" being a special one recognized by radio compass stations. After this the supervisor simultaneously informs all outlying compass operators by means of direct telegraph wires controlled by a master key, to secure bearings or directions from which the ship is sending "MO" signals, usually on a wave length of either 600 or 800 meters—800 meters to be used exclusively after April 1, 1920.

Your Future

The demand for Radio operators both at sea and in land positions still persists. Better inducements are constantly offered. Our brief course equips you thoroughly for the best paying positions.

Terms moderate and payments arranged to suit your circumstances.

SCHOLARSHIPS TO EX-SERVICE MEN

Call or write for descriptive literature.

Y. M. C. A. RADIO SCHOOL

Marcy Avenue near Broadway
 Brooklyn

Telephone Williamsburg 3800



The Newest Things IN WIRELESS

Are in These Three Books Just Off The Press

RADIO INSTRUMENTS AND MEASUREMENTS
 Every amateur should have this book as it answers the questions you want to ask and covers all phases of the subject matter indicated by its title.

Cloth Bound, 320 Pages. Price \$1.25
THE WIRELESS EXPERIMENTERS' MANUAL
 By E. E. Bucher

Mr. Bucher's latest book. The only one that comprehensively covers all phases of wireless work, including the latest practices in both Radio Telegraphy and Telephony. Most complete text book on these subjects yet published.

Cloth Bound, Approximately 300 Pages. Price \$1.75
HOW TO CONDUCT A RADIO CLUB
 By E. E. Bucher

One of the most popular wireless books ever published. Covers parliamentary procedure, indoor and outdoor experiments, 5,000-mile receiving sets, use of vacuum tubes and many other subjects.

Paper Cover, 148 Pages. Price 50c
THE WIRELESS AGE

A monthly magazine that will keep you posted on the up-to-the-minute things in wireless communication. Official organ of the National Amateur Wireless Association.

Price Per Year \$2.00

SPECIAL COMBINATION PRICE
 All Four for Only \$4.50

WIRELESS PRESS
 1850 Woolworth Building, New York

A New VACUUM RECTIFIER TUBE for Wireless Telephone

absolutely the newest device on the market. Does away with motor generator. It permits you to use 110 VOLTS 60 CYCLES alternating current and rectifies this to direct current for the transmitting tube.

Get our free descriptive circular 12A

WIRELESS EQUIPMENT CO., INC.
 19 Park Place New York, N. Y.

CATALOG H

Send 5c in stamps for your copy today and get on mailing list for future bulletins without charge. Contains 24 pages of reliable apparatus, standardized parts and raw materials. Complete line switch points, knobs, switches, rod, aerial wire, etc.

SHOTTON RADIO MFG. COMPANY, P. O. Box 3, Scranton, Pa.
 Branch: 8 Kingsbury St., Jamestown, N. J.

When the ship has concluded transmission of the "MO" signal it is then instructed to "QRX" (stand by), after which the supervisor obtains the respective bearings secured by the compass operators; i. e., Mantoloking, N. J., Sandy Hook, N. J., Fire Island, L. I., and Montauk, L. I. All individual bearings are then plotted on a specially prepared chart similar to Fig. 1,

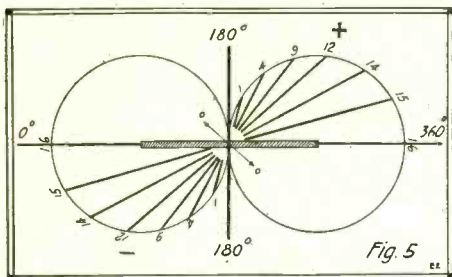

The Current Strength Variations in the Radio Compass are More Sharply Defined at the Point of Minimum and Therefore a More Selective Reading is Obtainable Than if the Maximum Strength of Signal Were Used.

and the resultant position will be the point of intersection of all combined bearings. An example of this is shown in Fig. 1. The bearings are then transmitted to the vessel in the following form: "QTE (your true bearing is) at _____ (whatever time the observation is made) 186 degrees from Montauk; 132 degrees from Fire Island; 112 degrees from Sandy Hook; 96 degrees from Mantoloking (signed) NAH". It is then an easy matter for the navigator of the vessel to plot the bearings on his own chart and thus secure his exact position!

The complete operation from the time of call to the transmission of result is usually accomplished within five minutes. Not only is this information valuable to the navigator but is also made use of extensively by various agencies on land concerned with the movements of naval vessels, transports, revenue cutters, cargo vessels, etc. In the case of incoming passenger vessels, their positions are telephoned to Customs, Post Office, Immigration and Ship News officials in order that steps be taken to meet these vessels at the proper time and make other necessary preparations.

FUTURE OF THE RADIO COMPASS.

The radio compass has come to stay. Every day news comes that one or more stations have been erected at various points of American and foreign coasts. Canadian, French, English and Italian governments have erected radio compasses at important shipping sections and are co-operating with the United States in order to make the service uniform and popular with skippers of merchantmen. In fact, an international radio compass conference will probably be held very shortly where standard wave lengths, methods of furnishing and securing bearings, special abbreviations and other details of procedure will be adopted for international marine use. Masters of vessels are gradually learning of the safety and advantage gained by the use of the radio compass during bad weather or fog, when other means of ascertaining positions are unavailable, and judging from past performances, it is estimated that fully 50,000 requests for assistance will be made by vessels during the coming year. This service is open gratis to any vessel equipped with radio apparatus, no matter of what nationality or tonnage. Modern nautical schools have included the radio compass as part of their curriculum for navigators. Great sums of money are being expended yearly by various governments to develop this new art and make it 100 per cent efficient, and there is no doubt that in a very short time it will be as indispensable a part of the world's merchant marine, as the lighthouse service has been for centuries past.

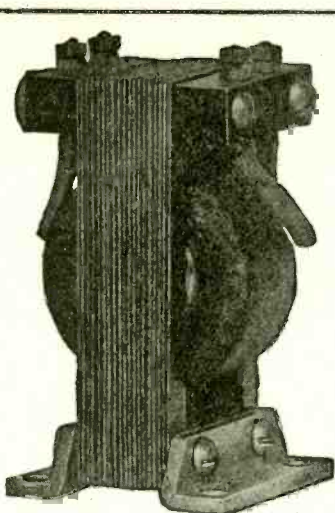

Vacuum Tube Socket
(Type Triode F)

The base of this socket is bakelite dielecto and will not crack and break like the moulded material of the usual socket. Contact springs are stamped with identifying letters. Base is provided with three rubber feet and four countersunk holes for panel mounting.

Price \$1.25 postpaid

AUDIO FREQUENCY TRANSFORMER

Type P

This transformer provides a maximum of low frequency amplification and is superior to all others. It may be used with the Marconi and all standard vacuum tubes.

Permits reliable daylight reception from European stations.

Establishes new amateur long distance records. Renders remarkable amplification of all signals.

Price \$7.00 postpaid

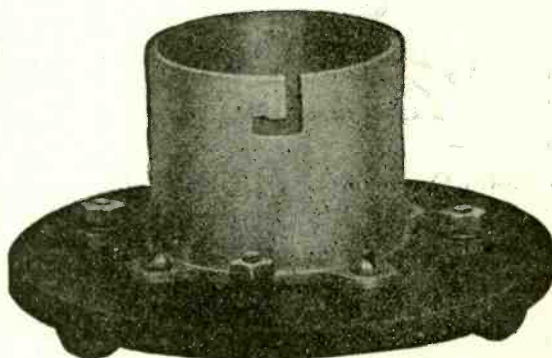

EATON OSCILLATORS TWO STEP AMPLIFIERS
DAMPED AND UNDAMPED RECEIVERS
FARADON MICA TRANSMITTING CONDENSERS

WIRELESS SPECIALTY APPARATUS CO.

ENGINEERS, DESIGNERS, MANUFACTURERS

Boston, Mass., U. S. A.

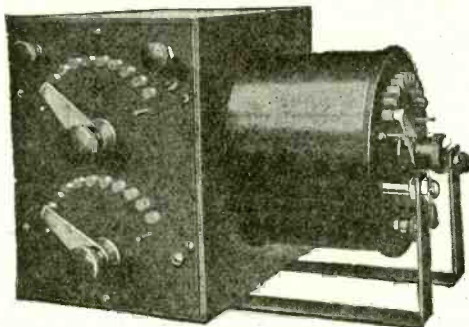

Type-Y673-Coupler

TYPE Y673 Coupler
200 to 3000 meters
Price \$14.00

Camb. Rectifier, for storage battery charging
Price \$22.00

Three-cent stamp brings bulletins of both these instruments

CLAPP EASTHAM CO.

131 Main Street, Cambridge, Mass.

Pacific coast representatives: Remler Radio Mfg. Co., San Francisco
Canadian representatives: Radio & Electric Supply Co., Montreal

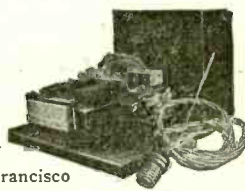

WANTED

1800 Men, 18 to 35, to become Railway Mail Clerks Commence \$1300 a year

Rapid advancement to higher Government Positions. "No lay-offs" because of STRIKES. THE POSITION IS YOURS FOR LIFE. Country residents and city residents stand the same chance. Common-sense education sufficient. Pleasant work, traveling much. Paid vacation. Write immediately for free list of Government positions now open. Don't delay. Every day you lose means the loss of just so much chance of your early appointment.

FRANKLIN INSTITUTE, Dept. N 101, Rochester, N. Y.



FRANKLIN INSTITUTE, DEPT. N 101, ROCHESTER, N. Y.

This coupon, filled out as directed, entitles the sender to free specimen questions; a free copy of our book, "Government Positions and How to Get Them," a list of Government positions now open, and to consideration for Free Coaching for the position here checked.

COUPON

- .. Railway Mail Clerk.....(\$1900-\$2000)
- .. Postoffice Clerk.....(\$1200-\$1650)
- .. Postoffice Carrier.....(\$1200-\$1650)
- .. Rural Mail Carrier.....(\$ 920-\$2160)
- .. Bookkeeper.....(\$1100-\$1800)
- .. Customs Positions.....(\$ 900-\$1500)
- .. Internal Revenue.....(\$ 800-\$1800)
- .. Stenographer.....(\$1100-\$1500)
- .. Clerk in the Departments at Washington.....(\$1100-\$1500)

Name

Address

Use this before you lose it. Write plainly.

MURDOCK No. 55



2000 Ohm Set. \$4.50
 3000 Ohm Set. 5.50

WHY PAY MORE?

Here are receivers that will respond to the feeblest signals. They are unquestionably

SENSITIVE

Here are receivers so rugged in construction that they will keep their sensitive adjustment longer than any others made. They are unquestionably

DURABLE

Here are receivers fitted with every accessory tending to comfort and convenience. They are unquestionably

COMFORTABLE

Here are receivers designed to have 100% perfect appearance. They are unquestionably

GOOD LOOKING

They fill every requirement in every respect, at prices considerably under any obtainable anywhere.

WHY PAY MORE?

The demand for our receivers and other MURDOCK apparatus has been so great that we advise early orders if you wish to secure prompt service.

Bulletin 19B sent free on request

WM. J. MURDOCK CO.

55 Carter Street, Chelsea, Mass.
 509 Mission Street, San Francisco

WIRELESS AMATEURS

Send a 2c. stamp for full description of

The Barr Mercury-Cup Detector

the most efficient detector in the wireless field today.

Tested by Marconi Wireless Telegraph Co. and U. S. Government.

Increases the efficiency of every wireless receiving set by making the signals clear, sharp and distinct. Instantly adjustable at a constant pressure.

THE BARR MERCURY-CUP DETECTOR

Dept. A, The Wyoming, Washington, D. C.

The Electrical Machinist

By H. WINFIELD SECOR

(Continued from page 903)

ture core are good and tight on the shaft, so that some of them will not move when being turned or filed and thus cut into the winding and short-circuit it, "the operation is usually successful," as the doctor would say.

REBABBITTING OF WORN BEARINGS.

The usual practise in repair shop work and also in the manufacture of some motors and dynamos is to babbitt the bearings. Babbitt metal is a mixture of several metals in the following proportions:—Tin—50 parts; copper—1 part; antimony—5 parts. Phosphor bronze contains:—Copper—79.17; tin—10.22; lead—9.61, and phosphorus—.94. A mixture for an anti-friction metal is:—Lead—88.32; antimony—11.93.

The pouring temperature of the molten babbitt metal should not be allowed to exceed 470° Centigrade. The simplest shop test to determine when the babbitt metal is hot enough for pouring, is to stick a piece of paper or a splint of wood into the babbitt metal for a second, and if it bursts into flame, the metal is at the correct temperature for pouring. For first class work of course, some form of electrical or other regulator is necessary to keep the temperature of the molten babbitt metal at an even degree or between the limits of 460 to 470° Centigrade. The metal should be stirred thoroly by means of a ladle at frequent intervals, or otherwise the heavy metals will settle at the bottom of the pot, also the skum which gathers at the top of the molten metal should be removed from time to time and to prevent oxidation the molten metal should be kept covered with a light layer of charcoal or grafit.

One of the accompanying illustrations shows a clever self-skimming ladle which is provided with inside bridges which pre-determine the size of the metal stream in pouring, and for preventing skum from the top of the ladle getting into the bearing. Leather holders to protect the hands in holding the ladle are shown at the right of the figure. In pouring babbitt metal into the bearing, the bearing being invariably stood upright for the purpose, as shown in Fig. 3, you should pour from the ladle in a steady stream, directly down along the mandrel or shaft, to avoid splashing or pocketing of air. The lip of the ladle should be kept free from burrs or other surface irregularities in order to pour a smooth, round stream. If the hot metal is splashed against the shaft, it will cause blow-holes and give a "mushy" bearing.

Referring to Fig. 3-A, this shows a common type of bearing in which the inner lining is formed solely of babbitt metal. If such a bearing has to be relined with this metal, it is placed in a gas stove flame or that from a gas blowpipe, until all the old babbitt metal is melted out. It should be thoroly cleaned and scraped inside and several small holes are drilled thru the brass shell, as at C, into which some of the molten metal will run and help to lock the new babbitt lining into place. Over these openings a piece of asbestos can be tied tightly and into the set screw and oil holes at the top and bottom a piece of wood can be tightly threaded. The bearing is then usually set upright on a piece of asbestos and packed around with wet fire clay or putty, as shown at Fig. 3-A. For small bearings that is all that's necessary, and no shaft or mandrel is placed in the center; when the newly poured bearing is cooled, it is then "chucked" in the lathe and bored

RADIO OPERATORS

\$125.00 per month and upward plus all expenses.

Modern Equipment—
 Special Short Course
 Individual Instruction
 Finest Staff of teachers available

Dormitory—Swimming Pool

Call or write for illustrated booklet

Y. M. C. A. Radio School

Dept. R.

152 E. 86th Street New York, N. Y.

"BEST RADIO SCHOOL IN THE EAST"

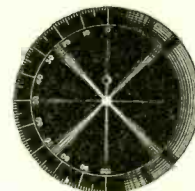

3-INCH DIAL INDICATOR

Black Composition with Brilliant White Filled Engraving

Dial No. 66 only postpaid \$.75

Dial No. 67 with Bakelite Knob, postpaid, \$1.30.

For Sale By All RADISCO Agencies and by

A. H. CORWIN & CO.

4 West Park St., Newark, N. J.

MARKO STORAGE BATTERIES

ARE GOOD—TRY ONE

Paul M. Marko & Co., Inc.

1402-1412 Atlantic Ave. Brooklyn, N. Y.

SELENIUM CELLS

Made by entirely new process. Highly sensitive and quick-acting. Suitable for all experiments. From \$5 up.

Write for Catalog

Selenium Laboratories

Good Ground, Long Island, N. Y.

FREE Our catalog covering a complete line of Bargain "Better Quality" Wireless Apparatus. *Send today—Do not hesitate.*

The H. S. Wireless Co.

164 Ross Street Brooklyn, N. Y.

[Be FREE From STAMMERING

Home Exercise Course. Results GUARANTEED or NO PAY. Write for full particulars. Sutherland Course, Educational Bldg., 70-5th Ave., N. Y.



158 Genuine Foreign Stamps—Mexico War Issues, Venezuela, Salvador and India 10 Service, Guatemala, China, etc. Only Finest Approval Sheets 50% to 60%. AGENTS WANTED. Big 72-p. Lists Free. We Buy Stamps. Established 25 yrs. Hussman Stamp Co., Dept. 67, St. Louis, Mo.

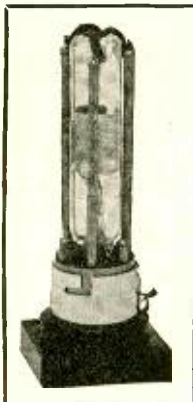

**The ORIGINAL
AUDIOTRON
ADAPTOR**

\$1.75 Each
Shipping Weight One Pound

Your Tubular Bulb will now fit the standard "VT" socket with our adaptor

**New Type "VT" Socket
Now \$1.00 Each**

Our adaptor consists of a standard base with nicked brass pillars appropriately placed to accommodate five leads and support tube. Pillars are forced into solid bakelite, not sealing wax.

We have PARAGON back-mounted rheostats, \$1.75
New radio call book out Jan. 15, '20, \$1.00 each
RADIO EQUIPMENT CO.
630 WASHINGTON ST. BOSTON, MASS.

**The "ACE"
Vacuum Tube Socket**

Designed to fit the Standard four prong vacuum tube. The top part is a finished aluminum casting mounted on a formica base one-quarter inch thick. This base will not break under any condition of service, as moulded composition bases will. Heavy phosphor-bronze springs are mounted on the under side of the base for connection to the tube prongs. This is the only vacuum tube socket on the market which has the grid leak built in as part of the socket. It may be used for back or front of panel mounting. The best socket on the market regardless of price.

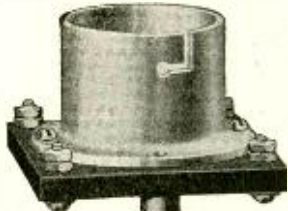

**\$1.50 each
complete
with grid
leak**

We manufacture a complete line of Radio apparatus.

THE PRECISION EQUIPMENT CO., INC.
Manufacturing Engineers
2437 Gilbert Ave. Cincinnati, Ohio
Dept. E

**AMERICAN ELECTRO
TECHNICAL APPLIANCE CO.**
235 Fulton Street New York City

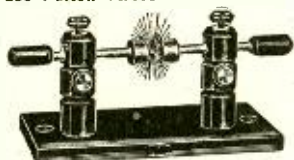

Spark Gap, \$1.10



Switch Points, 18c per Doz.

All Parts for the Amateur to Build His Own Sets, Complete Coupler, Parts, Tuners, Cabinet Sets to Build, Etc.

DE FOREST'S APPARATUS ALWAYS ON HAND

Radio Amateurs Wanted

to represent us in your town and vicinity. Work consists of calling upon our prospective students and telling them about the N. B. I. Ten Weeks Home Study Wireless Course. Liberal commissions allowed. We furnish names and addresses to call upon—and printed matter for free distribution. Write at once for exclusive rights in your section. National Radio Institute, Dept. 162, 14th & You Sts., Washington, D. C.

WIRELESS

On account of increased demand for Radio Operators, we have concluded to give a correspondence course aside from our regular day and night classes. Write for rates. FREE learning instruments.

Write for Literature, **SOUTHERN WIRELESS INSTITUTE**, 22 St. Paul St., Baltimore, Maryland.

ADVERTISING PAYS

It pays the man who advertises and it pays the man who answers ads. For advertising rates in the E. E. address **Advertising Dept., 233 Fulton St., N. Y.**

and reamed out to fit the shaft. When a bearing is of good size, however, two methods of procedure are followed:

In an emergency, as for instance where the bearing is sometimes to be rebabbitted right on the machine, without removing the shaft or housing, the molten babbitt metal is poured into the properly prepared bearing housing and allowed to cool against the shaft, which is to turn in it, without giving excessive play when it is cooled. Where a first class bearing is desired, with regard to a close fit, so that the shaft just turns freely in it when it is finished, the procedure is then to use a mandrel slightly smaller than the shaft, and this is accurately placed in the center of the bearing. When the molten babbitt metal is poured in there will be a hole thus left in the center of the bearing, somewhat smaller than the proper size to fit the journal which is to run in it. The bearing is then placed in the lathe, carefully centered as regards the outside supporting surface of the bearing, drilled or bored out with a boring tool to nearly the required diameter, and then if a first class finish is desired, reamed out with the proper size reamer.

Fig. 3-B shows a bearing set up ready for pouring, and in which there has to be secured by the babbitt metal filling, a bearing sleeve which is often of phosphor bronze, brass, steel, or even iron pipe. This sleeve is held accurately in place by means of a shaft or mandrel carefully centered and held by jigs or clamps, together with the bearing, onto the base plate of asbestos or else a metal plate on which rests a piece of asbestos. In this case the sleeve should have its outer surface, which is to be in contact with the babbitt metal, thoroly tinned, and it should also be heated before being placed into the bearing ready for pouring. One clever make of electric motor utilizes a cast iron sleeve for a bearing, which the manufacturers claim they have found very satisfactory for cool running and even wear.

The Westinghouse concern recommends the following procedure for bronze, pipe, or steel shells (tinned):—"Remove the old lining by heating, preferably in a pot of scrap babbitt, and be sure not to heat above 375° Centigrade. Just as soon as the old lining is melted out, swab the tinned surface with zinc chlorid (a saturated solution of zinc in hydrochloric acid), then dip into a pot of "half and half" solder, which should be kept at a temperature not less than 340° C. and not more than 375° C. If shells are to be babbitted immediately, do not touch tinned surface after removing from the solder pot. If the shells are to be allowed to cool, brush off the tinned surfaces with a piece of clean waste."

GROOVING REBABBITTED BEARINGS.

Fig. 4 shows how oil glands or grooves are tooled in babbitted bearings and also one form of hand grooving tool. The grooving tool is made of tool steel forged out to the shape shown, either from square, round or hexagon stock, and it is usually curved slightly upward along the length of the tool. For small bearings the tool is about five inches long, while for large bearings the tool is sometimes provided with or else forged onto a long, low grade piece of steel one foot or more in length. The bottom edge of the tool is rounded to a semi-circle and the sides taper towards the top so as to give the appearance as shown in tool drawing at Fig. 4. The grooves in small bearings are cut to semi-circular shape from the oil ring slots, so that the oil as it falls on the shaft from the revolving oil rings or oil chains, will be spread

**Your Choice
50c a Week**



FREE!

With every set is included—**FREE**—a Consulting Membership which gives you the privilege of submitting your perplexing problems to a corps of experts for an entire year. This Consulting Membership regularly sells for \$12.00.

No matter what your occupation, one of the home study sets listed below will quickly fit you for a better job and bigger pay. Any set you select will be sent for seven days' examination, and if you decide to buy you may pay the rock-bottom price at the rate of only 50c a week. But you must act now! The rising cost of paper and binding materials won't permit us to continue the present low prices much longer.

These books are the work of recognized authorities. They are written in plain, easily understood language by recognized authorities, and contain hundreds of photographs, diagrams, tables, etc., that make difficult points as simple as A-B-C. Handsomely and durably bound in half or full morocco leather (except as noted), and stamped in gold.

**Pay-Raising Books
at Greatly Reduced Prices**

- Carpentry and Contracting**, 5 volumes, 2133 pages, 1000 pictures. Was \$25.00.....Now \$19.80
- Civil Engineering**, 9 volumes, 3900 pages, 3000 pictures. Was \$45.00.....Now 29.80
- Fire Prevention and Insurance**, 4 volumes, 1500 pages, 600 pictures. Was \$20.00.....Now 15.80
- Electrical Engineering**, 8 volumes, 3800 pages, 2600 pictures. Was \$35.00.....Now 24.80
- Automobile Engineering**, 6 volumes, 2600 pages, 2000 pictures. Was \$30.00.....Now 19.80
- Machine Shop Practice**, 6 volumes, 2300 pages, 2500 pictures. Was \$30.00.....Now 19.80
- Steam and Gas Engineering**, 7 volumes, 3300 pages, 2500 pictures. Was \$35.00.....Now 21.80
- Law and Practice (with reading course)**, 13 volumes, 6000 pages, illustrated. Was \$72.00.....Now 44.80
- Telephony and Telegraphy**, 4 volumes, 1728 pages, 2000 pictures. Was \$20.00.....Now 14.80
- Sanitation, Heating and Ventilation**, 4 volumes, 1454 pages, 1400 pictures. Was \$20.00.....Now 14.80
- Practical Accounting**, 4 volumes, 1840 pages, 800 pictures, etc. Was \$20.00.....Now 14.80
- Drawing**, 4 volumes, 1578 pages, 1000 pictures, blue prints, etc. Was \$20.00.....Now 14.80

**Send No Money
Shipped for 7 Days' Trial**

Yes, we'll gladly ship any set right to your home or office upon your simple request. Pay only shipping charges when the books arrive. Don't send a penny until after you have used them seven days, then remit only \$2.00 or return them at our expense. Pay balance at the rate of \$2.00 a month—50c a week.

Act now—while these splendid books are being offered at 20% to 50% less than regular prices. This offer is open to every person within the boundaries of the U. S. and Canada. Grasp your opportunity—fill in and mail the coupon now!

American Technical Society, Dept. X251, Chicago

American Technical Society, Dept. X251, Chicago, U.S.A.

Please send me set of.....

for 7 DAYS' examination, shipping charges collect. I will examine the books thoroughly and, if satisfied, will send \$2 within 7 days and \$2 each month until I have paid the special price of..... If I decide not to keep the books, I will notify you at once and hold them subject to your order. Title not to pass to me until the set is fully paid for.

Name.....

Address.....

Reference.....



Is Your Transmitter Really Tuned?

You may think it is but you don't know unless your station is equipped with a reliable Antenna Ammeter. These Roller-Smith Hot-Wire Ammeters were made for the U. S. Army Air Service for use on fighting planes.

Regularly \$13—Our Special Price, \$7

With the Armistice came a cancellation of contracts and these Ammeters, which had successfully passed the exacting Government tests, were returned to the manufacturers. Each is in perfect condition, packed in its original carton and ready for immediate shipment.

The scale reading is: 0-2.5 Amperes. Shunt giving double or triple this range, 75c extra.

By buying the entire surplus we are able to sell these Ammeters at less than the Government paid for them in lots of one thousand. Better order one today as they are going fast. Remit by check or money order.

A. H. GREBE & CO., 70 Van Wyck Blvd., Richmond Hill, N. Y.

"THERE'S MONEY IN IT!"

AT HOME LEARN TELEGRAPHY AT HOME

MORSE AND WIRELESS

TEACH YOURSELF



In half the usual time, at trifling cost, with the wonderful Automatic Transmitter, **THE OMNIGRAPH**. Sends unlimited Morse or Continental messages, at any speed, just as an expert operator would.

Adopted by U. S. Gov't. 4 styles. Catalogue free.

OMNIGRAPH MFG. CO.
39L Cortlandt St. New York

BOYS, Our Radio Transformers Are the Goods

The only drawback they have is the fact that we have not yet developed a condenser to hold the 1 KW size, and amateurs who have installed this transformer have had trouble, from breaking down their condensers.

We hope soon to announce that a condenser has been developed to hold this transformer.

Send for our new bulletin.

THE ACME APPARATUS CO., - - CAMBRIDGE, MASS.

Wireless Amateurs, Dealers and Manufacturers!

Have You Seen the

"DEPENDABLE"

Line of Radio Instruments and Complete Sets?

We manufacture a large line of **DEPENDABLE** apparatus—not the cheap mail order variety, yet our prices are low. Tuners, Couplers, Detectors, Fixed and Variable Condensers, Loading Coils, etc., also Binding Posts, Switch Points, Switch Levers, etc., etc.

Send for New Catalog No. 9

To our New York Office, 19 Park Place, New York City

DORON BROS. ELECTRICAL CO. Hamilton, Ohio

LEARN WIRELESS TELEGRAPHY

Fascinating and Educational Work—Big Salaries—Prepare Now

The United States Shipping Board is making heavy demands upon us for **Dodge-trained** wireless operators. Travel all over the world, secure, free, unsurpassed living accommodations and earn a big salary.

We Also Teach Morse (Wire) Telegraphy and Railway Accounting

School established 45 years. Endorsed by wireless, railway and telegraph officials. Low rates. Students can earn living expenses while attending school. **Catalog Free. Write Today.**

Dodge's Telegraph and Wireless Institute

26th St.,

Valparaiso, Indiana

along the shaft by means of these grooves or glands. The position of the oil rings or chains are shown at Fig. 4, and when the shaft is placed in the bearing and slowly turned, the rings should rest on it and be revolved by it. They dip into the oil in the lower part of the bearing housing in the manner shown, and keep a continuous supply of oil on the shaft. Any superfluous oil runs out of the ends of the bearings and drops back into the oil well below.

At the right of Fig. 4 is shown a more elaborate *tree design* of grooving in a babbitt bearing from a single oil ring slot. These slots are usually cut in the top of the bearing, as becomes evident. These grooves are cut in babbitt metal bearings and sometimes in bronze or other bearings by means of a tool of the shape shown and described, hitting the tool lightly with a hammer and taking pains to keep the groove of approximately even depth. It takes quite a little practise to make a good job of the grooving but the experience, once gained, is always valuable.

(To be continued)

An Oscillion Radio

TELEPHONE AND TELEGRAPH

(Continued from page 908)

The latter instrument switches from the oscillating circuit to the rectifier circuit, so that the filaments of the tubes in either circuit may be adjusted to the proper current values.

Receptacles for the four oscillating tubes are located directly below the microphone. These receptacles take the de Forest VT Audion bulb which is provided with a four prong base and fits into the receptacle with a bayonet lock. This is a decided advantage since, if a tube burns out it may be instantly replaced without having to make connection to binding posts, etc., by means of flexible leads as in the old fashion. On the right-hand side of the panel below the tubes is located the tuning condenser and receiver. This post represents the aerial receiver connection and the other side of the receiver is connected directly to the ground.

Near the bottom of the panel on the right and left are mounted the filament rheostats. One of these controls the filaments of the four oscillating tubes and the other those of the rectifying tubes at the bottom of the panel. A one ampere scale hot wire ammeter is located to the right at the bottom of the panel for reading the high frequency current output in the aerial circuit. This instrument is connected with the ground lead and there is no danger of a shock should anyone come in contact with it. At the bottom of the panel is located binding posts for connections with 110-volt A.C. circuit, a 6-volt storage battery for the microphone, the key for telegraphing and the ground connection. Connection to the aerial is made by means of a binding post mounted to the right of the panel at the top.

On the back of the panel is mounted the helix, (the inductance of which is variable by means of a contact clip), modulation transformer, tuning condensers filament rheostats, filament switch and condensers. On the base-board in the rear is mounted a special transformer which contains three windings in addition to the input winding which is connected with the alternating current source. One of these windings supplies the high potential for the plate circuit of the oscillator and the other two the low potential filament currents. This set is also supplied to operate on 32 or 110 volts, direct current supply, a dynamotor being furnished.

SELENIUM CELLS

THE

Construction, Care and Use of Selenium Cells with Special Reference to the Fritts Cell

By THOMAS W. BENSON

The lack of definite information relative to the construction of Selenium Cells has led the writer to record the results of some of his experiments and to fully describe the apparatus as developed by him.

CONTENTS OF CHAPTERS

1. Selenium The Element
 2. Consideration of Cell types and their Characteristics; The Bildwell Cell; The Ruhmer Cell; The Mercadier Cell; The Bell and Taintor Cell; The Gripenberg Cell
 3. Construction of Fritts Selenium Cells
 4. Testing and Maturing Selenium Cells
 5. Applications of Selenium Cells
 6. The Care of Selenium Cells
- 73 pages, 15 diagrams and 3 halftone page plates, 7 1/2 x 5 1/4 inches. Cloth.
PRICE \$1.50

SPON & CHAMBERLAIN
120 G Liberty Street, New York

COPPER AERIAL WIRE TWO FEET FOR ONE CENT



We are offering pure copper aerial wire at 50c for 100 feet—No. 14 gauge. Postage and insurance charges must accompany all orders or they will be shipped by express-collect. No C. O. D. orders accepted. Delivery will be made immediately upon receipt of order.

A partial list of a few more of our bargains is printed below.

- Magnets—large and powerful.....\$.30
- Small magnets..... each .20
- Magneto telephones, wall type with powerful 3 bar generator, ringer, induction coil, sensitive transmitter and receiver, made for short and long distance talking, oak cabinet. Room for two dry cells.....each 7.00
- Telephone bi-polar receivers 75 ohm with cords..... .80
- Telephone ringers with bells 600 ohms... 1.00
- Long distance telephone transmitters.... 1.00
- The Famous Skinderviken transmitter button, postpaid..... 1.00

Send for illustrated catalogue, 5c.

ELECTRICAL SPECIALTY CO.—Dept. E
48 So. Front St. Columbus, Ohio



TENOR BANJO \$20

Ukulele, Hawaiian Guitar, Violin, Mandolin, Guitar, Cornet, Tenor Banjo or Banjo absolutely free. Very small charge for lessons only. We guarantee success or no charge. Complete outfit free. Write now. No obligation. SLINGERLAND SCHOOL OF MUSIC, Inc. Dept. 41 - CHICAGO, ILL.

The ROGERS
Violet Ray, High Frequency Generator
Does not burn out. No sparking—therefore all shocks are eliminated. An ideal outfit, fully guaranteed as to material and workmanship.
PRICE COMPLETE \$25.00
With One Surface Applicator
Send for free descriptive Booklet
The Rogers' Electric Laboratories Co.
Dept. B, 2056 E. 4th St., Cleveland, Ohio

The Electrical Engineer at Work

By H. Winfield Secor
(Continued from page 881)

who is invariably a real dyed-in-the-wool engineer-draftsman, has to contend with. The writer has been thru just such work as he now speaks of, and can thus give a clear idea of how this work runs under general conditions. Of course, it all depends on the personnel naturally, and every person works in a slightly different way. For instance, one engineer's sketches from which you may have to work and prepare your initial drawing and layout with the full details on them which you have gleaned during several hours study of a dozen catalogs or so and your ever-ready slide-rule and pocket text-book, may be a very complete and respectable diagram made out on cross-section paper with at least legible figures and letters on them. On the other hand, possibly due to the personal traits of the expert who made these sketches, or perhaps due to his being under great pressure of work, the engineer-draftsman may have to work from sketches which are more or less difficult to understand.

Drafting students, and also engineering students, but particularly the former, should therefore study the fundamentals of engineering calculations and design very thoroly, for they will find that unless they intend to remain as draftsmen, they will have to educate themselves so as to be able to grasp the lower rungs of the engineering ladder, so to speak. As an example, the engineer-draftsman may be called upon to make an initial or preliminary drawing or layout of a new piece of engineering work or apparatus in which he would have to do considerable calculating in order to properly proportionate the various parts. He should be thoroly schooled of course in arithmetic, plane and solid geometry and trigonometry, and he will find it valuable indeed to know something of algebra thru to quadratics. In the designing of dynamos and motors, electromagnets and solenoids, rheostats and various other electrical machinery involving coils or windings, which have to be very carefully designed so as not to heat up unduly, besides many other considerations, the Consulting Engineer or the Chief Engineer will invariably specify the data for all such windings, for it is of course, unreasonable to expect a draftsman, especially a beginner, to know anything about such advanced details of electro-physics. But as the draftsman progresses in his vocation, and after a period of several years, he will in most cases master a sufficient amount of engineering technique and mathematics to come under the general class of engineer-draftsmen, and depending upon how valuable he has made himself in his progression up the ladder, just so much more responsibility and also the greater the remuneration will be accorded him.

THE TRACER'S ROLE IN ENGINEERING

What is a tracer? A tracer in an engineering and drafting room, is either a young man or a young woman (many women having taken up tracing and drafting as well as engineering in the past ten years), and there are two orthodox ways in which tracers start in the engineering profession. The young man secures a position as tracer in a drafting room, and by taking up drawing in night school, soon becomes capable of making drawings.

Tracings are made on either thin transparent paper, or else on tracing cloth which



Be a Draftsman! Make \$30 to \$75 a Week

Your name and address on the coupon brings this great Cyclopaedia of Drawing without a penny down. Pay only net shipping charges when books arrive. With these books and a low price "school set" of drawing instruments, obtainable at any store, a man can become master of drawing and earn \$30 to \$75 weekly. **LEARN AT HOME**—Good paying positions open everywhere. Intense activity in manufacturing, railroading, building, etc., calls for more draftsmen.

Shipped on 7 Days' FREE Trial CYCLOPEDIA OF DRAWING

4 Volumes. 1650 Pages. Thousands of Illustrations. Bound in genuine American morocco. Pages 5 1/4 x 8 1/4 inches. Covers all branches of Drafting—Architecture, Electrical, Structural Steel, Sheet Metal, etc. Teaches pen-and-ink rendering, lettering, free-hand, perspective, shades and shadows, working shop drawings, machine design, etc., etc.

50c a Week—Only \$2 a month if you keep the books. Coupon explains offer, good only within borders of U. S. and Canada. **Free Membership in This Society.**—A Consulting Membership given free with each set—worth \$12.00.



AMERICAN TECHNICAL SOCIETY
Dept. D-251 Chicago

AMERICAN TECHNICAL SOCIETY
Dept. D-251 Chicago, U.S.A.

Please send Cyclopaedia of Drawing for 7 days' examination, shipping charges collect. I will send \$2 within 7 days and \$2 a month until \$14.80 is paid, or notify you and hold books subject to your order. Title not to pass until fully paid.

Name.....
Address.....
Reference.....



Learn to Draw at Home

Illustrators, Cartoonists, Commercial Artists, earn big money, \$25 to \$100 a week and more. Learn at home in spare time under personal direction of Will H. Chandlee, famous newspaper, magazine, advertising artist of 35 years' successful experience.

BE AN ARTIST

Delightful, fascinating profession. Wonderful new home-study method makes drawing easy! Send coupon or postal today for special offer of complete Artist's Outfit FREE to new students. Write for handsome book, "How to Become an Artist." Don't delay—write or send coupon at once. Address

FREE COUPON
WASHINGTON SCHOOL OF ART, Inc.
1470 H St., N. W., Washington, D. C.

Washington School of Art, Inc.
1470 H. St., N. W.
Washington, D. C.



Most Perfect Hearing! THERAPHONE

High Power Scientific Receiver Earpiece is tuned to the ear. It can't confuse nor fatigue. Absorbs shocks, improves the Hearing and conserves time. For Busy, Deaf, Nervous, Privacy and Noises. Guaranteed to suit. (Check or C. O. D.—Export \$2.20.) No Agents. Evolution Phone Company
48 Greenwich Ave., New York City

You Make This FLASHLIGHT BATTERY Yourself
Easily in 3 MINUTES
Then You Know It's FRESH

Serviceable "Make-Ur-Own" Batteries

Instructive—Practical—Useful. Every boy should have one. A Xmas Gift that any friend would more than appreciate.

Make Flashlight Batteries Know They Are Fresh!

Do it Yourself and see the mystic charm of making your own light. Have fun doing it. So simple any child can make them. Outfit comes packed in neat Xmas box. Fully guaranteed or your money back.



Something New — Nothing like it on the market.

Better Light—Lasts Longer

400% more flashlight service for less money and your flashlight is always ready when you want it. Fits 1 1/2 x 6 1/2 in. tubular flashlight case. Only satisfactory thing to use around house, car, garage, anywhere. Order one of the following outfits today:

- Serviceable Flashlight Outfit—Flashlight case, heavily nickled, mazda lamp, complete with 6-cell "Make-Ur-Own" battery outfit..... **\$2.35**
- Renewal Outfit—Parts and Chemicals to make 6 cells complete..... **\$1.00**

Add 15c to cover postage. Attractive Proposition to Agents.
SERVICEABLE BATTERY & SUPPLY CO.
Exclusive Sales Agents
30 N. Michigan Ave., Dept. 25, Chicago, Ill.

is a specially prepared oiled linen, and from which blue prints are later made by passing sunlight, or light from an electric arc thru them. The tracing is made with regular black drawing ink with the usual drafting pens and instruments, the tracer simply having to follow the lines on the original drawing as laid out by the engineer-draftsman, whose drawings are usually made on some strong quality drawing paper. Tracings are often made of drawings in books or catalogs, photographs, maps and innumerable other illustrations and drawings met with in the thousand and one details of engineering work.

The young men of today are of course interested in all these things, for in this great field of engineering, which is ever expanding and growing at tremendous strides, the students today will become the draftsmen and engineers of tomorrow. Generally speaking, a tracer, presuming he is a young man of possibly sixteen to twenty years of age, will not remain as a tracer very long. Possibly in six months to a year, he may be given a position as junior draftsman, and in another year or so he may, if he is a conscientious student and a careful draftsman, be advanced to the position of a full-fledged draftsman or engineer-draftsman. In this connection it may be said that many young college men, graduates of the various engineering courses, first make their acquaintance with the commercial world via the drafting room. It is a very good way in which to learn the rudiments of their profession in a first-hand way, so that they are familiar with all details and work to be done by each department of a modern engineering organization.

BLUE PRINTING

Blue prints are not total strangers to any one today as everyone has seen blue prints at some time or other, even if they were nothing else than those of their own homes. There are various kinds of prints now in use, such as black prints and brown prints, but the time-honored blue print still holds its own to a very large extent, and millions of them are turned out every day, carrying with them masses of detail and calculations which serve as the connecting link between the engineering staff and the producing or manufacturing staff. The engineer talks with his drawings and the production expert and machinist interpret these drawings and construct the machine from them. Good drawings are not only necessary, but are demanded in the best engineering circles everywhere, and it has been said, and rightly so, that a good drawing or blue print should contain all the necessary views of the machine, and each part thereof as well as all necessary dimensions, such that this blue print can be given to a model maker or machinist, and the complete machine constructed accurately, without one word of explanation from the designer.

The old solar printing frame, which is pushed out an upper window on rails, with its glass face turned toward the sun, is still in use in many small drafting departments all over the world. There has been a new era in blue printing—thanks to the powerful electric arc light, and blue prints are made today a hundred times faster than they ever were before. One of these machines has a vertical glass cylinder while another type shown in one of the accompanying illustrations, has a horizontal glass cylinder,—the arc is turned on and the paper exposed. The light passes readily thru the uninked portions of the tracing cloth, but does not pass thru the inked lines and sections.

Stop Forgetting
Memory the Basis of All Knowledge
The Key To Success
The secret of business and social success is the ability to remember. I can make your mind an infallible classified index from which you can instantly select thoughts, facts, figures, names, faces. Enables you to concentrate, develop self-control, overcome bashiness, think on your feet, address an audience. Easy, Simple. The result of 20 years' experience developing memories of thousands.
Write Today for free booklet "How to Remember" and Copy-righted Memory Test, also how to obtain my FREE book, "How To Speak in Public."
Prof. Henry Dickson, Principal
Dickson School of Memory, 101 Hearst Bldg., Chicago, Ill.

POPULARITY FOLLOWS THE UKULELE
If you play quaint, dreamy Hawaiian music or latest songs on the Ukulele you will be wanted everywhere. We teach by mail 20 simple lessons; give you free a genuine Hawaiian Ukulele, music, everything—no extra. Ask us to send the story of Hawaiian music. You will love it. No obligation—absolutely free.
The Hawaiian Institute of Music
1400 Broadway, Dept. 5A New York

The Seneca Motorcar Built for the Owner \$1085.00
Simple, Sturdy construction. Low cost of up-keep and operation. Cantilever springs in rear. Comfortable E-Z riding.
4 cyl. - 27 H. P. 108 in. wheel base
Dealers Wanted Immediate deliveries. Fifth success, full year. Increased output. Liberal newspaper advertising in dealers' territory. Wonderful opportunities. Write or Wire NOW.
THE SENECA MOTORCAR CO., 41 Seneca Factory, FOSTORIA, OHIO

IS THE BIBLE TRUE?
You MUST read the remarkable book that has been suppressed over 100 YEARS. Sent by Mail prepaid only 50c. If, after you read this sensational masterpiece, you do not think it is worth TEN TIMES 50c we will refund your money. Know the Truth! You will be Startled!
Order at once
Truth Pub. Co., Dept. A.E., 1400 B'd'wy, N. Y.

HEAD ACHES, NEURALGIA, FLU
WOMEN'S ACHES
ASK FOR 'AK' TABLETS

SAVE 25% to 60% on slightly used **GRAFLEX-KODAKS**
Cameras and Lenses of every description. Equal to new. Save money. Write now for Free Bargain Book and Catalog listing hundreds of money-saving bargains in slightly used and new cameras and supplies. All goods sold on 10 days' Free Trial. Money back if not satisfied. You take no chances dealing with us. We have been in the photographic business over 18 years. Write now.
CENTRAL CAMERA CO., Dept. 171, 124 S. Wabash, Chicago

Handwriting Tells You Secrets
Be successful. Find out what holds you back. Send us an ink specimen of your handwriting and \$1.00. Our expert Graphologists will tell you your faults, virtues, talents, etc. Your \$1.00 back if you are not satisfied.
ROBERT R. ROSS, 110 West 40th St., N. Y.

Send for a Complete Catalog of **MASONIC BOOKS Jewelry and Goods**
REDDING & CO.
Publishers and Manufacturers
200 Fifth Avenue, N. Y.
Dept. 5

BE A BANKER
Prepare by mail in spare time for this attractive profession in which there are great opportunities for both men and women. Send at once for free book "How to Become a Banker," by EDGAR G. ALCOHN, President, American School of Banking, 114 McLane Bldg., Columbus, O.
BE AN EXPERT
Inman
Wonderful, new device, guides your hand; corrects your writing in few days. Big improvement in three hours. No failures. Complete outline FREE. Write C. J. Ozment, Dept. 44, St. Louis, Mo.

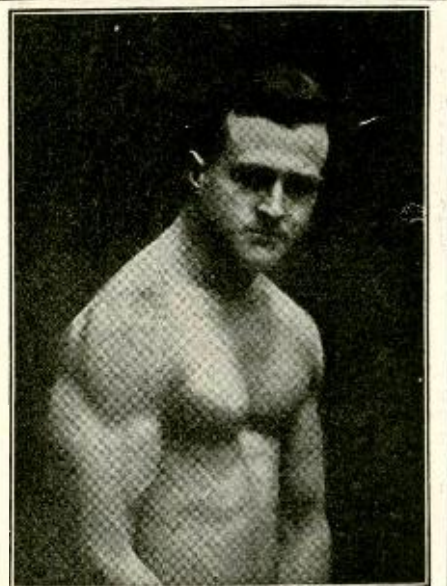

EARLE LIEDERMAN
The Acme of Physical Perfection
A Marvel of Strength
I have found the short cut to physical perfection and health. I have applied it to my own body and have trained many of the world's strongest men by this same method. I can positively make you a MARVEL OF STRENGTH by this most direct short method.
Send for MY NEW BOOK "Muscular Development"
It tells the secret. Handsomely illustrated with 25 full page photographs of myself and some of the world's best athletes whom I have trained. This valuable book and my special offer will be sent on receipt of 10c, stamps or coin, to cover cost of wrapping and mailing. Don't delay! Send for it now, while it is on your mind.
EARLE E. LIEDERMAN
Dept. 216 203 Broadway, New York

Rider Agents Wanted

In every neighborhood to ride and exhibit a sample RANGER bicycle furnished by us. Choice of 44 styles, colors and sizes in the famous Ranger line. Mead Rider Agents make big money in spare time hours—after school or work.

30 Days Free Trial
is allowed on every RANGER bicycle. We prepay freight charges. If not pleased the trial costs you nothing.

Factory - To - Rider
We sell bicycles made in our own big factories DIRECT TO THE RIDER—giving you a superior product at greatly reduced cost. Save time, money and trouble by dealing direct with our great Factory organization. Satisfaction in every detail guaranteed or money promptly refunded.

EASY Payments
Nine months to pay if desired—at a small advance over our special cash prices.

TIRES Lamps, Wheels, parts and supplies at half usual prices are also fully described and illustrated in the big free Ranger Catalog.

SEND NO MONEY, but write us today for factory prices, liberal terms and if desired Rider Agents Plan.

MEAD CYCLE COMPANY
Dept. R.A.—107 Chicago

Mend Your Pots, Pans and Toys and do all Metal Repairing with



SOLDERALL 25c PER TUBE
TORCH \$1.25

A PASTE THAT TURNS INTO METAL WHEN HEATED

A match will do it. Requires no acid or soldering iron. Joins or repairs wires, metals or metalware. Sold by hardware and electrical stores, or sent by us postpaid.

SOLDERALL CO., Dept. 9
129 Sussex Ave., Newark, N. J.

COMBINATION SET Tube and Torch Complete \$1.50

Used by U. S. and Allied Governments in War

HAIRMODE

Dresses the Hair



Keeps it Dressed!

Stubborn, wiry, mussy unruly hair becomes silky and beautiful. Gives it that lovely gloss characteristic of the hair of stage and screen stars of both sexes. Fine for the scalp—a tonic as well as a beautifier. Favorite of both MEN and WOMEN. Guaranteed harmless and greaseless. TRIAL BOTTLE, postpaid, 50c. Larger size (three times quantity) \$1. Satisfaction or price refunded. Order TODAY.

Husgray Laboratories, Dept. 12 Chicago

LEARN ENGINEERING

Expert electrical engineers are being paid fabulous salaries—thousands needed today. We give you personal and thorough training—practical, technical courses 3 months to 2 years under expert engineers in electricity, steam, gas, auto, armature winding, drafting, etc. Extensive laboratory and shop equipment. Not a trade school. Training is condensed—if your time is limited, come to the Finlay Engineering College—only one of its kind in the West. Day and night sessions—enroll anytime. Write for FREE catalog, a post card will do.

FINLAY ENGINEERING COLLEGE
1003 Indiana Ave. Kansas City, Mo.

REBUILT ELECTRIC MOTORS

General Electric Westinghouse Crocker-Wheeler Emerson Century Wagner etc.

All Motors Guaranteed For One Year

Motors bought, exchanged and repaired

ELECTRICAL SUPPLIES
Wholesale Prices

Sockets, wire, tape, loom, fuses, switches, cut outs, etc. New illustrated catalogue free. Satisfaction guaranteed or money refunded.

HYRE ELECTRIC CO.
631 S. Dearborn St. Chicago, Ill.

The blue print paper is then removed from the machine. In the earliest model of the electric blue printer, the paper had to be removed from the machine and past thru a developing and fixing bath, and then washed. In the later model of the horizontal drum type, the developing is done right in the machine itself, and the finished blue prints are reeled out in a continuous roll at the other side of the machine, in a very short space of time.

THE TRIUMPH OF THE ENGINEER—THE FINISHED MACHINE

The happiest day of an engineer's life occurs when his first machine or device has been finished and proven successful under test. When the machine, installation or device is finally finished by the workman then the engineer, and frequently the consulting engineer, if there is one on the staff, is invited to witness the test of the apparatus. These tests are of the utmost importance, and in all well-regulated engineering establishments having an engineering department, it is seen to that both the eventual customer for the machine, who is to use the device, as well as the designer, are satisfied that everything is right and as it should be. Electrical machinery is tested by voltmeters, ammeters, watt-meters, and in the case of motors and dynamos, the speed is carefully checked. Frequently, during the test by speed indicators or tachometers, many other electrical and mechanical qualities are carefully measured under the direction of the designer. Several of the large electrical manufacturing companies in America, including the General Electric and the Westinghouse Electric and Manufacturing Companies, operate very elaborate testing laboratories, for their electrical, steam and other machinery, and here it is that many of our engineers just out of college gain their first practical experience in the commercial application of their studies. The work is intensely interesting, and if the student takes up this work, or enters one of the testing engineering courses, conducted by these large electrical companies, and if he has the real making of an engineer in him, then he will never regret his experience in this work. From this experience as a basis, the conscientious engineering aspirant will build his future career, and we know of no better foundation to start from.

In closing, it should be mentioned that naturally every machine design does not fulfill its performance, as was theoretically intended and, of course, there are a myriad of reasons why it may not do so. Perhaps the iron, for instance, used in constructing the core of a magnet, dynamo or motor, is not of the quality which the engineer who designed it originally conceived it to be, and therefore his calculations are upset in spite of himself, no matter how elaborate they may have been. Here an interesting example of electrical engineering is brought to light. The layman might reasonably ask at this juncture, how could the electrical engineer know how many lines of magnetic force per square inch of cross-sectional area that the iron in his finished dynamo or magnet is going to carry and what magnetizing force in ampere-turns will be required to produce this magnetic strength of field in the grade of iron specified to be used. As a matter of fact, every grade of iron varies in its magnetic qualities, and the only sure way to ascertain before designing the machine, just what performance one may expect of it, is to procure samples of the actual iron, or "run of iron," and have a permeability test made in the electrical testing laboratory. From these tests he will then know the magnetizing force required to produce the desired magnetic flux in lines per square inch of cross-section in the iron or steel.

Big Money for Boys!



Learn ELECTRICITY

There is a wonderful opportunity right now for boys who like electricity. Boys who are ambitious and will train themselves in spare time can step into positions just as soon as they are ready. Good salaries are offered to start with splendid chances for rapid promotion.

For 28 years the International Correspondence Schools have been training boys for success in electricity and over 200 other subjects. They will help you prepare right at home for a position in the line of electrical work you like best—or in any other work that appeals to you. Thousands of boys, through I. C. S. training, have stepped into fine jobs, but never were opportunities so great as now.

Let the I. C. S. help you. Choose the work you like best in the coupon below, then mark and mail it today. This doesn't obligate you in the least, and it will bring you information that will start you on a successful career. This is your chance. Don't let it slip by. Mark and mail this coupon now.

INTERNATIONAL CORRESPONDENCE SCHOOLS

BOX 6216, SCRANTON, PA.

Explain, without obligating me, how I can qualify for the position, or in the subject, before which I mark X.

- | | |
|--|---|
| <input type="checkbox"/> ELECTRICAL ENGINEER | <input type="checkbox"/> CHEMICAL ENGINEER |
| <input type="checkbox"/> Electrician | <input type="checkbox"/> SALESMANSHIP |
| <input type="checkbox"/> Electric Wiring | <input type="checkbox"/> ADVERTISING MAN |
| <input type="checkbox"/> Electric Lighting | <input type="checkbox"/> WINDOW TRIMMER |
| <input type="checkbox"/> Electric Car Running | <input type="checkbox"/> SHOW CARD WRITER |
| <input type="checkbox"/> Heavy Electric Traction | <input type="checkbox"/> OUTDOOR SIGN PAINTER |
| <input type="checkbox"/> Electrical Draftsman | <input type="checkbox"/> RAILROADER |
| <input type="checkbox"/> Electric Machine Designer | <input type="checkbox"/> ILLUSTRATOR |
| <input type="checkbox"/> Telegraph Expert | <input type="checkbox"/> DESIGNER |
| <input type="checkbox"/> Practical Telephone | <input type="checkbox"/> BUSINESS MANAGEMENT |
| <input type="checkbox"/> MECHANICAL ENGINEER | <input type="checkbox"/> PRIVATE SECRETARY |
| <input type="checkbox"/> Mechanical Draftsman | <input type="checkbox"/> BOOKKEEPER |
| <input type="checkbox"/> Ship Draftsman | <input type="checkbox"/> STENOGRAPHER and Typist |
| <input type="checkbox"/> Machine Shop Practice | <input type="checkbox"/> Cert. Pub. Accountant |
| <input type="checkbox"/> Toolmaker | <input type="checkbox"/> Traffic Management |
| <input type="checkbox"/> Gas Engineer | <input type="checkbox"/> Commercial Law |
| <input type="checkbox"/> CIVIL ENGINEER | <input type="checkbox"/> GOOD ENGLISH |
| <input type="checkbox"/> Surveying and Mapping | <input type="checkbox"/> STATIONARY ENGINEER |
| <input type="checkbox"/> MINE FOREMAN OR ENGR' | <input type="checkbox"/> CIVIL SERVICE |
| <input type="checkbox"/> ARCHITECT | <input type="checkbox"/> Railway Mail Clerk |
| <input type="checkbox"/> Architectural Draftsman | <input type="checkbox"/> Textile Overcater or Supt. |
| <input type="checkbox"/> PLUMBING AND HEATING | <input type="checkbox"/> AGRICULTURE |
| <input type="checkbox"/> Sheet Metal Worker | <input type="checkbox"/> Penmanship |
| <input type="checkbox"/> Navigator | <input type="checkbox"/> Penmanship |
| | <input type="checkbox"/> French |
| | <input type="checkbox"/> Automobiles |
| | <input type="checkbox"/> Italian |

Name _____ 7-20-16

Present Occupation _____

Street and No. _____

City _____ State _____

I TEACH Penmanship BY MAIL



I won World's First Prize for best course in Penmanship. Under my guidance you can become an expert penman. An amazing many of my students are instructors in commercial colleges at high salaries. If you wish to become a better penman, write me. I will send you FREE one of my favorite Pens and a copy of the Ransomer's Journal. Write today.

C. W. Ransom, 511 Essex Bldg., Kansas City, Mo.

"The Ellis Music Master Reproducer"

made for all phonographs. Pleases the most exacting music lover. Eliminates twang. Perfect harmony of accompaniments, individuality of artists' voices and instruments re-created from records in life like reanimation. It sells on its merits. Send 10c for booklets E "Hints to Music Lovers" and "Music Masters." Agents wanted.

J. H. ELLIS, P. O. Box 882, Milwaukee, Wisconsin

Raise Belgian Hares for Us



Wonderful profits easily made at home. We furnish class A stock and pay you \$7 to \$12.50 a pair and express charges. Interesting illustrated catalog and contract FREE.

United Food & Fur Association
329 W. 48th St., Dept. E, New York

Telephone Men
Use These a WEEK
FREE

ACCCEPT this free offer and use these great up-to-date books on the telephone in your own home or shop a whole week free.

We will send you all four volumes bound in genuine red morocco leather, 1728 pages and 2000 pictures, without one cent in advance.

Cyclopedia of TELEPHONY AND TELEGRAPHY

Everything about the telephone is explained in them in simple and plain language—theory—practice—operation—from the first experimental line to the modern equipment and complicated switchboards. Not one detail has been overlooked. Every vital fact that you need to make you an expert is in them.

Free Consulting Service

If you wish to keep the books on our easy terms of \$2.00 a month, we will include FREE a year's Consulting Membership in the American Technical Society, and you can have the services of our engineers and experts for one year as often as you wish to write in and ask for their help on any subject within the scope of the books.

Send the Coupon Now

Don't send any money. Just mail the coupon properly filled out and the books will come to you at once by express collect. Keep them a whole week and use them as if they were your own. Send them back to us if you want to, but give them a trial anyway, and if you keep them send us only \$2.00. You can send the balance of the special \$14.80 price the same way—\$2.00 each month. Give yourself a chance to make some real money—right now. Send the coupon before you turn this page.

American Technical Society
Dept. T-251 Chicago, U.S.A.

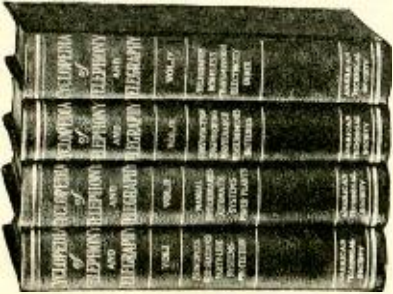

If you would rather have one of these sets for free examination instead of the one described above, cross out the name and price in this coupon and indicate your choice here by placing an (X) in front of the set you want.

- | | |
|--|---|
| <input type="checkbox"/> Law, 13 vols., \$44.80. | <input type="checkbox"/> Fire Prevention and Insurance, 4 vols., \$15.80. |
| <input type="checkbox"/> Electricity, 8 vols., \$24.80. | <input type="checkbox"/> Machine Shop Work, 6 vols., \$19.80. |
| <input type="checkbox"/> Auto Engineering, 6 vols., \$19.80. | <input type="checkbox"/> Accounting, 4 vols., \$14.80. |
| <input type="checkbox"/> Civil Engineering, 9 vols., \$29.80. | <input type="checkbox"/> Carpentry and Contracting, 5 v., \$19.80. |
| <input type="checkbox"/> Steam Engineering, 7 vols., \$21.80. | <input type="checkbox"/> Telephony and Telegraphy, 4 vols., \$14.80. |
| <input type="checkbox"/> Sanitary Heating and Ventilating, 4 vols., \$14.80. | |

AMERICAN TECHNICAL SOCIETY, Dept. T 251, Chicago
Please send me a set of Telephony and Telegraphy in 4 volumes, express collect. I will send you \$2.00 in 7 days and \$2.00 each month until I have paid \$14.80. If I don't want to keep the books I will return them to you in one week.

Name.....
Address.....
Reference.....

Calibrating Electrical Measuring Instruments

By THOMAS W. BENSON
(Continued from page 900)

If the result obtained is the same as the ammeter reading the instrument is for most practical purposes accurate.

The same procedure may be gone thru, increasing the current value each time till a maximum of five amperes is reached.

It is not usually feasible to correct the instrument itself so a correction chart is made and hung in a convenient place. This is laid out as shown in Fig. 3, actual current value being shown O to A, while O to B shows meter readings.

Thus any meter reading can be instantly converted to actual current by a glance at the chart.

For convenience the temperature of the gas and weight of the solution in the burette have been disregarded, these factors nearly balancing out at ordinary temperatures in this type of instrument.

Having an accurate ammeter, it becomes an easy matter to check a voltmeter. Knowing the relation between the voltage, amperage and resistance, as stated in Ohm's law, we can arrange the apparatus as shown in Fig. 4. A known resistance is put in the circuit at R; by passing currents of different strengths we can check the voltmeter with the formula:

$$I = \frac{E}{R}$$

A standard resistance can be purchased at a reasonable price and are rather difficult to construct. However, where necessary, a standard ohm at 20° C. can be made by using 98 feet, 8 inches of No. 20 copper wire. It should be remembered that copper wire changes in resistance with the temperature and the above limit should not be allowed to exceed 20° C. (68° F.) if results are to be reasonably accurate.

A correction chart can also be made for the voltmeter if necessary in the same manner as shown for the ammeter, plotting actual voltage against the meter readings.

A Small Rectifier for Charging Storage Batteries

By Elliott A. White
(Continued from page 899)

they are likely to slip past each other and thus overlap. The joints in each layer are covered up by the next layer above, the L-shaped pieces being put alternately on opposite sides. This makes a solid mass of iron in even layers. In Fig. 1 the solid lines across the face of the core indicate the joints in the top layer, the dotted lines the joints in the layer underneath; the joints in the third layer will again be in the position shown by the solid lines, and so on down thru the core. It will be noted that the L pieces are not symmetrical, one side being longer than the other. The purpose of this is to bring the joints out to the ends and away from the ends of the coils, where the core is likely to build up ragged. Of course symmetrical stampings may be used instead, in which case the joints will come at the ends of the window.

The core is built up with fair alignment to a thickness of 1 1/2", when the centers of the coils will be full. The cardboard lining keeps the corners of the iron sheets from catching in the tape as they are pushed

NUXATED IRON

"I believe my own great physical activity is due to my personal use of Nuxated Iron," says former Health Commissioner Wm. R. Kerr, of the City of Chicago.

"From my own experience with Nuxated Iron I feel it is such a valuable blood and body building preparation that it ought to be used in every hospital and prescribed by every physician in the country." Nuxated Iron helps to make healthier women and stronger, sturdier men. Used by more than 3,000,000 people annually in this country alone. Increases the strength and endurance of weak, run-down, nervous folks in two weeks' time, in many cases. Satisfaction guaranteed or money refunded. At all good druggists.

INVARIABLY

Four-months-for-a-dollar subscribers renew their orders for

THE PHOTO PLAY WORLD

because they find this high class publication indispensable for their library every month.

If you are not a regular reader, a dollar will bring you the next four numbers, each bigger and better than ever. When your subscription has expired you'll want the Photo Play World regularly.

The yearly subscription is \$3.50—35 cents on newsstands.

Sample copy on request.

THE DOWNS PUBLISHING COMPANY
Bulletin Building Philadelphia, Pa.

Don't Wear a Truss



BROOKS APPLIANCE, the modern scientific invention, the wonderful new discovery that relieves rupture will be sent on trial. No obnoxious springs or pads. Has a automatic Air Cushions. Binds and draws the broken parts together as you would a broken limb. No salves. No lies. Durable, cheap. Sent on trial to prove it. Protected by U. S. patents. Catalogue and measure blanks mailed free. Send name and address today.

C. E. BROOKS, 203C. State Street, Marshall, Mich

Life's Backbone

The success of your life depends on your **Health and Strength**

In a short time you can **Double Your Strength** and improve your **HEALTH**

More Resisting Power and Vim than you ever had. Send for my booklet **Life's Backbone**, which gives full description of the automatic exerciser—how it works, and what it will do for you. Send for it now.

PROF. ADRIAN P. SCHMIDT Suite 308 1951 Broadway, N.Y.

with the **Automatic Exerciser**

(The only one of its kind.)
If you are battling with functional weakness in any form—if you want to acquire



FUN

Noiseless Target Practice
Fit your .22 with a Maxim Silencer and get no end of fun this winter practicing in your backyard and basement.

MAXIM SILENCER
MAKES YOU A BETTER MARKSMAN

It eliminates recoil and all noise of the report, and steadies your aim. Direct from Dealer or Factory \$5.00. Write for Free Book of Stories.

FREE BOOK

MAXIM SILENCER CO.
89 Homestead Ave., Hartford, Conn.

LEARN LANGUAGES
AT THE
BERLITZ SCHOOL
28-30 WEST 34th STREET
Brooklyn, 218-230 Livingston Street

Washington, Boston, Philadelphia, Detroit, Chicago, Baltimore, Orange, Havana, Rio de Janeiro, Buenos Aires, Sao Paulo, Cordoba, Paris, London, Madrid, Rome, etc., etc.

FRENCH, GERMAN, SPANISH, ITALIAN, &c., &c.

By the Berlitz Method students learn not only to read and write, but especially to understand and to speak the foreign language.
TRIAL LESSONS FREE

Build Your Own PHONOGRAPH

It's Easy With Our Help
A few hours interesting work saves many dollars and gives you a machine exactly to suit your ideals. We furnish motors, tone arms, case material, blue prints and full instructions. Plays any record. You can make fine profit building phonographs for your friends.

Write Today for Our Free Blue Print Offer. Agents wanted for our ready built Choralions.

Choralion Phonograph Co.
107 Monger Bldg., Elkhart, Ind.

SAVE OVER HALF



MEN'S SOX

BIG SAVING

\$2.35 Doz
Offer good this month only; exceptional value; excellent for long service; strong toe and heel; medium weight for year 'round wear; seamless; \$2.35 for full box.

SEND NO MONEY Write today. Sox will be sent postage paid. Pay only \$2.35 on arrival—no more. Money back at once if not satisfied. The risk is ours. Colors, black, white, brown.

Be sure to state size and color.

KENNETH HOSIERY MILLS
Dept. 7, 915 E. 54th St. Chicago

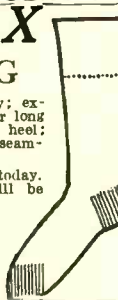

EASIEST SHORTHAND

Learn in 5 evenings home study. Then acquire speed with K. I. Shorthand. Amazingly simple, easy. Approved by experts. Write quickly as spoken. After brief pleasant practice. Favorite method for personal use; make notes at lectures, meetings; keep confidential diary. Big help in any profession or business; aid in your career. Used in Army, Navy, courts, commercial schools; by public and private stenographers, teachers. Slight cost. K. I. Shorthand—for busy people, including YOU. Free Lessons. Guarantee and Brochure with Testimonials free, postpaid. Address:

KING INSTITUTE, Et-300-Station F, NEW YORK CITY

Who wants these Boxing Lessons?

We guarantee we can teach you Boxing and Self Defense by mail. We will send complete course on approval. You can return it or pay \$5 in 5 days. Ask for it today.

MARSHALL STILLMAN ASSOCIATION
Suite E-1 No. 461 Fourth Ave., N. Y.

MUSIC TAUGHT FREE

You can read music like this quickly.

In Your Home. Write today for our booklet. It tells how to learn to play Piano, Organ, Violin, Mandolin, Guitar, Banjo, etc. Beginners or advanced pupils.

American School of Music, 57 Lakeside Bldg., Chicago



thru. As many pieces as possible should be forced in. The core should then be squeezed together in a large vise, after which it will be found that still more can be forced thru. When no more pieces will go in, the transformer is stood up on end on a flat surface and the core knocked into even shape by pounding it sharply but carefully with a hammer on all edges and on the bevelled corners. This will close all the open joints. To keep the core from humming under load, thin wedges of hard wood 1 1/8" wide by 2 1/4" long may be driven into the coils on top of the iron on both top and bottom sides of the transformer (4 pieces required). The ends may also be wound tightly with friction tape.

As the outside dimensions of the completed transformer are about 5" by 5 1/8" by 2 3/4", it can be enclosed in a box of these inside dimensions. The transformer shown in the photograph is contained in a cigar box with outside measurements of 5 1/2" by 6 1/2" by 5", but would go into one still smaller, as there is considerable spare room, especially as to depth. In placing it in the box, the ends of the core should rest on blocks of wood about 5/8" thick and long enough to fit tightly against the sides of the box, so that the surfaces of the coils just touch the bottom. Other similar blocks should be placed on top of the ends of the core, and the core clamped tightly between the two sets of blocks by means of bolts or screws. Screws or nails may then be put from the outside into the ends of the blocks to secure the transformer in place. It should then be wholly silent. The five leads are soldered to binding posts on the top of the box; or the two for the filament, kept as short as possible, are run thru holes drilled in the top and then to the terminal screws of the tube socket which is screwed to the top also, the other three leads being connected to binding posts as shown in the wiring diagram, Fig. 3.

The leads from the 110-volt winding go to two binding posts (1 and 2, Fig. 3) and thence to a cord and plug, or thru a fused switch, to a lamp socket or feed wires. One end of the 15-volt winding goes to a binding post (3) marked "positive", to which the positive side of the storage battery is connected for charging. The other end of the 15-volt winding and both ends of the 2-volt winding go to the socket and filament (an ordinary porcelain receptacle is used, as the Tungar tube has a standard Edison base). The negative side of the storage battery goes to a binding post (4) marked "negative", and thence to the anode of the tube, to which it is fastened by means of a Fahnestock or Eureka spring clip on the single wire projecting from the top of the tube. Care should be taken not to handle this wire roughly, as the seal is easily broken where the wire comes thru the glass, in which case the tube becomes useless.

In operation the current from the 2-volt winding of the transformer keeps the filament incandescent. Current from the 15-volt winding passes thru the battery and then thru the tube, from the anode back to the filament, thru the ionized gas. The Tungar tube is a rectifier or check-valve which allows current to pass in only the one direction. The alternating current is thus rectified into pulsating direct current for charging the battery, as only one-half of each wave is allowed to pass. This single tube outfit is known as a "half-wave" rectifier. Figure 4 shows how a "full wave" rectifier may be made with two tubes, furnishing 4 amperes of charging current. This rectifies both halves of the wave, but requires two 2-volt and two 15-volt windings instead of one of each, tho with no appreciable increase in the size of the transformer coils, and the same dimensions can be used. In this case the rectifier

Make YOURSELF Worth While



Don't stay in the class of "no-good" men who never are able to do anything that counts; who are despised or pitied by successful wide-awake people—as miserable, sickly failures in the business of life. You never can amount to anything, while chronic ailments have a grip on you, making your life miserable, turning you into a sickly grouch, and utterly unfitting you for successful work of any kind. Don't fool yourself by sticking your head in the sand, like an ostrich, and refusing to look the facts in the face; you won't "get better pretty soon"—you'll get worse, and go sliding down into the scrapheap of useless human wrecks, unless you

Brace Up and Build Yourself Up

STRONGFORT The Perfect Man

There isn't any doubt that you can do it, if you'll just WILL to do it, and go about it the right way. You can get rid of the constipation, indigestion, headaches, or other chronic ailments that are destroying all your chances of success in life; you can break away from any habits that are undermining your constitution and holding you back; you can strengthen your vital organs, build up your muscular system, sharpen your wits, and become well and strong and vigorous again—just as thousands of other sickly, discouraged men already have succeeded in doing. Patent medicines and druggist's dope didn't work a cure for them and won't for you. Pills and potions will only empty your purse and put money into the pockets of their promoters. **Take the Right Road**

Let Nature Help You Do It

I have spent my lifetime studying out Nature's ways of restoring lost health, strength, energy, manhood, to weakened, devitalized, unfortunate men. I have learned the secret of the wonderfully recuperative, rejuvenating power she exerts, when a few of her simple laws are known, observed and followed. It is the force on which every surgeon and medical man depends in the treatment of his most difficult cases. It never fails, when conditions enable it to be efficaciously applied.

Strongfortism

Strongfortism is the system of living life in Nature's way—as it was meant to be lived—and of getting the greatest enjoyment out of it. It is the system which has restored vigorous health, strength and energy to thousands of my pupils, many of whom had given up all hope of ever getting back the manhood they had lost. What Strongfortism has done for them it can and will do for YOU, no matter what your present condition or what causes brought you to it. Give Nature a chance to build you up! Strongfortism will show you how. I GUARANTEE that Strongfortism will improve you 100 per cent, if you will follow my directions for a few months.

Send For My Free Book

You will find "Promotion and Conservation of Health, Strength and Mental Energy" the most interesting book you ever read. It will tell you all about Strongfortism; how YOU can build yourself up, just as my other pupils have done and are doing in all parts of the world, make a MAN of yourself, with red blood, pep and energy that will give you a fair chance to make a big success of whatever you undertake. No patent medicines to buy; no complicated, expensive apparatus required; you can practice Strongfortism and get all the benefit of it in the privacy of your own bedroom, if you like, without in any way interfering with your present occupation. Don't put off sending for the book—IT'S FREE. Write today. Fill out the coupon below and enclose three 2c stamps for packing and postage, and I will mail you a copy at once, together with a special letter on the points in which you are particularly interested.

LIONEL STRONGFORT

Physical and Health Specialist
1136 Strongfort Institute, Newark, N. J.

CUT OUT AND MAIL THIS COUPON

Mr. Lionel Strongfort, Newark, N. J.

Dear Strongfort:—Please send me your book, "Promotion and Conservation of Health, Strength and Mental Energy," for postage of which I enclose three 2c stamps to cover mailing expenses. I have marked (X) before the subject in which I am interested.

- | | | |
|--------------|-----------------|--------------------|
| ..Colds | ..Deformity | ..Nervousness |
| ..Catarrh | ..Insomnia | ..Poor Memory |
| ..Asthma | ..Heartweakness | ..Rheumatism |
| ..Obesity | ..Short Wind | ..Poor Circulation |
| ..Headache | ..Flat Feet | ..Skin Disorders |
| ..Thinness | ..Constipation | ..Dependancy |
| ..Rupture | ..Biliousness | ..Round Shoulders |
| ..Neuritis | ..Torpid Liver | ..Lung Troubles |
| ..Neuralgia | ..Indigestion | ..Increased Height |
| ..Flat Chest | | |

Name _____ Write plainly
Age _____ Occupation _____
Street _____
City _____ State _____

Mechanical Engineering

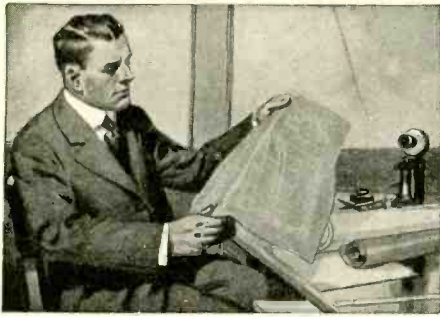

Learn at Home!

Employers everywhere are looking for men with mechanical ability. Splendid salaries and rapid advancement are offered.

There is an easy, delightful way in which you can learn right at home in spare time. For 28 years the International Correspondence Schools have been giving men and women just the training they need for success in mechanical engineering and more than 200 other subjects. Hundreds of thousands have stepped into good positions through I. C. S. help, but never were opportunities so great as now.

Let the I. C. S. help you. Choose the work you like best in the coupon below, then mark and mail it today. This doesn't obligate you in the least and it will bring you information that will start you on a successful career. This is your chance. Don't let it slip by. Mark and mail this coupon now.

INTERNATIONAL CORRESPONDENCE SCHOOLS BOX 6217, SCRANTON, PA.

Explain, without obligating me, how I can qualify for the position, or in the subject, before which I mark X.

- | | |
|--|--|
| <ul style="list-style-type: none"> <input type="checkbox"/> ELECTRICAL ENGINEER <input type="checkbox"/> Electrician <input type="checkbox"/> Electric Wiring <input type="checkbox"/> Electric Lighting <input type="checkbox"/> Electric Car Running <input type="checkbox"/> Heavy Electric Traction <input type="checkbox"/> Electrical Draftsman <input type="checkbox"/> Electric Machine Designer <input type="checkbox"/> Telegraph Expert <input type="checkbox"/> Practical Telephony <input type="checkbox"/> MECHANICAL ENGINEER <input type="checkbox"/> Mechanical Draftsman <input type="checkbox"/> Ship Draftsman <input type="checkbox"/> Machine Shop Practice <input type="checkbox"/> Toolmaker <input type="checkbox"/> Gas Engineer <input type="checkbox"/> CIVIL ENGINEER <input type="checkbox"/> Surveying and Mapping <input type="checkbox"/> MINE FOREMAN OR ENGR <input type="checkbox"/> ARCHITECT <input type="checkbox"/> Architectural Draftsman <input type="checkbox"/> PLUMBING AND HEATING <input type="checkbox"/> Sheet Metal Worker <input type="checkbox"/> Navigator | <ul style="list-style-type: none"> <input type="checkbox"/> OFFICIAL ENGINEER <input type="checkbox"/> SALESMANSHIP <input type="checkbox"/> ADVERTISING MAN <input type="checkbox"/> Window Trimmer <input type="checkbox"/> Show Card Writer <input type="checkbox"/> Outdoor Sign Painter <input type="checkbox"/> RAILROADER <input type="checkbox"/> ILLUSTRATOR <input type="checkbox"/> DESIGNER <input type="checkbox"/> BUSINESS MANAGEMENT <input type="checkbox"/> Private Secretary <input type="checkbox"/> BOOKKEEPER <input type="checkbox"/> Stenographer and Typist <input type="checkbox"/> Cert. Pub. Accountant <input type="checkbox"/> Traffic Management <input type="checkbox"/> Commercial Law <input type="checkbox"/> GOOD ENGLISH <input type="checkbox"/> STATIONARY ENGINEER <input type="checkbox"/> CIVIL SERVICE <input type="checkbox"/> Railway Mail Clerk <input type="checkbox"/> Textile Overseer or Supt. <input type="checkbox"/> AGRICULTURE French <input type="checkbox"/> Poultry Raising Italian <input type="checkbox"/> Automobiles |
|--|--|

Name _____

Present Occupation _____ 7-26-19

Street and No. _____

City _____ State _____

INDEX TO

ELECTRICAL EXPERIMENTER SCIENCE & INVENTION

FOR VOLUME 1, 2, 3, 4, 5

This index contains 24 pages and shows every article of interest that has been published since the inception of the magazine up to and including April, 1918.

It is absolutely indispensable to everybody interested in any kind of electrical research work. With it everything of importance in the advancement of electrical science during the last five years can be readily found.

Price **15c.** Postpaid

EXPERIMENTER PUBLISHING CO.
Book Dept. 231 Fulton St., N.Y.

terminals are connected to two binding posts, to which the battery is also connected with the polarity indicated by the signs as shown in the figure.

When the tube is operating a blue glow will be seen in the space between the anode cone and the filament and also between the filament supporting wires inside the tube. Under normal operating conditions this glow soon spreads and fills the bulb with a pink glow, particularly in the space above the anode. Considerable heat is developed, and for this reason the tube should not be mounted inside the box. The tube will not safely carry more than 2 amperes. This may be determined with a direct current ammeter in the battery leads, or, after some experience, can be judged with fair accuracy by the behavior of the tube itself. Since the life of the Tungar rectifier depends on the brightness of the filament, the latter should not receive more than the voltage specified. Too low a filament current will prevent rectification. Rectification will also be absent with too low a charging voltage. If the blue glow fails to appear or is too faint, or the charging current is less than 2 amperes, the inner end of the 15-volt winding should be tried on the other terminal of the filament, that is, connected to the other terminal screw of the socket. Failure of rectification will then mean increasing the number of turns on the charging winding, or on the filament winding, if one of these is at fault, or on the power winding if the voltage of both the others is too low.

Again, in case the current in the tube is excessive, a resistance may be inserted between binding post 4 and the anode—either an adjustable battery rheostat with a carrying capacity of 2 amperes, or a fixed resistance of nickel silver or alloy resistance wire wound in notches around a small fiber or Bakelite card (see photograph). Usually an ohm is enough to cut the current down to a proper value. Or a few turns may be removed from one or more of the windings, from the charging, power, or filament windings, in the order given. However, if the transformer is constructed as here described, and the supply voltage is 110, no resistance (and consequent waste of energy in heat) is required. The resistance card shown in the photograph is not used. The extra binding posts which appear in the photograph are the terminals of extra windings added during construction so that other tubes might be added to give full wave rectification with greater current carrying capacity, and also to furnish various voltages for other purposes, such as the operation of vacuum tubes for radio, as described by the author in the July, 1919, issue of this magazine.

The rectifier, if built as directed, consumes about the same power as an ordinary lamp, 50 watts—loses 20, filament 20, charging 10 or more. Altho the efficiency is therefore not very high—about 20%—at the same time the convenience of charging a battery where it stands by merely plugging into the commercial power circuit, more than makes up for its lack of efficiency. After charging it is sufficient to disconnect both sides of the power winding from the 110-volt supply, for except when the filament is lighted the Tungar tube forms an open circuit and the rectifier may be left permanently connected to the storage battery. To start charging, connect the 110-volt side of the transformer to the supply circuit. At ordinary rates for power, a 6-volt 40-ampere-hour battery may be fully charged for about 10c for current, a 60-hour for about 13c. To this should be added depreciation of the tube, which may be given roughly as 5c per charge, up, depending on filament temperature and rectified current. The total cost of operation is therefore approximately 15c and 20c per charge.

What 15 Cents Will Bring You From the Nations Capital

The little matter of 15 cts. in stamps or coin will bring you the Pathfinder 13 weeks on trial. The Pathfinder is an illustrated weekly, published at the Nation's center, for the Nation; a paper that prints all the news of the world and tells the truth and only the truth; now in its 27th year. This paper fills the bill without emptying the purse; it costs but \$1 a year. If you want to keep posted on what is going on in the world, at the least expense of time or money, this is your means. If you want a paper in your home which is sincere, reliable, entertaining, wholesome, the Pathfinder is yours. If you would appreciate a paper which puts everything clearly, briefly—here it is. Send 15c to show that you might like such a paper, and we will send the Pathfinder on probation 13 weeks. The 15c does not repay us, but we are glad to invest in new friends.

THE PATHFINDER, Box 576, Washington, D. C.

CLEARTONE PHONOGRAPHS

\$4.00 to \$200.00 Retail

Needles 45c per thousand in lots of 500,000
Motors \$1.35 to \$14.75 each. Tone Arms and Reproducers \$1.30 to \$5.75 per set. Main Springs 20c to 90c each. Records, Needles, Sapphire Points and Parts at reasonable prices.

Write for our 84 page catalogue, the only one of its kind in America, illustrating 33 different styles of Talking Machines and over 500 different Phonographic Parts.

LUCY 13 PHONOGRAPH COMPANY
Export Dept. 46B E. 12th St., N. Y., U.S.A.

Swing 4 in., 11 in. between centers, 17 in. total length. Shipping weight 13 lbs. Bed of lathe is machined. Workmanship first-class. Equipped with wood turning chuck. Can be fitted with 3 in. face plate and drill chuck as special equipment. Order one today. Price \$6.00 cash with order. **SYPER MFG. CO., DEPT. C. TOLEDO, OHIO**

Learn the Sign-Show Card Business

Be field-unlimited possibilities. Increase your sales by using a sign that will sell itself. Our course develops ability and originality. Work intensely interesting.

EARN \$25. TO \$75. WEEKLY everywhere. Our course covers every phase of work completely and thoroughly. Our graduates command big salaries. Write for catalog, samples, guarantee and Free Outfit Offer.

DETROIT SCHOOL OF LETTERING, 681 D. S. L. Bldg. Detroit, Mich.

COPY THIS SKETCH

and let me see what you can do with it. Many newspaper artists earning \$30.00 to \$125.00 or more per week were trained by my course of personal individual lessons by mail. PICTURE CHARTS make original drawing easy to learn. Send sketch of Uncle Sam with 6c in stamps for sample Picture Chart, list of successful students, examples of their work and evidence of what YOU can accomplish.

Please state your age

The Landon School of Cartooning and Illustrating
1510 Schofield Bldg., Cleveland, Ohio

Learn Vaudeville Acting

Stage Work and Cabaret Entertaining successfully taught by mail. Your opportunity to enter fascinating, money-making profession—to travel—see the world as vaudeville actor or actress. My simple, easy, complete, Professional Course—only one of its kind—COVERS ALL BRANCHES. Develops Personality, Confidence, Skill and tells you just how to get on the Stage. Send 6c postage for illustrated booklet "All About Vaudeville." State age and occupation.

Frederic LaDelle, Sta. 271, Jackson, Mich.

SPECIAL KON-VER-TER SLIDE RULE

The Hamilton KON-VER-TER slide rule has over 8000 graduations and over 1800 characters on it, will handle anything in arithmetic, Algebra, Geometry or Trig. This slide rule is in use in all parts of the world and is much simpler to operate than others of similar lines. Does not require a wizard to use it.

Eventually you will get this rule, get it now and save the extra bother and expense. Utility rules \$1.00. Special De Luxe, white ivory celluloid \$2.50. Instructions free. Leatherette case 50c extra.

C. HAMILTON & CO.,
Dept. B 7 Water St., Boston, U.S.A.

DIAMONDS ON CREDIT

Write for Free Catalog. Over 2,000 illustrations of Diamonds, Watches, Jewelry. Select any article desired, have it sent to you prepaid. If satisfactory, return us one-fifth of the purchase price and keep it, balance in eight equal monthly amounts.

LOFTIS National Credit Jewelers Write Today.
Dept. H22 108 N. State St. **CHICAGO, ILL.** Stores in Leading Cities

GO INTO MOVING PICTURE BUSINESS

Small Capital Starts You

Our Catalog FREE. Show you how to earn \$25.00 to \$50.00 per day on our easy payment plan. Begin now and get your share. We sell everything. Write today.

Atlas Moving Picture Co.
Dept. 50 538 S. Dearborn St., Chicago



AUTO EXPERT
\$45 to \$75 a week

Learn Auto Engineering

The marvelous development of the automobile industry during recent years has created extraordinary opportunities for men who will specialize in this work. The future is unlimited, with good pay from the start.

Guaranteed Home Training

The American School home study course prepares students for Consulting or Designing auto work, or Superintendent of an auto manufacturing plant. A shorter course for auto operation and repair for chauffeurs and garagemen. Send for Free Bulletin and guarantee.

American School of Correspondence, Dept. A-261 Chicago

PROTECT GOOD TOOLS

Keep them safe from knocks, bangs, rust—yet handy and all together. The New Utility Chest illustrated is for garage and home use, for machinists, tool makers, masons, carpenters, repairmen, etc.

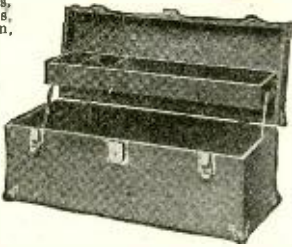

19 Styles and Sizes
Write for Catalog, Prices and name of nearest dealer. Ask about "Satisfaction or Money-Back" guarantee. If no dealer near you, write for special offer.

UNION TOOL CHEST CO., Inc.

36 Mill Street
Rochester, N. Y.

Star Storage Batteries
More Dependable
Lower in Price
The BEST Guarantee

Liberal discounts to dealers; write for particulars.

THE
STAR STORAGE BATTERY CO.

Manufacturers of
Automobile Starting and Lighting Batteries

Muncie, Ind. U. S. A.

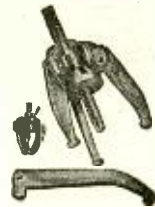

Says the Master Mechanic. The Greb Automatic Grip Puller is a One-Man Puller—Quick-acting, strong and simple in the extreme. May be locked in any desired position. A combination of two or three arms. Heavy Duty Size capacity 1" to 18"—Junior size capacity 1/2" to 7". Two sets of jaws furnished with each size.

Ten Days' Trial If your dealer or jobber does not have them we will send you one. Try it ten days. If not satisfactory, return to us and we will refund your money. We also make the GREB RIM TONER.
THE GREB CO., 230 State Street, BOSTON

Handy Binder

For the
Electrical
Experimenter

Holds and preserves 12 issues, each of which can be inserted or removed at will, without tools. Made of heavy material, extra reinforced at the back.

65c

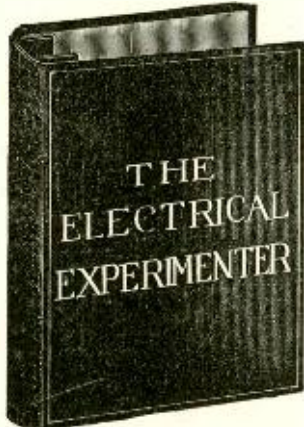

Add postage for 2 lbs.

Experimenter Pub. Co. Inc. Book Dept. 233 Fulton St., N.Y.

Is There a Sub-Electron?

By Rogers D. Rusk, M.A.

(Continued from page 894)

TABLE I

Early values of charge of electron.

Thomson.....	e=6.5	x10 ⁻¹⁰
Wilson.....	e=3.1	x10 ⁻¹⁰
Townsend.....	e=2.4	x10 ⁻¹⁰

Later values.

Regener.....	e=4.79	x10 ⁻¹⁰
Rutherford and Geiger.....	e=4.65	x10 ⁻¹⁰
Millikan.....	e=4.744	x10 ⁻¹⁰

TABLE II
Prof. Millikan's

Remarkable Agreement of Multiple Charges.

No.	Calculated	Observed
4x4.917	19.66	19.66
5x—	24.59	24.60
6x—	29.50	29.62
7x—	34.42	34.47
8x—	39.34	39.38

Science in Latest Movies

(Continued from page 884)

of course, foreign Secret Service agents try to battle with the wits and brawn of the American Secret Service agents and the heirs to the property. The scene at the left shows episode 4 of this mystery. Its story consists of the battle of wits, muscles and mechanisms. The "still," here reproduced shows the hero of this photoplay in a torture machine in which he is being slowly punctured by the iron spikes, which are gradually being closed upon him. Electric lights indicate the amount of pressure being applied which is readily regulated by a push button.

In the lower left picture is depicted a foreign agent in the act of demonstrating a machine which will destroy by its terrific discharge the American agent. An immense Oudin transformer is used, excited by a large transformer having a rotary gap of ponderous proportions connected to it.

The Structure of Electricity

By Dr. Alfred Gradenwinotz

(Continued from page 892)

can be derived from the color of the light given out by each individual particle: Gold particles about 8.5 millionth parts of a centimeter in radius thus will give out an orange light; gold particles 1/4 millionth parts of a centimeter in radius green, and mercury particles 1/4 millionth of a centimeter in radius, blue light. The figures found by these two methods respectively show a surprising agreement. There is, however, a third method by means of the Brownian movements just referred to.

The individual figures thus measured show that charges as small as one hundredth part of the would-be minimum charge can exist, thus proving the electron theory either to be unable to represent actual facts or to require a thorough transformation.

Another most interesting phenomenon brought out by Prof. Ehrenhaft's investigations is the fact that these minute particles are carried along by an intense beam of light either in the direction of the beam or in an opposite direction, according to the substance in question. This phenomenon, called *Photopheresis*, strikingly confirms the admissibility of Svante Arrhenius' daring hypothesis on the transport of germs of life along the trajectories of light beams from one celestial body to another.



Be a Doctor of Chiropractic

Build a successful career in this great profession—Chiropractic, the advanced science of treating disease through spinal adjustment. The demand for Chiropractors is constantly increasing. In larger numbers than ever before intelligent, thinking people are becoming convinced that it is the common sense and really scientific way to relieve pain and disease.

Learn At Home

We teach you by mail or in class instruction under the personal direction of a faculty of competent, practical Chiropractors. You can master this good paying profession and graduate with the degree of Doctor of Chiropractic while holding your present position. No special preliminary study and no more than a common school education are required. The cost is small—terms easy.

\$3000 to \$5000 a Year

The success of many Chiropractors has come so quickly as to be almost startling. Incomes of from \$3000 to \$5000 are not rare—some, upwards of \$10,000 a year. Dr. M. D. Moore, of Kentucky reports \$3000 a year; Dr. L. H. Roche, New Jersey, \$5000; Dr. Hanna, of Florida, over \$5000. You will receive the same kind of instruction which these Chiropractors received. Your prospects will be as bright as theirs. There is no reason why you should not do as well or better.

22 FREE Charts Lithographed and printed in colors. Actual value \$31.50. On this offer you get them all free. Send coupon for facts about this free offer—also 72-page Free Book which tells all about Chiropractic and its wonderful possibilities. This is your big opportunity to enter a dignified profession, be your own boss, be occupied in pleasant, profitable work and become independent. Mail coupon today.

AMERICAN UNIVERSITY

Manierre Bldg., Dept. 682 Chicago, Ill.
Without cost or obligation send me by mail, your new illustrated 72-page book and your Free Charts Offer.

Name.....
Address.....
City..... State.....



THE MIDGET SLIDE RULE will solve any problem in addition, subtraction, multiplication, division and proportion. A Log-Log Scale gives any root or power of any quantity. Gives Logarithms, Sines, Tangents, Cosines, Cotangents and the decimal equivalents of fractions to six figures. It is grease and water proof and will give years of service. This rule is not to be compared with the paper utility rules which sell for \$1.00 and are put together with paper fasteners. It is accurate, simple to operate and most complete rule made. Our refund guarantee protects you from loss or disappointment. An instruction book 16 pages, 12 illustrations, is sent with each rule. Diameter of rule 4 in. Made in two models: Metal (white case) \$4.00; White Celluloid, \$1.25. Leather Case 50c extra. Send for catalogue of Slide Rules. Your money back if you are not satisfied. Gilson Slide Rule Co., Niles, Mich.

to operate and comparison shows that it is undoubtedly the fastest and most complete rule made. Our refund guarantee protects you from loss or disappointment. An instruction book 16 pages, 12 illustrations, is sent with each rule. Diameter of rule 4 in. Made in two models: Metal (white case) \$4.00; White Celluloid, \$1.25. Leather Case 50c extra. Send for catalogue of Slide Rules. Your money back if you are not satisfied. Gilson Slide Rule Co., Niles, Mich.

A STEFFEY MOTOR



on your wheel will convert it into a practical and successful high grade motorcycle that will cost you less to operate than the more expensive machines. Write at once and secure lowest factory prices. Excellent opportunity for agents. Send stamp.

STEFFEY MFG. CO., Dept. E. 5025 Brown St., Phila. Pa.

KNOW COSTS

ACCOUNTANCY

Be a Cost Expert. Earn \$3,000 to \$10,000 yearly. C.P.A.'s teach you thoroughly in a few months by our New Home study system—Low Cost—FREE BOOK International Accountants Society, Dept. 39N 2626 S. Michigan Ave., Chicago

Famous Violet Ray Treatment

for Health, Vitality and Beauty

Now Possible in Your Own Home

A new machine has been perfected by scientists which enables anyone to enjoy the benefits of the Violet Ray treatment at home. The tonic effect of Violet Rays upon the system—how they are used to increase health and strength and to overcome specific disorders of the body.

FOR many years the wonderful results to be obtained through the application of electricity to the body have been known to scientists. Early investigation and experimentation opened up amazing possibilities for the future development of electricity as a curative agent and a vital source of health. Probably we all recall the first crude contrivance of a storage battery in a box from which a mild current of electricity could be passed through the body. Then came electric vibrating machines which, however, simply made use of the principle of mechanical massage and did not apply the action of electricity itself to the organs of the body.

The Discovery of Violet Rays

It was Nikola Tesla, one of the most brilliant of modern scientists, who mystified the world with the discovery of the peculiar Violet Ray. Tesla had found a way to convert a current of electricity into high frequency discharges. This can be described in simple terms as the diffusion of a solid current into a mist-like discharge. It is similar to a light, invigorating spray of water as compared to the force of a solid stream.

One of the most remarkable properties of the Violet Ray is its ability to penetrate solid objects, even including glass which acts as an insulator for electricity in its ordinary forms. We are all familiar with this phenomenon in the use of the X-Ray.

The Violet Ray Treatment

It was in the discovery of Violet Rays that the ideal way was found of applying electricity to the human body and obtaining all its wonderful, beneficial effects without any of the dangers that might attend its use in its more violent forms.

It is just like the refreshing, invigorating effects of a shower bath upon the system as compared to the shock of a solid torrent of water.

The Violet Ray, as used in the treatment of the body, sends a spray of mild, tiny currents through every part and organ, flowing through each infinitesimal cell, massaging it, invigorating it and vitalizing it. That is why after a Violet Ray treatment one is left with such a delightful feeling of health and buoyant energy. You have only a suggestion of this feeling in the effects of the ordinary massage. You know how restful and refreshing it is—how it brings a glow of health to your skin.

Now imagine this massage applied not only to the surface of the body, but to every part, every organ, every single cell, internal as well as external. No wonder that a Violet Ray treatment makes one feel "completely made over" and has such a delightful tonic effect upon the system. It acts upon the brain cells just as upon the other cells of the body, and that is why it is so often used by business men to overcome brain fog and mental sluggishness.

Wonderful New Machine Now Brings Violet Ray Treatments to Your Own Home

The Violet Ray treatment has long since passed its experimental stage. As its remarkable results were demonstrated, it received the endorsement of



Because of its effectiveness in clearing the skin of blemishes and beautifying the complexion, the Violet Ray machine is used for beauty as well as for health.

What Physicians and Users Say:

Trixie Friganza, well known actress, says: "Cheerfully will I add my praise for Violetta. It's the best 'pain chaser' and 'soother' I've had the good fortune to find. It's WONDERFUL. It cured my brother of neuritis. As for myself, I use it for facial treatments and general massage. I cannot say too much for it."

Dr. Bert H. Rice of Vinton, Iowa, says: "I have good results with the Violetta High-Frequency Instrument in all cases of neuralgia. Almost instant relief in Facial Neuralgia."

K. L. Allen, D. C., 205 Boone National Building, Boone, Iowa, says: "I have had very good results with the application of High-Frequency Current in cases of Paralysis, Rheumatism and Neuritis, and think it is a great help in drugless healing."

Dr. Daniels, Lisbon, North Dakota, says: "Have used the Violetta in such cases as Gout, Bronchitis, Pleurisy, Neuritis, Neuralgia and Lumbago, and find it very beneficial. In fact, I would not be without it in my office."

eminent physicians and scientists. Violet Ray machines became a part of the equipment of hospitals and sanitariums in the treatment of specific diseases and then were adopted by famous beauty specialists because of their effectiveness in eliminating skin diseases and blemishes such as eczema, blackheads, pimples, etc., and bringing the glow of healthful color to the complexion.

It is almost impossible to list all the various disorders for which Violet Rays are used, for, by restoring normal activity and life to every part of the body, they eliminate the abnormal conditions whose presence is generally responsible for any local ailment. For example, as the free circulation of blood through the body is established, congestion is removed, eliminating the cause of headaches, catarrh, nervousness and insomnia. The same principle applies to the treatment of neuritis, rheumatism, lumbago, indigestion and neuralgia.

Hitherto, however, the costly apparatus necessary for giving Violet Ray treatments has limited them only to the well-to-do who could afford the time and money to go to establishments equipped with the Violet Ray machine.

But now scientists have perfected a new Violet Ray machine, operating on the same principle, but smaller in size, more convenient to use and infinitely less expensive in cost. This little ma-

chine is adapted to home use and requires no special electrical equipment. The wire which supplies the current simply fits into any electric light socket and the machine is ready for use. Where no current is available, special equipment is furnished at small extra cost.

Now, anyone can enjoy all the benefits of the famous Violet Ray treatment. Those who are suffering from some particular ailment will appreciate the wonderful help this handy new instrument brings to them. And others will be delighted to avail themselves of its wonderful tonic effects in creating health and strength, vitalizing the nerves, energizing the cells of the brain and body.

Already users of the machine have written enthusiastic letters to the manufacturers, telling of the results obtained through it—how it enables them to sleep better—how it has soothed their nervous troubles—how it has cleared and beautified the complexion. And even those who thought they were well before say that Violet Rays have brought them an entirely new feeling of health, strength and energy.

Try the Violet Ray Treatment Without Cost

In order that everyone may know what Violet Rays will do in his or her own particular case, the distributors of this new machine are willing to send it to anyone interested for free examination and trial. This liberal offer enables you to enjoy the delightful sensation of the Violet Ray treatment without any cost or obligation to buy unless you decide that you want to keep and own the machine. It is only necessary to mail the coupon below and you will receive full details of this special free trial offer.

Interesting Book Sent Free

It is impossible to tell in this small space all about the Violet Ray—what it is and how it acts and all the disorders and diseases it is used to treat successfully. But an interesting book has been prepared, fully illustrated, which describes in full the Violet Ray treatment and explains the new Violet Ray machine for home use. It tells just how to use the machine to get the same results as are obtained by physicians, drugless healers, sanitariums and beauty specialists. A copy of this book will be sent free upon receipt of your request on a postal card or the coupon below.



This man is using the Violet Ray machine for a local trouble—in this case rheumatism. Clothing offers no obstruction to the passage of the Violet Rays.

As the special Ten-Day Trial Offer is made for a limited time only, in order to introduce this remarkable machine and to enable you to see for yourself just what it is and how it operates, you are urged to send for particulars at once. Just write your request on a postal or fill in the coupon and send it to the manufacturers. There is absolutely no cost or obligation in doing this. Address

VI-REX ELECTRIC CO., Dept. 41
326 West Madison St., Chicago, Ills.

VI-REX ELECTRIC CO., Dept. 41
326 West Madison St., Chicago, Ills.

Please send me your free book and particulars of your Ten-Days Free Trial Offer, without any cost or obligation on my part.

Name

Street (or R.F.D.)

City State

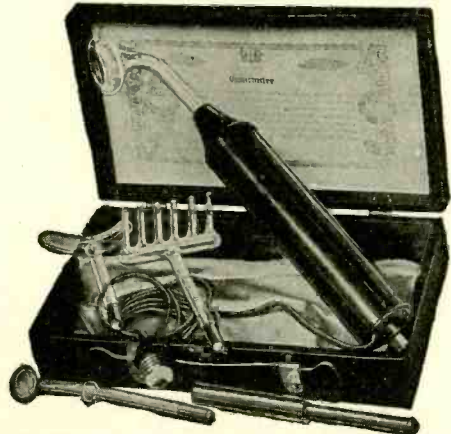

This illustration shows the wonderful new machine which enables anyone to enjoy the remarkable Violet Ray treatment at home.

You benefit by mentioning the "Electrical Experimenter" when writing to advertisers.

Opportunity Ad-lets

YOU will find many remarkable opportunities and real bargains in these columns. It will pay you to read and investigate the offerings made every month by reliable firms, dealers and amateurs from all over the country. No matter what you may be seeking, whether supplies, automobile accessories, the opportunity to make money, or anything else, you will find listed here the best and most attractive specials of the month.

Advertisements in this section nine cents a word for each insertion. No advertisements for less than 75c accepted. Name and address must be included at the above rate. Cash should accompany all classified advertisements unless placed by an accredited advertising agency. Ten per cent discount for 6 issues, 20 per cent discount for 12 issues. Objectionable or misleading advertisements not accepted. Advertisements for the March issue must reach us not later than February 8.

The Circulation of the Experimenter is over 130,000 and climbing every month

EXPERIMENTER PUBLISHING CO., INC., 233 Fulton Street, New York, N. Y.

Auto Accessories.

Tires—Direct to you prices. Exclusive representatives wanted each locality to use and sell Mellinger Extra Ply Tires. Guarantee Bond 8,000 Miles. Sample Sections furnished. Mellinger Tire Company, 980 Oak, Kansas City, Missouri.

Auto Motors and Supplies. Buick, Hupp, Franklin, Michigan, Everett, Hudson, Chalmers. Both water and air-cooled motors, \$40.00 each and up. Bosch Magnets, \$15.00 each and up. Presto Tanks, \$5.00. Coils, Carburetors, Head Lamps, Horns, Air Compressors, Generators, Starters. Write for bargain bulletin second hand auto accessories. Johnston, West End, Pittsburgh, Pa.

Battery Charging Pays Big Profits. City current or gas engine operates. Easy terms. Hobart Brothers, Troy, Ohio.

Chain-o'-Spark, the Superplug. Absolutely new principle. Sparks the unsparkable. Fires the unfireable. Runs Clean. Automobilst's delight. Salesman's fortune. Write. Chain-o'-Spark, 330 Northwestern Building, Minneapolis, Minn.

Fords Start Easy in Cold Weather. Will run 34 miles per gallon on cheapest gasoline or half kerosene using our 1920 carburetors. Increased power; styles for all motors; can attach them yourself. Big profits to agents; money back guarantee; 30 days' trial. Air-Friction Carburetor Company, 270 Madison St., Dayton, Ohio.

Wanted—Good live selling agents for our garage testing instruments and publications. Write for catalogue and particulars. H. E. Phillips & Company, Service Division, Union City, Ind.

Aeronautics.

100 Model Aeroplanes. Good flyers. 15c brings working Drawings and Prices. F. Bruland, Redford, Mich.

Auctioneers.

Auctioneers—Make big money. Free catalogue. Carpenter's Auction School, Kansas City.

Authors—Manuscripts.

\$50 to \$150 a Week writing Stories and Photo-Plays. Previous Acceptance Not Essential. Dept. 57, New York Literary Bureau, 141 W. 36th St., New York City.

Agents Wanted.

Agents, 200% profit. Wonderful little article. Something new, sells like wildfire. Carry right in pocket. Write at once for free sample. Albert Mills, Mgr., 1498 American Bldg., Cincinnati, Ohio.

Signs for store and office windows. \$50 week easily made. Chicago Sign System, G 326 River St., Chicago.

\$10 Daily refinishing chandeliers, brass beds, automobiles by new method, without capital or experience. Free particulars and proofs. Write today. Gunmetal Co., Avenue D, Decatur, Ill.

Wonderful Chance. Men's Shirts and Furnishings at wholesale rates or make \$10 daily as agent starting real business. Goodell Co., 104 Duratex Bldg., New York.

Mexican Diamonds flash like genuine, fool experts, stand tests, yet sell for 1-50th the price. Few live Agents wanted to sell from handsome sample case; big profits, pleasant work. Write today. Mexican Diamond Impmtg. Co., Box F1, Las Cruces, N. Mex.

Wonderful Adding Machine. Seven columns capacity. Retail for \$1.00. Sells itself everywhere. Most offices purchase several. Sensational agency proposition. L. J. Leishman Co., Dept. I, Ogden, Utah.

Make \$30 Next Saturday. Speederator for Fords selling like wildfire. Used by Ford Motor officials. Makes any Ford run like a Packard. Stops stalling and bucking. Put on quick, instant satisfaction. No holes to bore. Sell ten to twelve a day easy. Splendid profits and exclusive territory. Write quick for information. Address Perrin Company, 1042 Hayward Bldg., Detroit, Michigan.

Agents. Big returns, fast office seller; particulars and samples free. One Dip Pen Co., 12 Daily Record Bldg., Baltimore, Md.

Wanted—Agents to call on garages and service stations. Best line of testing instruments and publications on the market. Complete catalogue. H. E. Phillips & Company, Service Division, Union City, Ind.

Novelties.

Indian Relics, 44-page catalog free. Grutzmacher, Mukwonago, Wis.

Business Opportunities.

California Farms for Sale. Write for list. E. R. Waite, Shawnee, Oklahoma.

Amazing Profits manufacturing "Puffed Crisp." Delicious confection. Begin at home. Machine, instructions complete, \$6.50. Samples, 10c. "Besco," 3253-EN, Belleplaine Ave., Chicago.

Breed Canaries. Profitable pastime. Particulars free. Bird Farm, Lynnhaven, Virginia.

"Quick-Action Advertising—How it is Building Business, for the Progressive Advertisers of America": A little story of results, told by the advertisers themselves—not the publisher. You will be interested in reading this little booklet which we have prepared for prospective advertisers, a copy of which will be gladly mailed to you upon request. It tells you how to talk business with 1,000,000 intelligent, interested and responsive Americans every month—men who know what they want and who have the money to buy it. Write for particulars and rates—today. Douglas Wakefield Cutler, 225 West 39th St., New York.

Oklahoma Ranch Farm and Oil Lands. 500 acres LeFlore county, Oklahoma. Fine farm and ranch and near gas well that had 260 feet sand. \$7.50 acre. R. E. Lynch, Tulsa, Okla.

Learn Advertising and make big money. Prepare for this attractive profession in spare time. Complete course only \$1.00. R. P. Koehler, 156 W. Vernon, Los Angeles.

Dollars Yearly in Your Back Yard. No ginseng, mushroom dope. New ideas. Investigate. Particulars free. Metz, 313 East 89, New York.

Our Guaranteed mail-order plan is a winner. No "get-rich-quick" trash; but many have become independent operating this plan. Full particulars 25c. Nothing free. Nowry & Venice, 43 Washington St., Boston, Mass.

Money-Talks Magazine. Published for progressive men. Send for sample copy. 70-B Park Place, Newark, New Jersey.

Substantial manufacturing corporation wants capable men to establish branch and manage salesmen; \$300 to \$1,500 necessary. You handle own money. Will allow expenses to Baltimore if you will qualify. For particulars address Secretary, 416 N. Howard St., Baltimore, Md.

Would You Like to place your goods on the Philippine Market and from there branch out to include the rest of the Orient? 3,000 islands with 12,000,000 people Ready, Willing and Able to buy your goods. All that is needed is that they be told about them. Let us do the telling. We can do it in any language or dialect. We have a selling organization of 940 trained municipal agents. Advertising by all mediums. Translating, publishing and distributing of catalogs, circulars and class publications to live prospects. Classified mailing lists. Credit reports. Collections, Trade Marks registered. Send sample and literature for report. No competing lines handled. Write on letter head and enclose 10 cents for valuable booklet on marketing. "The Marketing Man, Inc." Advertising—Selling—Markertink. 224-229 Kneeder Bldg., P. O. Box 1509, Manila.

Money-Making Farms—19 States. \$10 to \$100 acre. Stock, tools, crops often included to settle quickly. Write for big illustrated catalogue. E. A. Strout Farm Agency, 150 EC Nassau Street, New York.

Make Big Money Opening Safes and Setting Combinations. Wayne Strong, Box 1430, Los Angeles, Cal.

Enter a new business. Earn \$3,000 to \$6,000 yearly in professional fees making and fitting a foot specialty, openings everywhere with all the trade you can attend to; easily learned by anyone at home in a few weeks at small expense; no further capital required; no goods to buy; job hunting, soliciting or agency. Address Stephenson Laboratory, 18 Back Bay, Boston, Mass.

\$30 a Week Earnings. I made it with a small mail order business. Continued my regular job daytime. Free booklet tells how. 2c postage. Al Exp Scott, Cohoes, N. Y.

Beginners. Complete "Mail Order System." C, Box 1005, Atlantic City, N. J.

You can earn over thirty dollars weekly working spare time for us. H. E. Phillips & Company, Service Division, Union City, Ind.

News Correspondents.

Earn \$25 Weekly, spare time, writing for newspapers, magazines. Experience unnecessary; details free. Press Syndicate, 566 St. Louis, Mo.

Help Wanted.

Dissatisfied with your pay, hours or work? Perhaps you can get just what you want in the Government Service, which needs immediately thousands of men and women over 18 for all kinds of work. You owe it to yourself to investigate. Just send name, address and this number, RP 281, for free information and advice. Earl Hopkins, Washington, D. C.

Secret Service Operatives and Detectives are in demand. Earn big money. Travel everywhere. Fascinating work. Learn this profession by home study. Particulars free. American School of Criminology, Dept. E., Detroit, Mich.

Detectives Earn Big Money. Excellent opportunity. Particulars free. American Detective System, 1068 Broadway, N. Y.

2000 Government Railway Mail Clerks Wanted. Men, women, 18 up. \$1300 year to beginners. Write immediately for list positions open. Franklin Institute, Dept. N-26, Rochester, N. Y.

Detectives make big money. Travel. be your own boss. Either sex. We instruct, small cost. Write Johnson's Detective School, 232 Sheldon Ave., Grand Rapids, Michigan. Dept. A.

Earn \$25 Weekly, spare time, writing for newspapers, magazines. Experience unnecessary; details free. Press Syndicate, 566 St. Louis, Mo.

Firemen, Brakemen, Baggage-men, \$140-\$200; Colored Porters, by railroads everywhere. Experience unnecessary. 897 Ry. Bureau, East St. Louis, Ills.

Wanted—Automobile experts. \$50 week. Learn easily while earning. Write immediately. Franklin Institute, Dept. N-806, Rochester, N. Y.

Stop Daily Grind, start silvering mirrors, auto headlights, tableware. Plans free. Clarence Sprinkle, Dept. 48, Marion, Indiana.

American Made Toys Wanted. An opportunity for home-workers on small scale and manufacturers on large scale. Unlimited quantities needed of toy soldiers, army, navy, marines, cannons, machine guns, warships and other toys and novelties. Greatest chance for industrious people for independent business. Enormous demand and future in American made toys, all over United States, Canada, Mexico and South America, with over 50,000 10 cent stores and toy dealers. This new American industry stands out conspicuously. Factories are established, people trained, machineries made. Christmas sets needed in millions this year. The great hit for 1920 without any competition. We are buyers of these goods all year, paying fixed prices. Attractive prices offered for painted goods. Experience or tools unnecessary. Hundreds and more made complete per hour. Casting form outfits from \$3.00 up. If you mean business, send for booklet and information free. Toy Soldier Manufacturing Co., 32 Union Square, New York.

Be a Mirror Expert. \$3-\$10 a day; spare time home at first; no capital; we train, start you making and silvering mirrors French method. Free prospectus. W. R. Derr, Pres. 579 Decatur Street, Brooklyn, N. Y.

Instruction.

Crystal Gazing the craze. Send self-addressed stamped envelope for free instructions. Zancigs Studio, Asbury Park, N. J.

Study Bacteriology, Public Health and Sanitation. Positions pay \$3,000 to \$5,000. Interesting home study course. Degree granted. We help secure positions. Write for prospectus. American College of Bacteriology, 3003 Stevens Bldg., Chicago.

Questions Answered, all subjects. Send for Circular 7. Answerall Information Bureau, 51 Cliff St., New York.

Cartooning, Comics and Lettering in fourteen easy lessons. Only \$5 postpaid. Over 300 illustrations. Sample Lesson 25c. Ernie's School, Elyria, Ohio.

Sten-o-Script takes Dictations, Lectures. Speeches, 200-300 words a minute. Wonderful! Scientific, Simple. Easily learned in few hours. Special Introductory Offer, 58c. Money refunded if not satisfactory. "Sten-o-Script," Tacoma, Wash.

"L. A.," \$1. Dissatisfied—money back. Long-hand abbreviated. Time-saving, educational. Vrooman, Box 706, Reno, Nevada.

Moving Picture Plays.

Earn \$1200 a Year in Spare Time writing photoplays. Experience unnecessary. Send for free book valuable information, special prize offer. Photo Playwright College, Box 278 E-9, Chicago.

Photoplays Wanted. Big prices paid. You can write them. We show you how. Free particulars. Rex Publishers, Box 175, E-9, Chicago.

(Continued on page 964)

(Continued from page 963)

Musical Instruments.

Violins. Deep, Mellow, Soulful—on credit. Easy terms for wonderful instrument. Get details today. Gustav Henning, 231 11th St., Miami, Florida.

Motor Engines and Dynamos.

Small Motors and Generators. Cancelled Government Contracts. A. C. Motors, \$9.50 each and up. 12 110-volt generators, \$26.50 each; battery-charging outfits, \$30 each and up. New motors 1/4-1/2 up to 5 H. P. for all phases and frequencies of current. Write for late bulletin. Bargains in motors and generators. Address Motor Sales Dept., No. 12, West End, Pittsburgh, Pa.

Motors, Electric.—We buy, sell, exchange motors of various sizes; large stock; prompt shipments. General Distributing Co., 22 West First St., Duluth, Minn.

Miscellaneous.

Guaranteed—"Titan," "Tufkote" roof paint, heavy bodied, waterproof, fireproof, limited period 60c. gallon, barrels; dustproof "Waxol" wood floor oil \$1.00 gallon; wizard leak repair mastic cement \$1.00. Martinek Company, 405 Lexington Avenue, New York.

Fine beautiful, evergreen, ornamental firs, any address, \$1.00. Order now. B. B. Lee, Sta. A., Vancouver, Wash.

"How to Read Thoughts." Mind Reading at any distance, 20c. "How to Hypnotize"—Cure Diseases. Give Astounding Exhibitions, \$1.00. "Silent Friend"—Key to Rapid and Honest Wealth, \$1.00. "How to Win," 362 pages. Success Assured, \$2.00. "Health Culture" Insures Vital Strength, 25c.; 5 Dozen Money Makers, 30c. Catalogue gratis. Science Institute, E-1336 Morse Ave., Chicago, Ill.

The Master Key is the best and most convenient for household use; opens 20 different locks. Sent postpaid on receipt of 10c, or complete set of three for 25c. Safety Key Holder Free. Sharpe Novelty Co., Paterson, N. J.

Wanted—Small Gasoline and Steam Engines, Small Lathes, Drill Presses and other light machinery. Will pay high cash prices for good material. Johnston, West End, Pittsburgh, Pa.

Big Mail for a stamp. C. E. Robinson, Portland, Conn.

150 Parodies on Latest Songs, 10c. Charles Dynes, Winchester, Ind.

For Advertisers.

Money? Jacobus Art Ads make small space pay big dividends. Price \$5.00. Write today. Jacobus Service, 1073 Sanford Ave., Irvington, New Jersey.

"Quick-Action Advertising—How it is Building Business for the Progressive Advertisers of America": A little story of results, told by the advertisers themselves—not the publisher. You will be interested in reading this little booklet which we have prepared for prospective advertisers, a copy of which will be gladly mailed to you upon request. It tells you how to talk business with 1,000,000 intelligent, interested and responsive Americans every month—men who know what they want and who have the money to buy it. Write for particulars and rates—today. Douglas Wakefield Coutlee, 225 West 30th St., New York.

For the Photographer.

Do you take pictures? Write for free sample of our big magazine, showing how to make better pictures and earn money. American Photography, 465 Pope Building, Boston, Mass.

Health.

Free—Stop using tobacco. We will give free information how to conquer habit easily and permanently. Results Guaranteed. Anti-Tobacco League, Dept. C., Omaha, Nebr.

Pyorrhea (Rigg's Disease—Bleeding or Swollen Gums). H. E. Kely, D. D. S., M. D., pyorrhea specialist for 15 years, has developed a successful home treatment for pyorrhea, purifying, healing, preventative. Full month's treatment, \$1 postpaid. Or write for free booklet. Pyorem Mfg. Co., 439 Seventh St., Brooklyn, N. Y.

Tobacco or Snuff Habit Cured or no pay; \$1 if cured. Remedy sent on trial. Superba Co., SA, Baltimore, Md.

Too Fat? Reduce weight easily, pleasantly, no self starvation, no strenuous exercise. Reliable, guaranteed. Obtain Oil of Korein at any busy pharmacy or write for free brochure to Korein Co., NA-300, Sta. F., New York.

Cigarette, pipe or chewing habit conquered. Guaranteed. Write for free brochure. Edw. J. Woods, TB-300, Station F, New York.

Office Devices.

Multigraphs, Addressographs, folders, duplicators, sealers, bought and sold. Office Device Company, 222-W North Wabash, Chicago.

Typewriters.

Startling Values in Typewriters \$15 up. Factory rebuilt. All makes. Shipped on trial. Write today for our Special Offer No. 158-A. Ribnsaver makes pale ribbons like new for one cent. Order today, 50c. postpaid. Whitehead Typewriter Co., 186 N. LaSalle St. Chicago, Ill.

Rubber Stamps.

Rubber Stamps made to order. McCaddon Company, Zanesville, Ohio.

Patent Attorneys.

Patents Procured—Trade Marks Registered—A comprehensive, experienced, prompt service for the protection and development of your ideas. Preliminary advice gladly furnished without charge. Booklet of information and form for disclosing idea free on request. Richard B. Owen, 130 Owen Bldg., Washington, D. C., or 2278-T Woolworth Bldg., New York.

Patents—Foremost word free. Write now. Metzger, Washington, D. C.

John M. McLachlen, Attorney at Law. Patents, trade marks, copyrights. 410 McLachlen Bldg., Washington, D. C.

M. F. Miller, Ouray Bldg., Washington, D. C., Patent Attorney, Mechanical and Electrical Expert. Best quality of work and results. Moderate charges. Advice free.

"Inventors' Adviser" sent free on request. William C. Linton, 918 F St., N. W., Washington, D. C. 363 University St., Montreal, Canada.

Patent Attorney, Consulting Engineer. High-class patent service in all its branches. Write for particulars. M. H. Loughridge, 1457 Broadway, New York.

Don't lose your rights to patent protection. Before disclosing your invention to anyone send for blank form, "Evidence of Conception," to be signed and witnessed. Form and information concerning patents free. Lancaster and Allwine, 242 Ouray Building, Washington, D. C., Originators of the form, "Evidence of Conception."

Patents—Herbert Jenner, patent attorney and mechanical expert, 622 F St., Washington, D. C. I report if patent can be had and its exact cost. Send for circular.

Inventions Patented, Trade-Marks Registered, Labels, Prints, Publications Copyrighted; prompt service, reasonable fees, plain advice; request detailed information before placing your business. Jaynes & Jaynes, 802 Kellogg, Washington, D. C.

Patents—Prompt, personal, efficient service by an attorney-at-law, skilled in all branches of Patent Practice. Over 12 years' actual experience; full information upon request. B. P. Fishburne, 330 McGill Bldg., Wash., D. C.

Patents—Fees in installments. Frank T. Fuller, formerly Lieutenant, Engineers, Washington, D. C.

Patent Your Own Inventions. Save attorney's fees; we prepare applications, furnish full instructions and give satisfaction. Free information. Carl Larsen Co., Park Row Bldg., New York City.

Inventors, send sketch of model of your invention for opinion concerning patentable nature and exact cost of applying for patent. Book, "How to Obtain a Patent," sent free. Gives information on patent procedure and tells what every inventor should know. Established twenty-five years. Chandlee & Chandlee, 414 Seventh St., N. W., Washington, D. C.

Millions spent annually for ideas! Hundreds now wanted. Patent yours and profit. Write today for free books—tell how to protect yourself, how to invent, ideas wanted, how we help you sell, etc. 212 Patent Dept., American Industries, Inc., Washington, D. C.

For Inventors.

"Sell or Finance Inventions. Read Money-Talks Magazine. Send for free sample copy. 70-B Park Place, Newark, New Jersey."

Inventors—We do experimental Model, Tool, Die and Jig Work; Light Manufacturing. Miller & O'Brien Mfg. Co., Saint Paul, Minn.

"Inventor's Guide" Free on request; gives valuable advice and information for all inventors. Write Frank Ledermann, Registered Patent Attorney, 17 Park Row, New York.

Inventors write me about patents. My fees payable monthly. Booklet free. Frank Fuller, Washington, D. C.

900 Mechanical Movements, also illustrations explaining 50 Perpetual Motions. My book, "Inventor's Universal Educator," fifth edition, tells how to procure and sell patents. Government and other costs. Covers the matter from A to Z. 160 pages elegantly bound. Contains noted decisions of U. S. Supreme and State Courts on patent cases. Mechanical Movements greatly assist inventors, suggest new ideas that may prove of great aid in perfecting inventions. Tells how to select an attorney. Has valuable information regarding Patent Sharks, Selling Agents and Brokers. Price \$2. Postage free everywhere. Fred G. Dieterich, 603 Ouray Bldg., Washington, D. C.

Inventions Wanted. Cash or royalty for ideas. Adam Fisher Mfg. Co., 205 St. Louis, Mo.

Patents for Sale.

Wanted—Partner to furnish money to patent for half interest. Brace Bit cut figures, letters, etc. W. E. Farr, Chickasha, Okla.

Personal.

Write to famous Hawaiian Beauties, Swimmers, etc., membership 25c. Hawaiian Correspondence Club c/o L. de Roo, Box 306, Honolulu, Hawaii.

The Salesman Wins. Thousands of positions open. We teach traveling salesmanship by mail and guarantee offer of position or refund tuition. For interesting particulars address Kansas Vocational Bureau, Miltonvale, Kansas.

Postcards and Pictures.

Membership in post card exchange one month, three art cards, lists, etc., 25c. Sophie Girard, Box 294, Pawtucket, R. I.

Rare Real Photos—Bathing beauties, models, the kind you want. Sample Dime. Write. Artiste, Auburn, Ind.

Make Your Own Phonograph. Particulars free. DeSelo-PhonE, P. O. Box 720, Attica, Indiana.

Build Your Phonograph. "Perfection" high-quality spring and electric motors, tone arms, reproducers. Wonderful results. Big saving. New catalog and building instructions mailed for ten cents. Indiana Phonograph Supply Co., Indianapolis, Ind.

Books.

Dear Reader. If Occult, New-Thought and Scientific books appeal to you, send for my catalog, it's free. I have books on Personal Magnetism, Concentration, Spiritualism, Clairvoyance, Seer-ship, Will, Mind, Hypnotism, Mesmerism, Character Reading, Healing, Mysticism, Success, Salesmanship, Mechanics, Entertainments, etc. A. W. Martens, J-49, Burlington, Iowa.

World-Romic System. Masterkey to all languages. Six textbooks, \$1.44; French chart, 37c.; Spanish, 37c.; aviation dictionary, \$1.50; French-English aviation dictionary, 6c. Languages, 143 W. 47th St., New York.

Crucified Seer Emmerich, Nativity, Egypt and Cana. 4 books, 20c. Klein Co., Brandon, Minn.

Mechanics. Learn how to read blueprints. Complete 169-page cloth bound book with 228 illustrations mailed for \$2.00. You cannot lose; your money refunded if not satisfied. Educational Institute, 139 Rowland Bldg., Detroit, Michigan.

Nature Laws every married and engaged person should know, 50c. Central Company, 609 Ninth Ave., New York.

Concordia contains essays, formulas, plans. Year's subscription 50 cents, trial 20 cents. Concordia Magazine, 9 Water, York, Pennsylvania.

World's best book for Auto Mechanics. Covers Elementary Electricity. Motor Car Electric Systems, The Gas Engine and Driving Cars. Nearly six hundred diagrams. Prepaid to you for \$2.50. Order to-day. H. E. Phillips & Co., Service Division, Union City, Ind.

Exchange.

Wanted. Phones, audion, other receiving apparatus. A. Walmsley, Star Route, Florence, Ala.

Buy, Sell, Exchange. Wireless and electrical goods. Murdock, Clapp-Eastham, Thordarson, Brandes, etc. Send 10c. stamps for our circulars listing new standard apparatus at less than manufacturer's prices. We have to exchange: Wireless, Electrical, Optical, Cameras, Printing Presses, Typewriters. Large list free. LaRoy Zehrbach, 10 College Ave., Hiram, Ohio.

For Sale. 5 acres in one Piece. \$50 cash or Bond at face value, in Wayne Co., Tenn. About 2 miles from Waynesboro, the county seat. Good cut over land. No improvements. Must sell at once. First money order or bond gets a Warranty deed. Will sell 10 acres for \$100. P. O. Box 184, Randolph, Nebraska.

Sell inch spark coil \$1.00. New Phones, 2,000 ohm., \$3.00. Send stamp for list. Earle Burns, 93 Union St., Athol, Mass.

Bicycle, slightly used, fully equipped. Will exchange for complete wireless outfit. 164 Stone Ave., Yonkers, N. Y.

Bargains—\$30 Meccano set \$13. \$15 Electric train \$5. Matthew Ehmke, 1936 Howe St., Chicago, Ill.

For Sale—1 horsepower steam engine \$10.00. Chemical laboratory \$10; other junk. Send for list. Carroll Fisher, 42 Putnam St., Somerville, Mass.

For Sale—1 1/2 H. P. 110-volt, 60-cycle induction motor, \$30.00; 1 1/4 KW. 500-volt DC generator, \$30.00; 1 hot wire meter, 0-5 amps., \$2.00; 1 hot wire meter, 0-5 amp.; 2 pair 200-ohm phones, each \$4.00; 2 telephone microphones, each \$1.00; motors, switches, sockets, rheostats, insulators, etc. Write for prices at once. J. E. Law, Sycamore Street, Clarksburg, W. Va.

Sell complete receiving set at bargain. P. Leary, 65 Kenwood Park, Springfield, Mass.

For Sale—Robbins & Myers 1/4-horse motor. Brand new, \$17. George Marx, Le Mars, Iowa.

Exchange—32 Winchester auto rifle for wireless apparatus. Geran Read, La Grange, Ind.

Sell. Loose Coupler, condenser, etc. Quick. Mariel Scherer, 110 West 80th St., New York.

Bargain—Telescope, six-inch objective (maker, Clark & Son), six-foot tube, Tripod mounting, three Eyepieces. Write for price. Wm. W. Peters, 1107 S. 8th Street, Burlington, Iowa.

Wanted—Receiving Set. Prefer Electro Importing Co.'s Sayville or Tuckerton Radio outfit. Harry Ritchey, St. Johns, Ohio.

Sell 1 K. W. 220-volt primary 60-cycle Thor-darson Transformer, brand new, \$18. Starrett, 2615 N. Fourth St., Columbus, Ohio.

For Sale—Two Motion Picture Projectors, cost \$450.00. Will sell cheap. Box 861, Roanoke, Va.

Sell—15-volume Encyclopedia (nearly new), \$10. Stamp brings particulars. Fred Higby, 1726 Fairview Ave., Boise, Ida.

(Continued on page 966)

ALSOP-ALL-SPARK

Address Reply in Duplicate to
DIRECTOR OF MILITARY AERONAUTICS
Washington, D. C.

ON REPLY PLEASE QUOTE
FILE NO.

WAR DEPARTMENT
OFFICE OF THE DIRECTOR OF MILITARY AERONAUTICS
WASHINGTON

January 19, 1919

From: Engineering Officer, Camp Morrison, Va.
To: Commanding Officer, Air Service Depot.
Subject: Supplemental Report on Test of Alsop Ignition Device.

1. In order to ascertain whether the device would insure ignition through plugs that were carbonized, cracked or rendered inoperative from other causes, one quart of oil above high level was placed in unit #9, the car was run until the motor died and could not be again started. The spark-plugs were then inspected and found to be heavily carbonized.
2. The Alsop Device was then attached, and within a short time all plugs were firing perfectly. The plugs were immediately removed and found to be clean - free from oil and carbon.
3. Then the Alsop was removed entirely from the car, motor was started again and ran for about four hours, then due to the excess oil still in crank-case, the plugs again became fouled and motor stopped. The heavily carbonized plugs were examined and replaced without cleaning.
4. The following day, Jan. 20th, the Alsop device was reinstalled with same results as before.
5. Later, a mixture of 50% kerosene and 50% gasoline was placed in the tank, no changes were made in the motor, carburettor or ignition device. The engine started as easily as with straight gasoline, developed greater power and continued to operate as above. No carbon formations were found on the plugs after using up the tank full of the above mixture.

Hyda Taylor
Lieut. A.S.M.A.

This Test Proves That THE "ALSOP-ALL-SPARK"

Saves fuel and spark plugs.
Fires dead carbon-choked plugs.
Causes perfect combustion.
Fortifies any ignition system.
Guarantees increase of gasoline mileage.

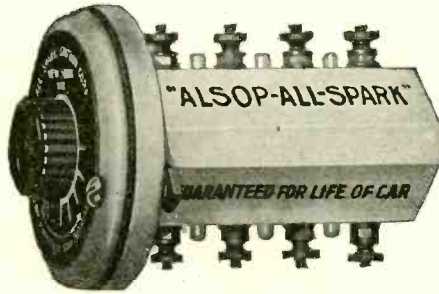

Does away with changing spark plugs.
Prevents running engine with a misfire.
Gives a more powerful spark.
Eliminates carbon and vibration.
Increases speed and power.

What the War Department found to be true about the "Alsop-All-Spark" is proven every day. Wherever this wonderful little device is installed owners enthuse over it. They find it will cause old, cracked, carbonized, and oil soaked plugs to give powerful sparks. It eliminates carbon, saves gas, develops greater power and insures continued driving without misfires.

DEALERS—HERE'S YOUR CHANCE

There's a constant and growing demand for such a device—one that is absolutely guaranteed—one that has no dangerous, exposed spark gaps, which may set a car afire, one that does not make a car hard to start or cause uneven timing.

Send \$7.50 for 4-cylinder device with money-back guarantee. Dealer discounts and our catalogue of Convincing Government Tests upon request.

DEALERS—AGENTS—SALESMEN—WANTED.

ALL-SPARK IGNITION CO., Inc.

13 X WATER ST.

NEW YORK

Electricity

taught by a practical man.

YOU CAN LEARN

By This Practical Method of Home Study



Instructions on the Electrical Slide Rule

A set of concise lessons on the use of the Electrical Slide Rule has been prepared by Mr. Burgess in response to many requests from those who desire to take up the use of this instrument which is invaluable to many electrical men.
A High Grade Slide Rule
in a leather case and the COMPLETE COURSE OF INSTRUCTION will be supplied at a VERY REASONABLE COMBINATION PRICE. Write for full information.

Hundreds of Burgess-trained men and boys have advanced to better positions by means of the practical electrical knowledge easily learned at home by this method. If you are willing to utilize a little of your spare time you can do the same.

For Beginners and Experienced Men

This home study course is based upon the years of practical electrical experience of Yorke Burgess who gives personal attention to each student. There is no limit to what you can accomplish with its aid. It is up to you.

Results of This Service

Practical electricians recommend this course to others. Students are invariably promoted and get better salaries. Over 80 per cent of the students are engaged in the electrical business. Over 15 per cent of present enrollment came through satisfied students. Beginners get employment in electrical work after taking the course a short while.

FIFTY-FIFTY

This method of learning PRACTICAL ELECTRICITY is supplied on EASY PAYMENTS, including apparatus, instruments, material, etc. Start any time—stop any time—your payments cease if you are not satisfied. Send for the BURGESS BOOK to-day. Gives full information without cost or obligation.

YORKE BURGESS, Superintendent

BURGESS ELECTRICAL SCHOOL, 745 E. 42nd Street, DEPT. A Chicago, Ill.

Satisfaction Assured

The Burgess Method is so universally successful that we give positive assurance of perfect satisfaction on completing the course or money refunded. There are no strings tied to this—you are the judge.

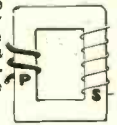

BURGESS BLUE BOOK ELECTRICAL MEN AND STUDENTS

Price \$1.00

A pocket hand-book for ELECTRICAL MEN and STUDENTS. Contains over 200 CALCULATION FORMULAS and worked-out problems showing their use. Also DRAWINGS of ELECTRICAL APPARATUS and DEVICES of which the inside connections are clearly shown. ALTERNATING CURRENT CALCULATIONS and dozens of everyday problems are covered. Recommended by

electrical men all over the country. Used in technical schools. Purchased by electrical concerns for employees and customers. There is no other book like it.

A \$1.00 bill brings the book. We refund your money if you are not fully satisfied.

Yorke Burgess, President

BURGESS ENGINEERING CO. Consulting Electrical Engineering

750 East Forty-Second Street, Chicago, Illinois



You benefit by mentioning the "Electrical Experimenter" when writing to advertisers.

(Continued from page 964)

Song Poems Wanted.

Write the Words for a Song. We write music and guarantee publisher's acceptance. Submit poems on war, love or any subject. Chester Music Co., 920 So. Michigan Ave., Room 265, Chicago, Ill.

Song-writers' Manual and Guide Sent Free! Contains valuable instructions and advice. Submit song-poems for examination. We will furnish music, copyright and facilitate publication or sale. Knickerbocker Studios, 319 Gaiety Bldg., New York.

You Write Words for a Song—We write the music, publish and secure a copyright. Submit poems on any subject. The Metropolitan Studios, 914 So. Michigan Ave., Room 113, Chicago, Ill.

Have you song poems? I have best proposition. Ray Hibbeler, D-115, 4040 Dickens Ave., Chicago.

Write the Words for a Song. We revise poems, write music and guarantee to secure publication. Submit poems on any subject. Broadway Studios, 197C Fitzgerald Bldg., New York.

Stamps and Coins.

Stamps—45 different packet hinges, 13 different Chile, 1 unused Trinidad—Tobago War Stamp. 13c. to applicants for approvals, others 16c. Reference. Baumann, 1033 Leveck St., Phila., Pa.

California gold; quarter size, 27c; half dollar size, 53c. Columbian nickel and catalogue, 10c. Norman Schultz, King City, Mo.

Stamps—61 All Different Free. Postage, 3c. Mention paper. Quaker Stamp Co., Toledo, O.

1,000 U. S. and Foreign Stamps, including Mexican Villa Dollar, all for 25c. C. W. Parker, 77 Kensington Heights, Meriden, Connecticut.

300 Different Stamps, 50c. Fred Anken, 630 79th St., Brooklyn, N. Y.

South America. Buy direct. 1,000 fine assorted Paraguay, Uruguay, etc., for \$2 bill. Exchange rare stamps with collectors and dealers; lots or on sheets. C. P. Mege, Necochea 193, Lomas De Zamora, Argentine Republic.

100 Different Stamps, 12c; 200, 27c. Michaels, 5600 Prairie, Chicago.

200 All Different Stamps, including Bosnia, Bavaria, China, Guatemala, Bulgaria, Bohemia, Poland, Turkey, etc., and Dime Stamp Album, only one to customer, all for 25c. Our approval sheets contain bargains priced at 1c. to 5c. net. 150 different U. S. postage and Civil War revenues for only 75c. Indiana Stamp Co., Dept. E., Indianapolis, Ind.

Best one cent approvals in America. F. P. Hand, 1117 So. 60th St., Phila., Pa.

Have you seen The Stamp Herald? Finest monthly stamp paper published. Subscription 50c. a year, 3 months' trial for 10c. Stamp Herald Publishing Co., Dept. E, Indianapolis, Ind.

Old Coins Wanted.

We Buy and Sell Old Coins. \$2 to \$500 each paid. Keep All Old Money; you may have valuable coins. Send 10c. for New Illustrated Coin Value Book, 4 x 6. Guaranteed prices. Get posted. Clarke Coin Co., Box 110, Le Roy, N. Y.

Cameras, Supplies—Photo Developing.

Mail us 15c. with any size film for development and six velvet prints. Or send six negatives any size and 15c. for six prints. Or send 25c. for one 8 x 10 mounted enlargement. Prompt, perfect service. Roanoke Photo Finishing Co., 255 Bell Ave., Roanoke, Va.

Amateurs! Send your next roll film and 15c. Will make six prints. Prompt, perfect service. Greenwood Studio, Woodbury, Vt.

Clean, Neat, Perfect Kodak Finishing at the lowest prices. Work returned the same day received. Send film for sample print and copy of catalogue on developing, printing, enlarging and hand coloring, also copy of Photo Craft Magazine, which will help you make better pictures. Photo Craft Co., Box 69, Ann Arbor, Mich.

Cameras. Lowest Prices. Supplies and Printing at reduced rates. Eliminate the middleman. Deal direct with us. Catalog free. Pearl Photo Place, 640 E. Clementine St., Philadelphia, Penna.

Chemicals.

Experimenters, are you interested in novel, chemical experiments? Send 10c. for large collection. Merel Sager, 44 Apple St., Tiffin, Ohio.

One Hundred Chemical Experiments printed in book form, 25c. Oliver R. Stalter, Oshawa, Ontario, Canada.

Chemicals, Chemicals, Chemicals. Regular \$5.00 chemical outfits \$3.50. Regular \$10.00 chemical outfits \$7.00. For a short time to get acquainted. Other prices on application. Eureka Specialty Co., Box 395, Central Station, Toledo, Ohio.

Crude Rubber—Experiment with pure uncompounded India Rubber. Make Tire Patching Cements, water proof cloth, porous tire filler, rubber stamps, etc. Pure para (highest grade India Rubber), 4 oz., 50c.; 8 oz., 80c.; 1 lb., \$1.25; 5 lbs., \$5.00. Shipped postpaid. Address Bunsen Supply House, 14 S. Canal St., Akron, Ohio.

Learn Dancing.

Learn Fox Trot, Waltz, Two-Step and One-Step in your own home by wonderful Peak System of Mail Instruction. Thousands taught successfully. No music needed. Write for free information. William Chandler Peak, M. D., Room 228, 821 Crescent Place, Chicago.

Electrical Supplies and Appliances.

Battery Charging pays big profits with HB Equipment. Electric Light Generators and Motors can also be furnished on easy payments. Full information free. Hobart Brothers, Troy, Ohio.

Lava Insulation is not molded but individually sawn, lathe turned, milled, drilled, threaded. No limitation on form, only on size. Killed at two thousand degrees. Hard, strong, accurate, fire, acid proof. Ask for book. American Lava Insulator Company, Chattanooga, Tenn.

Electrical and general scientific questions answered free. We desire the privilege of building any special wireless, electrical or scientific apparatus you may contemplate. Earl Cochran, Poplar Bluff, Mo.

Electrical Workers and all others who are interested in Electrical work in the reconstruction that is taking place to send us their name and receive descriptive literature of our modern blueprint chart method of electrical wiring. Souvenir information card included. Electrical Wiring Diagram Co., Box C 173, Altoona, Pa.

104 Induction motor connecting diagrams. Blueprints in book form. One, two, three phase, \$2.70. International Blueprint Co., Box 87, Gateway, Kansas City, Missouri.

Boys—Here is the simplest and cheapest electric telegraph ever devised. With the "K" Applicator you need no batteries. Get electricity free, instantly anywhere at any time. Send thirty cents (postal money order), for full instructions how to make the "K" Applicator and how to operate an electric telegraph without batteries. Is easier to make and requires less material than you would use in making a kite. Gives constant, smooth, even current day and night, never runs down even upon closed circuit. Works on any metallic line, even barbed wire fence, as no insulators necessary. The "K" Applicator. Missouri Valley, Ia.

Inventors: Models, Dies, Tools, 28 years' experience, work guaranteed, lowest price. Manufacturing of specialties our hobby. Peerless Die & Tool Co., 121 Opera Pl. D. B., Cincinnati, Ohio.

Radium Lokators guaranteed to shine in the dark. Attach to electric switches, gas jets, key holes, etc. 1,000 other uses. Send twenty-five cents. Agents 100% profit. Radium Products Co., 712 Monroe Place, West New York, New Jersey.

Storage Batteries. Make the plates yourself. We will tell you how. Sample plate 40c. Windsor Specialty Co., not incorporated. 5419 Windsor Ave., Chicago, Ill.

Boys, build your own Electric Motor. Complete outfit \$1.75. Blue Prints only 25c. A. F. Cassel, 52 W. 130th St., New York City.

Blueprints—Motor connections. 236 A. C. Single, two and three phase, including voltage, cycle, phase, speed changing. 123 D. C. diagrams. Shows voltage changing, testing, etc. 120 Transformer diagrams. Single, two and three phase. 170 Rheostats, controllers, compensators, automatic starters and voltage regulating devices, with both internal and external connections. 10 Samples A. C. 25c. Particulars free. Charles Chittenden, Dept. A, 3024 Matthews Avenue, Kansas City, Missouri.

For the Hair

I Was Bald. Obtained hair growth by an Indian's ointment containing genuine bear oil and rare plant juices. Many others have had wonderful results. Fine for dandruff. Harmless. Will send box, postpaid, with recipe, 10c. John Hart Brittain, 150 E. 32nd St., BB-300, New York.

Formulas.

Whiskey. I will not sell a million formulas for \$1.00. My little book of selected formulas will put you wise. Every formula has been carefully selected and plainly printed. Tells you how to make excellent Whiskey or Beer with a good Kick at small cost. A few good formulas are worth a million bad ones. Complete book and formulas \$1.00 bill. I'm prompt, too. Frank Ward, Box 503, Baltimore, Md., Dept. D.

Prohibition is here and I have lost my job. My recipes and formulas are yours for One Dollar. No still or alcohol required. Just ordinary kitchen utensils. Lee, 2314 E. Alhert, Phila.

500 Formulas, including Resilvering Mirrors, Renewing Dry Batteries, Mechanic Soap, Luminous Paint, 25c. Ideal Book Shop, 5501-EE North Robey, Chicago.

500 Successful money-making formulas and trade secrets. Postpaid, 25c. Charles Dynes, Winchester, Indiana.

1,000,000 Formulas. Processes. Trade secrets for every business. 1016 pages. \$2. Ideal Book Shop, 5501-EE North Robey, Chicago.

Printing.

150 Letter Heads, 150 Note Heads and 200 Envelopes, postpaid, \$2.00. Commercial Print, Wyoming, Delaware.

3000 Two-Color Labels, \$1.25. Irvin J. Wolf, Station E, Philadelphia.

Winter Fishing.

Julian's Liquid Fishing Lure. Whole winter's supply. One dollar. George Julian, Albany Bldg., Boston, Mass.

Wanted to Buy.

Cash for Old False Teeth—We pay up to \$35.00 per set (broken or not). Also buy discarded gold, jewelry, gold crowns, bridges, platinum, diamonds, watches and silver. Send now. Cash by return mail. Package held 5 to 10 days for sender's approval of our offer. U. S. Smelting Works, Dept. 73, Chicago, Ill.

Salesmen Wanted.

Salesman—Side or main line, to sell low priced 5,000-mile guaranteed tires. 30 x 3 1/2 non-skid sells for \$11.95; other sizes in proportion. Good money-making proposition for live wires. Write, Consolidated Tire Co., 616 So. Michigan, Chicago.

Stammering.

St-Stu-t-t-ering and Stammering cured at home. Instructive booklet free. Walter McDonnell, 105 Potomac Bank Bldg., Washington, D. C.

Song Writers.

Song Writers: You cannot afford to miss our proposition. Reference, any bank or first-class sheet music house. Warner C. Williams & Co., Dept. L, Indianapolis, Ind.

Short Stories, Manuscripts, Wanted.

Short Stories, Poems, Plays, etc., are wanted for publication. Literary Bureau, 165, Hannibal, Mo.

Scenery For Hire.

Collapsible Scenery for all plays. Decorations. Amelia Grain, Philadelphia.

Tricks, Puzzles and Games

Tricks, Puzzles, Magical Apparatus, Plays, Stage Supplies, Mind-reading Acts, Sensational Escapes and Illusions. Free, large illustrated 1919 catalogue. Oaks Magical Co., Dept. 549, Oshkosh, Wis.

Magic—Card Tricks. Sensational escapes, jokes, novelties. Everything in the amusement line. Large illustrated catalogue of a thousand tricks free. Write today. Largest amusement goods manufacturers in the world. Heaney Magic Co., Desk 208, Berlin, Wis.

Illusions—Stage tricks with 500 illustrations. Catalogue, 15c. Small catalogue free. Hornmann Magic Company, 304 W. 34th St., New York.

Magic. Entertain at home. Tricks, puzzles, novelties. Big Catalogue A, 25c. Martinka & Co., Inc., Harry Houdini, President, 493 Sixth Avenue, New York City.

Telegraphy.

Telegraphy (both Morse and wireless) and Railway Accounting taught thoroughly and quickly. Big salaries now paid. Great opportunities. Oldest and Largest School—est. 45 years. Catalogue free. Dodges Institute, 7th St., Valparaiso, Ind.

Wireless.

K. W. transmitting set and cabinet receiver for sale. Send for photos. O. R. Wimpy, 616 W. Sixth St., Marion, Ind.

Danger—High Voltage. I am selling my sign business complete. Consists of one cut for signs, one small cut for advertising and 300 signs 7 1/4" x 11 1/4" with envelopes. \$25. Leonard Beck, 1298 Carroll St., Brooklyn, N. Y.

10-kilowatt second-hand Clark wireless transformer, sealed in case, first-class working condition; operates on 110 volts alternating current; gigantic bargain at \$55.00; cost \$500.00. Sidney S. Friedrich, 350 East Commerce Street, San Antonio, Texas.

Complete receiving sets \$7.00 and up. With 1000-ohm receiver, tested mineral, guaranteed. Bulletin for stamp. Jenkins, Room 2, 923 Purchase St., New Bedford, Mass.

While They Last. Heavy current telephone transmitters with lug ready to mount on your radiophone set. \$3.00. Act now. Modern Radio Equipment Co., Elizabeth, N. J.

The Audion. Its early history and development, Electron Theory and Trigger Action, compiled by a Chief Electrician Radio who was stationed at the Naval Radio School as Instructor for two years, written by an old amateur for the amateurs in words that they can understand. Also blue print diagrams for hook ups for receiving damped signals, using both air exhausted and gas bulbs. Receiving undamped signals and regenerative circuits. Two-step amplifier, using same (A) and (B) batteries for both steps. Wireless telephony with power bulb. Working blue prints on how to build a "One to One" transformer for use with Audion Amplifier. All for \$2.00. Address T. O. McKenzie, 104 Warburton Ave., Yonkers, N. Y.

Stranded aerial wire, seven strands of Number 22 pure copper. High tensile strength and 100% conductivity. Supply limited at this price. No C.O.D.'s. 7 cent per foot. \$9.00 per thousand. Lee A. Bates, 8 Moen St., Worcester, Mass.

Switch Points. Binding posts, switch levers, and small parts; send 2c for catalogue describing these and other goods. A. W. Bowman & Co., 23 Church St. (Harvard Square), Cambridge, Mass.

LEARN WIRELESS AT HOME

The Demand for Wireless Operators Far Exceeds the Supply

The New York Wireless Institute will make you an operator—AT HOME—in your spare time—quickly, easily and thoroughly. No previous training or experience required. Our Home Study Course has been prepared by Radio Experts. Experts able to impart their practical and technical knowledge to YOU in an *easy to understand* way. The graded lessons mailed you will prove so fascinating that you will be eager for the next one. The instruments furnished *free*, will make it as easy to learn the Code as it was to learn to talk. *All you will have to do, is to listen.*

Big Salaries

Wireless operators receive excellent salaries ranging from \$125 to \$200 a month and it is only a stepping stone to better positions. There is practically no limit to your earning power. Men who but yesterday were Wireless Operators are now holding positions as Radio Engineers, Radio Inspectors, Radio Salesmen at salaries up to \$5000 a year.

Travel the World Over

A Wireless Operator can visit all parts of the world and receive fine pay and maintenance at the same time. Do you prefer a steady position without travel? There are many opportunities at the numerous land stations or with the Commercial Wireless or with the Steamship Companies.

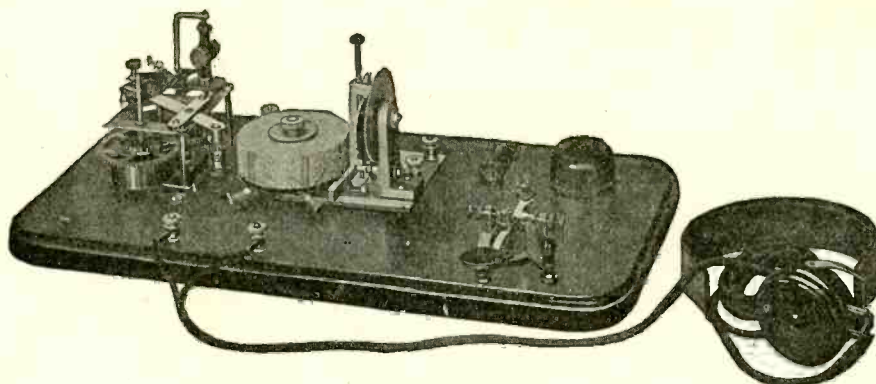

This wonderful Set for learning the Code furnished free with our Course

FREE Instruments and Text Books

We furnish free to all students, during the course, *the wonderful receiving and sending set exactly as produced in the illustration.* This set is not loaned, but given to all students completing the Course.

The Transmitter shown is the celebrated *Omnigraph* used by several Departments of the U. S. Government and by the leading Universities, Colleges, Technical and Telegraph Schools throughout the U. S. and Canada. Start the *Omnigraph*, place the phone to your ear and this remarkable invention will send you Wireless Messages, the same as though you were receiving them, through the air, from a Wireless Station hundreds of miles away. When you apply for your license, the U. S. Government will test you with the *Omnigraph*—the same model *Omnigraph* as we furnish to our students. Ask any U. S. Radio Inspector to verify this.

Easy Payments

A small payment down will enroll you. We will make the payments so easy that anyone ambitious to enter the fastest growing profession—Wireless—may do so.

Send for FREE Booklet

Without obligating you in any way, send for our booklet "How to Become an Expert Wireless Operator"—it is free. Mail the coupon below, or postal or letter—but do it today.

NEW YORK WIRELESS INSTITUTE

Dept. 51, 258 Broadway, New York City

New York Wireless Institute
Dept. 51, 258 B'way, N. Y. City

Send me free of charge, your booklet "How to Become an Expert Wireless Operator," containing full particulars of your Course, including your *Free Instrument Offer*.

Name

Address

City or Town.....State.....

FREE Post-Graduate Course

A one month's Post-Graduate Course, if you so desire, at one of the largest Wireless Schools in N. Y. City. New York—the Wonder City—the largest port in the World and the Headquarters of every leading Wireless and Steamship Company.

Health-Strength-Beauty Thru

Renulife VIOLET RAY

Treatments at Home

A recognized scientific effective means of handling your own case is afforded by the RENULIFE VIOLET RAY HIGH FREQUENCY GENERATOR. It is so designed and made that anyone can apply the wonderful corrective, upbuilding forces of the VIOLET RAY. This pleasant POWERFUL form of electricity has done and is doing wonders in relieving and eliminating pain and suffering. You owe it to yourself to investigate—find out the facts. Get our new booklet explaining the nature of the Violet Ray—its uses, benefits, and applications—send the coupon below at once.

WHAT USERS SAY

"The Renulife Violet Ray High Frequency Generator is superior in efficiency because of its perfect character and control of current, compactness and perfect insulation. The smallness and lightness of Electrode holder is also a great advantage." "The doctor told me that the trouble was hardening of the arteries. I would not be without it for all the money in the world." "I cannot recommend it too highly." "I have been using mine now for a week for Sciatica and I am highly pleased with results." "I think it is one of the best little machines that was ever invented." "I have used it with excellent results for the restoration of hair and stiff and sore rheumatic finger joints." "Am well pleased with the Generator, and the kind treatment received from your Company." "My Generator has stopped my neuritis." "Every house should have a Renulife Violet Ray High Frequency Generator for the treatment of Neuralgia; Neuritis; Sore Throat; Kernels in Neck; Cramps; Headache; Stiff Neck; Muscular Soreness; Rheumatism; Paralysis—in short, pain of all kinds."—M. D.

"I have been much relieved by the use of your Violet Ray Generator."

"It is fine for insomnia."

"I find it such a help in nervousness."

"I would not part with it for five times the price. It is sure a little wonder."

"I am more than pleased with the Generator, the whole family are using it."

THIS TYPE of Violet Ray instrument makes possible a light, convenient handle and permits large efficient units to be used contained in hand-some case.

OUR NEW BOOK

JUST OUT. This latest edition explains in detail, with many illustrations, the uses and benefits of Violet Ray. You should have one. Free for the asking.

SEND FOR BOOK!

COUPON FOR BOOK and Special Information

RENULIFE ELECTRIC CO.,
1201 Marquette Bldg., Detroit, Mich.

Please send without obligation, your book "Health," explaining Violet Ray treatments with Renulife Generators, also give full particulars as to its application for ailments checked below.

TREATS SUCCESSFULLY

- | | | |
|-----------------------------|-----------------------|-----------------------------------|
| ..Abscesses | ..Facial Neuralgia | ..Obesity |
| ..Anemia | ..Falling Hair | ..Pain in Abdomen |
| ..Asthma | ..Female Complaints | ..Paralysis |
| ..Arteriosclerosis | ..Goitre | ..Piles |
| ..Baldness | ..Gout | ..Pimples |
| ..Blackheads | ..Haemorrhoids | ..Psoriasis |
| ..Brain Fag | ..Hay Fever | ..Rheumatism |
| ..Bronchitis | ..Infantile Paralysis | ..Scars |
| ..Bunions | ..Insomnia | ..Sciatica |
| ..Bruises | ..Lanciness | ..Skin Diseases |
| ..Catarrh | ..Locomotor | ..Sore Throat and Throat Diseases |
| ..Colds | ..Lumbago | ..Spirals |
| ..Chilblains | ..Nervous Affections | ..Toothache |
| ..Dandruff | ..Neuralgia | ..Weak Eyes |
| ..Deafness and Ear Diseases | ..Neuritis | ..Warts and Moles |
| ..Eczema | | |
| ..Enlarged Prostate | | |

Name

Address

THOUSANDS OF VOLTS

No Shock—No Harm—Simply Great Benefits

Current from your light socket is transformed into the most powerful, effective purifying Health and Beauty giving agency; yet as painless and pleasant as a ray of sunshine. Made safe for use in any home, on infant or weakest invalid. Attacks the deep seated source of diseases, at the same time relieving the aches and pains which may be the annoying symptoms. Learn how this modern form of electricity—The Violet Ray—so acceptable to the human body actually saturates the whole system with invigorating life-laden forces, bringing back normal conditions. You may treat the local area but results are not confined to that part alone—the blood, nerves, tissues are revitalized, toned and restored.

Send for the Booklet—full of information—that tells the story so you can understand it.

Natures Own Aid

What is the strange relation between electricity and life? Some declare electricity is life. We do not know. But life cells do welcome and respond marvelously to electricity in the form of Violet Rays. It works with nature to restore where many other methods fail. It treats fundamentally and therefore is specified by physicians for a wide range of ailments—for rheumatism, neuritis, nerve and blood disorders—etc., etc.—both chronic and acute. See the list on coupon and ask for full particulars. Blood is brought to area treated—enriched and purified—assimilation and digestion improved—functions restored to normal. Combines the benefits of electricity, vibration, exercise, stimulation, and oxidation. Get the information as to what you may expect from the Violet Ray. Its astonishing low price places it within the reach of all. The Trial Plan proves its value, in actual use. Receive full information by return mail.

Renulife Electric Co., Inc.

1201 Marquette Building, Detroit, Mich.

Chicago Office, Room 410, 123 West Madison
CANADIAN RENULIFE ELECTRIC CO., LTD.

1201 Netting Building, Windsor, Ont.

Toronto Office, 614 C. P. R. Building

LOWEST PRICED

Efficient

VIOLET RAYS

Several Models for Home and Professional Use

High Class Sales Distributors Write for Proposition

OZONE Inhalations



Treat Your Own Face and Scalp as well as Specialists



Strengthens—Revitalizes—Builds up



Pain and Ache Eradicator—Without Equal



For Catarrh, Throat, Lungs—also Anemia